



Operation **Manual**

Goodrive350-19 Series VFD for Crane



SHENZHEN INVT ELECTRIC CO., LTD.

No.	Change description	Version	Release date
1	First release	V1.0	March 2020
2	<ul style="list-style-type: none"> • Added section 5.2.5 Switching from lifting in closed-loop vector control to open-loop vector control. • Added section 5.5 Tower crane rotating without vortex in space voltage vector control. • Added section 5.11 Brake. • Added section 5.12 Zero servo. • Added section 5.13 Anti-sway. • Added section 5.14.4 Master/slave switchover. • Changed group P29 to group P89. • Added groups P85, P86, and P94. • Added chapter 11 CW and SW module for port crane applications. • Added section A.5.6 CAN-NET two-in-one communication card (EC-TX511B). • Added the rope tracking function to group P91. • Added overspeed protection, stalling protection, and weighing functions to P92. • Updated P90.00 application macro. 	V1.1	April 2021
3	<ul style="list-style-type: none"> • Updated application macro parameters in sections 5.1, 5.2, 5.3, and 5.5. • Updated commissioning procedure descriptions in section 5.13. • Added section 5.14 Sway reducing. • Added section 5.5 Wind resistance • Added section 5.18.3 Using PTC • Added fault severity group parameters to group P11. • Added function codes about mapping of PZDs sent or received through PROFIBUS DP, CANopen, 	V1.2	March 2022

No.	Change description	Version	Release date
	<p>PROFINET, and EtherNet IP.</p> <ul style="list-style-type: none">• Added section A.5.6 EtherNet IP communication card.• Added section A.5.8 216 communication card and updated parameters in P87 accordingly.• Added section A.5.9 Modbus TCP communication card.• Added section A.7.1 4G communication card• Added section A.8.1 24V power supply card.		

Preface

Thank you for choosing Goodrive350-19 series variable-frequency drive (VFD) for cranes.

If not otherwise specified in this manual, the VFD always indicates Goodrive350-19 series VFD, which is a new generation of VFD that INVT develops for cranes by using advanced control technologies based on more than ten-year accumulative hoisting-industry experience. The VFD achieves excellent torque performance by integrating various special functions, including brake control, zero servo, quick stop, master/slave control, switchover between three sets of motor parameters, pre-magnetizing, light-load speed acceleration, anti-sway and sway reducing for the trolley and long travel, tower crane slewing without vortex, reverse braking, rope detection, and travel limit, to ensure the safety, reliability, and high efficiency of the machinery. The VFD can be widely used to drive the mechanisms such as about lifting, tilting, luffing, cross traveling, long traveling, slewing, and grabbing in hoisting machinery.

In order to meet diversified customer demands, the VFD provides abundant expansion cards including hoisting-oriented process card, PG card, communication card and I/O card to achieve various functions as needed. Each VFD can be installed with three expansion cards at most.

The PG card supports a variety of common encoders including incremental encoders and resolver-type encoders. In addition, it also supports pulse reference and frequency-division output. The PG card adopts digital filter technology to improve EMC performance and to realize stable transmission of the encoder signal over a long distance. It is equipped with the encoder disconnection detection function to contain the impact of system faults.

The VFD supports mainstream bus and control automation communication modes, including Modbus, CANopen, PROFIBUS-DP, PROFINET, and EtherCAT, and thus can be seamlessly interconnected with various hoist control systems. It can be connected to the Internet with wireless communication cards, by which you can monitor the VFD state anywhere any time through mobile APP.

The VFD uses high power density design. The VFD models in some power ranges carry built-in DC reactors and braking units to save installation space. Through overall EMC design, the VFD can satisfy the low noise and low electromagnetic interference requirements to cope with challenging grid, temperature, humidity and dust conditions, thus greatly improving product reliability.

This manual instructs you how to install, wire, set parameters for, diagnose and remove faults for, and maintain the VFD, and also lists related precautions. Before installing the VFD, read through this manual carefully to ensure the proper installation and running with the excellent performance and powerful functions into full play.

If the product is ultimately used for military affairs or weapon manufacture, comply with the export control regulations in the Foreign Trade Law of the People's Republic of China and complete related formalities.

The manual is subject to change without prior notice.

Contents

Preface	i
Contents.....	ii
1 Safety precautions.....	1
1.1 What this chapter contains	1
1.2 Safety definition	1
1.3 Warning	1
1.4 Safety guidelines.....	2
1.4.1 Delivery and installation	2
1.4.2 Commissioning and running.....	3
1.4.3 Maintenance and component replacement	4
1.4.4 Disposal.....	4
2 Quick startup.....	5
2.1 What this chapter contains	5
2.2 Unpacking inspection	5
2.3 Checking before use	5
2.4 Environment checking.....	5
2.5 Checking after installation	6
2.6 Basic commissioning.....	6
3 Product overview	7
3.1 What this chapter contains	7
3.2 Basic principles.....	7
3.3 Product specifications	9
3.4 Product nameplate	16
3.5 Model designation code	16
3.6 Product ratings.....	17
3.7 Structure	19
4 Installation guidelines	20
4.1 What this chapter contains	20
4.2 Mechanical installation	20
4.2.1 Installation environment	20
4.2.2 Installation direction	21
4.2.3 Installation method.....	22
4.2.4 Installing one VFD.....	23
4.2.5 Installing multiple VFDs.....	23
4.2.6 Vertical installation	24
4.2.7 Tilted installation	25
4.3 Standard wiring of the main circuit.....	26
4.3.1 Wiring diagram of the main circuit	26

4.3.2 Main circuit terminal diagram.....	27
4.3.3 Wiring procedure for main circuit terminals.....	31
4.4 Standard wiring of the control circuit.....	32
4.4.1 Wiring diagram of basic control circuit.....	32
4.4.2 Input/output signal connection diagram.....	34
4.4.3 Control circuit wiring of I/O expansion card 2.....	36
4.5 Wiring protection.....	37
4.5.1 Protecting the VFD and input power cable in case of short circuit.....	37
4.5.2 Protecting the motor and motor cable in case of short circuit.....	38
4.5.3 Protecting the motor against thermal overload.....	38
4.5.4 Bypass connection.....	38
5 Commissioning guidelines.....	39
5.1 Lifting in open-loop vector control.....	39
5.1.1 Wiring.....	39
5.1.2 Commissioning procedure.....	39
5.1.3 Macro parameters (P90.00=1).....	40
5.1.4 Points for attention.....	41
5.2 Lifting in closed-loop vector control.....	42
5.2.1 Wiring.....	42
5.2.2 Commissioning procedure.....	42
5.2.3 Macro parameters (P90.00=2).....	43
5.2.4 Points for attention.....	45
5.2.5 Switching from lifting in closed-loop vector control to open-loop vector control.....	46
5.2.6 Snail speed.....	46
5.3 Horizontal moving.....	47
5.3.1 Wiring.....	47
5.3.2 Commissioning procedure.....	47
5.3.3 Macro parameters (P90.00=3).....	47
5.3.4 Points for attention.....	48
5.4 Tower crane slewing with vortex.....	49
5.4.1 Wiring.....	49
5.4.2 Commissioning procedure.....	49
5.4.3 Macro parameters (P90.00=4).....	50
5.4.4 Points for attention.....	50
5.4.5 Controlling the vortex module through the HDO terminal.....	51
5.4.6 Controlling the vortex module through the AO terminal.....	52
5.5 Tower crane slewing without vortex in space voltage vector control.....	54
5.5.1 Wiring.....	54
5.5.2 Commissioning procedure.....	54
5.5.3 Macro parameters (P90.00=15).....	54

5.5.4 Points for attention	56
5.5.5 Wind resistance	56
5.6 Conical motor function.....	57
5.6.1 Wiring	57
5.6.2 Commissioning procedure.....	57
5.6.3 Macro parameters (P90.00=5).....	57
5.6.4 Points for attention	58
5.7 Lifting in space voltage vector control	59
5.7.1 Wiring	59
5.7.2 Commissioning procedure.....	59
5.7.3 Macro parameters (P90.00=9).....	60
5.7.4 Points for attention	61
5.8 Winching in closed-loop vector control (applicable to lifting in mineral wells and winches) ..	62
5.8.1 Wiring	62
5.8.2 Commissioning procedure.....	63
5.8.3 Macro parameters (P90.00=11)	63
5.8.4 Points for attention	66
5.8.5 How to use the -10+10V analog operating lever	66
5.9 Winching in open-loop vector control (applicable to lifting in mineral wells and winches)	67
5.9.1 Wiring	67
5.9.2 Commissioning procedure.....	68
5.9.3 Macro parameters (P90.00=12).....	68
5.9.4 Points for attention	70
5.10 Electric potentiometer.....	71
5.10.1 Wiring	71
5.10.2 Commissioning procedure.....	71
5.10.3 Electric potentiometer commissioning parameters	72
5.11 Brake	73
5.11.1 Brake function in space voltage vector control	73
5.11.2 Brake function in open/closed-loop vector control	77
5.11.3 Description about torque verification and brake slip	78
5.11.4 Commissioning parameters	80
5.11.5 Brake function in torque control	82
5.12 Zero servo.....	86
5.12.1 Zero servo function description.....	86
5.12.2 Zero servo function codes	89
5.13 Anti-sway	90
5.13.1 Commissioning procedure of anti-sway for tower cranes	90
5.13.2 Commissioning procedure of anti-sway for factory/port cranes (with one hook).....	92
5.13.3 Commissioning procedure of anti-sway for factory/port cranes (with two hooks)	92

5.13.4 Macro parameters	93
5.14 Sway reducing	96
5.14.1 Commissioning procedure	96
5.14.2 Macro parameters	97
5.15 Master/slave control	97
5.15.1 Function description	97
5.15.2 Terminal master/slave function	99
5.15.3 Master/slave communication	103
5.15.4 Master/slave switchover	109
5.15.5 User-defined application macros	112
5.16 Motor and macro switchover	117
5.16.1 Function description	117
5.16.2 Description about switching from motor 2 to motor 3	118
5.16.3 Motor and macro switchover parameters	118
5.16.4 Terminal-based motor and macro switchover flowchart	121
5.16.5 Shortcut multi-motor speed control mode switchover	121
5.17 Height measuring	123
5.17.1 Commissioning description	123
5.17.2 Parameters about height measuring	129
5.18 Temperature measuring	132
5.18.1 Using PT100/PT1000	132
5.18.2 Using KTY84	135
5.18.3 Using PTC	136
6 Basic operation guidelines	138
6.1 What this chapter contains	138
6.2 Keypad introduction	138
6.3 Keypad display	140
6.3.1 Displaying fault information	140
6.3.2 Editing function codes	140
6.4 Operation procedure	141
6.4.1 Modifying function codes	141
6.4.2 Setting a password for the VFD	142
6.4.3 Viewing VFD status	142
6.5 Basic operation description	143
6.5.1 What this section describes	143
6.5.2 Common commissioning procedure	143
6.5.3 Vector control	143
6.5.4 Space voltage vector control mode	143
6.5.5 Torque control	143
6.5.6 Motor parameters	143

6.5.7 Start/stop control.....	143
6.5.8 Frequency setting	143
6.5.9 Analog input.....	143
6.5.10 Analog output.....	143
6.5.11 Digital input	143
6.5.12 Digital output.....	143
6.5.13 Simple PLC.....	143
6.5.14 Multi-step speed running.....	143
6.5.15 Graded multi-step speed reference	145
6.5.16 Local encoder input.....	147
6.5.17 Commissioning procedures for position control and spindle positioning	147
6.5.18 Fault handling	147
7 Function parameter list.....	148
7.1 What this chapter contains	148
7.2 Function parameter list.....	148
P00 group—Basic functions	149
P01 group—Start and stop control.....	153
P02 group—Parameters of motor 1	160
P03 group—Vector control of motor 1	163
P04 group—V/F control	170
P05 group—Input terminals	179
P06 group—Output terminals	188
P07 group—Human-machine interface	194
P08 group—Enhanced functions	201
P09 group—PID control.....	210
P10 group—Simple PLC and multi-step speed control.....	215
P11 group—Protection parameters	219
P12 group—Parameters of motor 2	228
P13 group—SM control	231
P14 group—Serial communication.....	233
P15 group—Communication expansion card 1 functions	237
P16 group—Communication expansion card 2 functions	238
P17 group—Status viewing	241
P18 group—Status viewing in closed-loop control.....	246
P19 group—Expansion card status viewing	248
P20 group—Encoder of motor 1	250
P21 group—Position control	254
P22 group—Spindle positioning.....	262
P23 group—Vector control of motor 2.....	264
P24 group—Encoder of motor 2	267

P25 group—I/O card input functions	270
P26 group—I/O card output functions	274
P27 group—Programmable expansion card functions.....	275
P28 group—Master/slave control.....	278
P85 group—Anti-sway control	282
P86 group—Slewing control	284
P89 group—Parameters of motor 3	287
P90 group—Functions special for cranes.....	289
P91 group—Functions special for cranes.....	299
P92 group—Hoisting protection function group 3	313
P93 group—Closed-loop hoisting functions	323
P94 group—Hoisting status display	333
8 Troubleshooting.....	338
8.1 What this chapter contains	338
8.2 Indications of alarms and faults	338
8.3 Fault reset.....	338
8.4 Fault history	338
8.5 Faults and alarms	338
8.5.1 Faults and solutions	338
8.5.2 Alarms and solutions	349
8.5.3 Other status	351
8.6 Analysis on common faults	352
8.6.1 Motor fails to work	352
8.6.2 Motor vibrates	353
8.6.3 Overvoltage	354
8.6.4 Undervoltage	354
8.6.5 Motor overheating	355
8.6.6 VFD overheating.....	356
8.6.7 Motor stalls during ACC.....	357
8.6.8 Overcurrent.....	358
8.7 Countermeasures on common interference	358
8.7.1 Interference on meter switches and sensors.....	358
8.7.2 Interference on RS485 communication	359
8.7.3 Failure to stop and indicator shimmering due to motor cable coupling.....	360
8.7.4 Leakage current and interference on RCD.....	361
8.7.5 Live device chassis	362
9 Maintenance.....	363
9.1 What this chapter contains	363
9.2 Periodical inspection	363
9.3 Cooling fan.....	366

9.4 Capacitor	367
9.4.1 Capacitor reforming.....	367
9.4.2 Electrolytic capacitor replacement	368
9.5 Power cable.....	368
10 Communication protocol.....	369
10.1 What this chapter contains	369
10.2 Modbus protocol introduction.....	369
10.3 Application of Modbus	369
10.3.1 RS485	369
10.3.2 RTU.....	372
10.4 RTU command code and communication data.....	375
10.4.1 Command code 03H, reading N words (continuously up to 16 words).....	375
10.4.2 Command code 06H, writing a word.....	377
10.4.3 Command code 08H, diagnosis.....	378
10.4.4 Command code 10H, continuous writing	379
10.4.5 Data address definition.....	380
10.4.6 Fieldbus scale.....	384
10.4.7 Error message response	385
10.4.8 Read/Write operation examples.....	387
10.4.9 Common communication faults	391
11 CW and SW module for port crane applications.....	393
11.1 CWs for port crane applications	393
11.2 SWs for port crane applications	394
11.3 CANopen/PROFIBUS DP PZD communication.....	394
11.4 PROFINET/EtherNet IP PZD communication.....	400
Appendix A Expansion card.....	404
A.1 Model definition	404
A.2 Dimensions and installation	412
A.3 Wiring.....	414
A.4 I/O expansion card 1 (EC-IO501-00).....	415
A.5 Communication cards	417
A.5.1 Bluetooth communication card (EC-TX501) and WIFI communication card (EC-TX502)	417
A.5.2 PROFIBUS-DP communication card (EC-TX503)	419
A.5.3 Ethernet communication card (EC-TX504).....	420
A.5.4 CANopen communication card (EC-TX505) and CAN master/slave control communication card (EC-TX511)	421
A.5.5 PROFINET communication card (EC-TX509).....	423
A.5.6 EtherNet/IP communication card (EC-TX510)	425
A.5.7 CAN-NET two-in-one communication card (EC-TX511B)	426

A.5.8 216 communication card (EC-TX513)	428
A.5.9 Modbus TCP communication card (EC-TX515)	429
A.6 PG cards	430
A.6.1 Sin/Cos PG card (EC-PG502).....	430
A.6.2 UVW incremental PG card (EC-PG503-05).....	433
A.6.3 Resolver PG card (EC-PG504-00)	435
A.6.4 Multi-function incremental PG card (EC-PG505-12)	437
A.6.5 Simplified incremental PG card (EC-PG507-12).....	441
A.6.6 24V simplified incremental PG card (EC-PG507-24)	443
A.7 IoT cards	447
A.7.1 4G card (EC-IC502-2).....	447
A.8 Power supply cards	448
A.8.1 24V power supply card (EC-PS501-24).....	448
Appendix B Technical data.....	449
B.1 What this chapter contains.....	449
B.2 Derated application.....	449
B.2.1 Capacity	449
B.2.2 Derating	449
B.3 Grid specifications	450
B.4 Motor connection data	450
B.5 Application standards.....	450
B.5.1 CE marking	451
B.5.2 EMC compliance declaration	451
B.6 EMC regulations	451
B.6.1 VFD category of C2	452
B.6.2 VFD category of C3	452
Appendix C Dimension drawings.....	453
C.1 What this chapter contains.....	453
C.2 LED keypad.....	453
C.2.1 Structure diagram	453
C.2.2 Keypad mounting bracket	453
C.3 LCD keypad	454
C.3.1 Structure diagram	454
C.3.2 Keypad mounting bracket	454
C.4 VFD structure	455
C.5 Dimensions of AC 3PH 380V (-15%)–440V (+10%)	456
C.5.1 Wall mounting dimensions	456
C.5.2 Flange installation dimensions	458
C.5.3 Floor installation dimensions.....	460
C.6 Dimensions of AC 3PH 520V (-15%)–690V (+10%)	461

C.6.1 Wall mounting dimensions	461
C.6.2 Flange installation dimensions	462
C.6.3 Floor installation dimensions	463
Appendix D Optional peripheral accessories	465
D.1 What this chapter contains	465
D.2 Wiring of peripheral accessories	465
D.3 LCD keypad	466
D.4 Power supply	467
D.5 Cable	467
D.5.1 Powe cable	467
D.5.2 Control cables	468
D.5.3 Recommended cable size	469
D.5.4 Cable arrangement	471
D.5.5 Insulation inspection	472
D.6 Breaker and electromagnetic contactor	472
D.7 Reactor	474
D.8 Filters	477
D.8.1 Filter model description	478
D.8.2 Filter model selection	478
D.9 Braking system	480
D.9.1 Braking component selection	480
D.9.2 Braking resistor cable selection	484
D.9.3 Braking resistor installation	484
D.10 Regenerative feedback unit	485
D.10.1 Installation wiring for regenerative feedback unit	485
D.10.2 Regenerative feedback unit model selection	485
Appendix E STO function description	487
E.1 STO function logic table	487
E.2 STO channel delay description	487
E.3 STO function installation checklist	488
Appendix F Further information	489
F.1 Product and service queries	489
F.2 Feedback on INVT VFD manuals	489
F.3 Documents on the Internet	489

1 Safety precautions

1.1 What this chapter contains

Read this manual carefully and follow all safety precautions before moving, installing, operating and servicing the product. Otherwise, equipment damage or physical injury or death may be caused.

We shall not be liable or responsible for any equipment damage or physical injury or death caused due to your or your customers' failure to follow the safety precautions.

1.2 Safety definition

Danger: Severe personal injury or even death can result if related requirements are not followed.













Warning: Personal injury or equipment damage can result if related requirements are not followed.

Note: Actions taken to ensure proper running.





Trained and qualified professionals: People operating the equipment must have received professional electrical and safety training and obtained the certificates, and must be familiar with all steps and requirements of equipment installing, commissioning, running and maintaining and capable to prevent any emergencies.

1.3 Warning

Warnings caution you about conditions that can result in severe injury or death and/or equipment damage and advice on how to prevent dangers. The following table lists the warning symbols in this manual.

Symbol	Name	Description	Abbreviation
 Danger	Danger	Severe personal injury or even death can result if related requirements are not followed.	
 Warning	Warning	Personal injury or equipment damage can result if related requirements are not followed.	
 Forbid	Electrostatic sensitive	The PCBA may be damaged if related requirements are not followed.	
 Hot	Note Hot sides	Do not touch. The VFD base may become hot.	
 5 min	Electric shock	As high voltage still presents in the bus capacitor after power off, wait for at least five minutes (or 15 min / 25 min, depending on the warning symbols on the machine) after power off to prevent electric shock.	 5 min
	Read manual	Read the operation manual before operating.	
Note	Note	Actions taken to ensure proper running.	Note

1.4 Safety guidelines

	<ul style="list-style-type: none"> ◇ Only trained and qualified professionals are allowed to carry out related operations. ◇ Do not perform wiring, inspection or component replacement when power supply is applied. Ensure all the input power supplies have been disconnected before wiring or inspection, and wait for at least the time designated on the VFD or until the DC bus voltage is less than 36V. The minimum waiting time is listed in the following. <table border="1" style="margin-left: auto; margin-right: auto;"> <thead> <tr> <th colspan="2">VFD model</th> <th>Minimum waiting time</th> </tr> </thead> <tbody> <tr> <td>380V</td> <td>1.5kW–110kW</td> <td>5 minutes</td> </tr> <tr> <td>380V</td> <td>132kW–315kW</td> <td>15 minutes</td> </tr> <tr> <td>380V</td> <td>>355kW</td> <td>25 minutes</td> </tr> <tr> <td>660V</td> <td>22kW–132kW</td> <td>5 minutes</td> </tr> <tr> <td>660V</td> <td>160kW–355kW</td> <td>15 minutes</td> </tr> <tr> <td>660V</td> <td>400kW–630kW</td> <td>25 minutes</td> </tr> </tbody> </table>	VFD model		Minimum waiting time	380V	1.5kW–110kW	5 minutes	380V	132kW–315kW	15 minutes	380V	>355kW	25 minutes	660V	22kW–132kW	5 minutes	660V	160kW–355kW	15 minutes	660V	400kW–630kW	25 minutes
VFD model		Minimum waiting time																				
380V	1.5kW–110kW	5 minutes																				
380V	132kW–315kW	15 minutes																				
380V	>355kW	25 minutes																				
660V	22kW–132kW	5 minutes																				
660V	160kW–355kW	15 minutes																				
660V	400kW–630kW	25 minutes																				
	<ul style="list-style-type: none"> ◇ Do not refit the VFD unless authorized; otherwise fire, electric shock or other injury may result. 																					
	<ul style="list-style-type: none"> ◇ The base may become hot when the machine is running. Do not touch. Otherwise, you may get burnt. 																					
	<ul style="list-style-type: none"> ◇ The electrical parts and components inside the VFD are electrostatic sensitive. Take measurements to prevent electrostatic discharge when performing related operations. 																					

1.4.1 Delivery and installation

	<ul style="list-style-type: none"> ◇ Do not install the VFD on inflammables. In addition, prevent the VFD from contacting or adhering to inflammables. ◇ Connect the optional braking parts (such as braking resistors, braking units or feedback units) according to the wiring diagrams. ◇ Do not run the VFD if it is damaged or incomplete. ◇ Do not contact the VFD with damp objects or body parts. Otherwise, electric shock may result.
---	---

Note:

- Select appropriate tools for VFD delivery and installation to ensure the safe and proper running and avoid physical injury or death. To ensure personal safety, take mechanical protective measures like wearing safety shoes and working uniforms.
- Protect the VFD against physical shock or vibration during the delivery and installation.
- Do not carry the VFD only by its front cover as the cover may fall off.
- The installation site must be away from children and other public places.

- Use the VFD in proper environments. (For details, see section 4.2.1 Installation environment.)
- Prevent the screws, cables and other conductive parts from falling into the VFD.
- As VFD leakage current caused during running may exceed 3.5mA, apply reliable grounding and ensure the ground resistance is less than 10Ω. The PE ground conductor and phase conductor have equal conductivity capability. For the models of 30kW and higher, the cross sectional area of the PE ground conductor can be slightly less than the recommended area.
- R, S and T are the power input terminals, and U, V and W are the output motor terminals. Connect the input power cables and motor cables properly; otherwise, damage to the VFD may occur.

1.4.2 Commissioning and running

	<ul style="list-style-type: none"> ◇ Cut off all power supplies connected to the VFD before terminal wiring, and wait for at least the time designated on the VFD after disconnecting the power supplies. ◇ High voltage presents inside the VFD during running. Do not carry out any operation on the VFD during running except for keypad setup. For 3PH AC 660V VFD models, the control terminals form extra-low voltage (ELV) circuits. Therefore, you need to prevent the control terminals from connecting to accessible terminals of other devices. ◇ The VFD may start up by itself when P01.21 is set to 1 (restart after power off). Do not get close to the VFD and motor. ◇ The VFD cannot be used as an "Emergency-stop device". ◇ The VFD cannot act as an emergency brake for the motor; it is a must to install a mechanical braking device. ◇ During driving a permanent magnet synchronous motor (SM), besides above-mentioned items, the following work must be done before installation and maintenance: <ol style="list-style-type: none"> a) All input power supplies have been disconnected, including the main power and control power. b) The permanent-magnet SM has been stopped, and the voltage on output end of the VFD is lower than 36V. c) After the permanent-magnet SM has stopped, wait for at least the time designated on the VFD, and ensure the voltage between + and - is lower than 36V. d) During operation, it is a must to ensure the permanent-magnet SM cannot run again by the action of external load; it is recommended to install an effective external braking device or cut off the direct electrical connection between the permanent-magnet SM and the VFD.
---	---

Note:

- Do not switch on or switch off the input power supplies of the VFD frequently.
- If the VFD has been stored without use for a long time, perform capacitor reforming (described in chapter 9 Maintenance), inspection and pilot run for the VFD before the reuse.
- Close the VFD front cover before running; otherwise, electric shock may occur.



1.4.3 Maintenance and component replacement

	<ul style="list-style-type: none"> ◇ Only trained and qualified professionals are allowed to perform maintenance, inspection, and component replacement for the VFD. ◇ Cut off all power supplies connected to the VFD before terminal wiring, and wait for at least the time designated on the VFD after disconnecting the power supplies. ◇ During maintenance and component replacement, take measures to prevent screws, cables and other conductive matters from falling into the internal of the VFD.
---	--

Note:

- Use proper torque to tighten screws. (For details, see D.5.3 Recommended cable size.)
- During maintenance and component replacement, keep the VFD and its parts and components away from combustible materials and ensure they have no combustible materials adhered.
- Do not carry out insulation voltage-endurance test on the VFD, or measure the control circuits of the VFD with a megohmmeter.
- During maintenance and component replacement, take proper anti-static measures on the VFD and its internal parts.

1.4.4 Disposal

	<ul style="list-style-type: none"> ◇ The VFD contains heavy metals. Dispose of a scrap VFD as industrial waste.
	<ul style="list-style-type: none"> ◇ Dispose of a scrap programmable controller separately at an appropriate collection point but not place it in the normal waste stream.

2 Quick startup

2.1 What this chapter contains

This chapter introduces the basic installation and commissioning rules that you need to follow to realize quick installation and commissioning.

2.2 Unpacking inspection

Check the following after receiving the product.

- | |
|--|
| ● Whether the packing box is damaged or dampened. If any problems are found, contact the local INVT dealer or office. |
| ● Whether the model identifier on the exterior surface of the packing box is consistent with the purchased model. |
| ● Whether the interior surface of the packing box is abnormal, for example, in wet condition, or whether the enclosure of the VFD is damaged or cracked. |
| ● Whether the VFD nameplate is consistent with the model identifier on the exterior surface of the packing box. |
| ● Whether the accessories (including the manual, keypad, and expansion card) inside the packing box are complete. |

If any problems are found, contact the local INVT dealer or office.

2.3 Checking before use

Check the following before using the VFD.

- | |
|---|
| ● Mechanical type of the load to be driven by the VFD to verify whether the VFD will be overloaded during work. Whether the power class of the VFD needs to be increased. |
| ● Whether the actual running current of the motor is less than the rated current of the VFD. |
| ● Whether the control accuracy required by the load is the same as that is provided by the VFD. |
| ● Whether the grid voltage is consistent with the rated voltage of the VFD. |
| ● Check whether expansion cards are needed for selected functions. |

2.4 Environment checking

Check the following before installing the VFD:

Note: When the VFD is built in a cabinet, the ambient temperature is the temperature of air in the cabinet.

- | |
|--|
| ● Whether the actual ambient temperature exceeds 40°C. When the temperature exceeds 40°C, derate 1% for every increase of 1°C. Do not use the VFD when the ambient temperature exceeds 50°C. |
| ● Whether the actual ambient temperature is lower than -10°C. If the temperature is lower than -10°C, use heating devices. |
| ● Whether the altitude of the application site exceeds 1000m. When the installation site altitude exceeds 1000 m, derate 1% for every increase of 100m. |

- | |
|--|
| <ul style="list-style-type: none"> ● Whether the actual environment humidity exceeds 90% or condensation occurs. If yes, take additional protective measures. |
| <ul style="list-style-type: none"> ● Whether there is direct sunlight or biological invasion in the environment where the VFD is to be used. If yes, take additional protective measures. |
| <ul style="list-style-type: none"> ● Whether there is dust or inflammable and explosive gas in the environment where the VFD is to be used. If yes, take additional protective measures. |

2.5 Checking after installation

Check the following after the VFD installation is complete.

- | |
|--|
| <ul style="list-style-type: none"> ● Whether the input power cables and motor cables meet the current-carrying capacity requirements of the actual load. |
| <ul style="list-style-type: none"> ● Whether correct accessories are selected for the VFD, the accessories are correctly and properly installed, and the installation cables meet the capacity carrying requirements of all components (including the reactor, input filter, output reactor, output filter, DC reactor, braking unit and braking resistor). |
| <ul style="list-style-type: none"> ● Whether the VFD is installed on non-flammable materials and the heat-radiating accessories (such as the reactor and braking resistor) are away from flammable materials. |
| <ul style="list-style-type: none"> ● Whether all control cables and power cables are run separately and Whether the routing complies with EMC requirement. |
| <ul style="list-style-type: none"> ● Whether all grounding systems are properly grounded according to the VFD requirements. |
| <ul style="list-style-type: none"> ● Whether all the installation clearances of the VFD meet the requirements in the manual. |
| <ul style="list-style-type: none"> ● Whether the installation mode conforms to the instructions in the operation manual. It is recommended that the VFD be installed uprightly. |
| <ul style="list-style-type: none"> ● Whether the external connection terminals of the VFD are tightly fastened and the torque is appropriate. |
| <ul style="list-style-type: none"> ● Whether there are screws, cables, or other conductive items left in the VFD. If yes, get them out. |

2.6 Basic commissioning

Complete the basic commissioning as follows before the actual use of the VFD:

- | |
|---|
| <ul style="list-style-type: none"> ● According to the actual motor parameters, select the motor type, set motor parameters, and select the VFD control mode. |
| <ul style="list-style-type: none"> ● Check whether autotuning is required. If possible, de-couple the VFD from the motor load to start dynamic parameter autotuning. If the VFD cannot be de-coupled from the load, perform static autotuning. |
| <ul style="list-style-type: none"> ● Adjust the ACC/DEC time according to the actual work condition of the load. |
| <ul style="list-style-type: none"> ● Perform commissioning by means of jogging and check whether the motor rotational direction is correct. If not, change the rotation direction by swapping any two motor phase wires. |
| <ul style="list-style-type: none"> ● Set all control parameters and then perform actual run. |

3 Product overview

3.1 What this chapter contains

This chapter mainly introduces the operation principles, product features, layouts, nameplates and model designation rules.

3.2 Basic principles

The VFD is used to control asynchronous AC induction motors and permanent-magnet synchronous motors. The following lists the main circuit diagrams of different VFD models. The rectifier converts 3PH AC voltage into DC voltage, and the capacitor bank of intermediate circuit stabilizes the DC voltage. The inverter converts DC voltage into AC voltage that can be used by an AC motor. When the circuit voltage exceeds the maximum limit value, external braking resistor will be connected to intermediate DC circuit to consume the feedback energy.

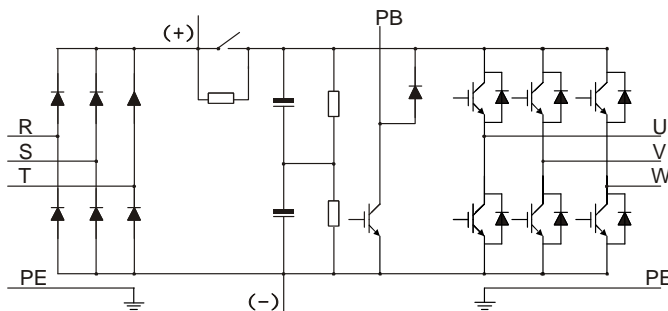

Figure 3-1 Main circuit diagram for 380V 15kW or lower VFD models

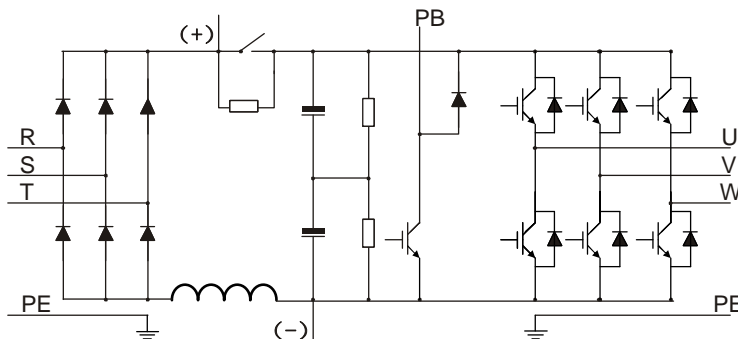

Figure 3-2 Main circuit diagram for 380V 18.5kW-110kW VFD models

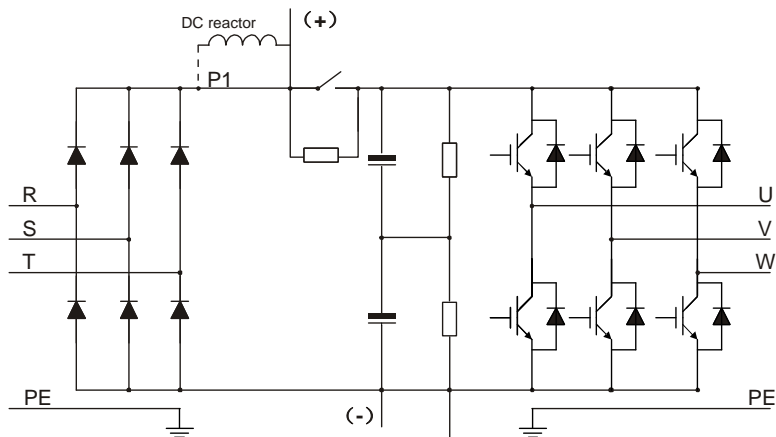

Figure 3-3 Main circuit diagram for 380V 132kW or higher VFD models

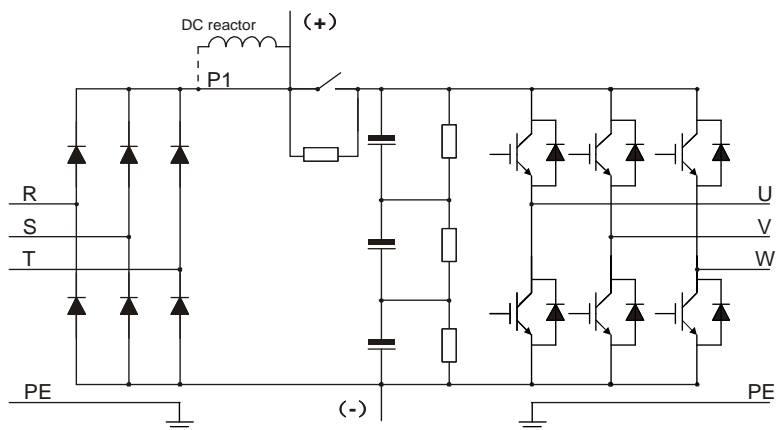

Figure 3-4 Main circuit diagram for 660V VFD models

Note:

- The 132kW and higher VFD models can be connected to external DC reactors. Before connection, remove the copper bar between P1 and (+). The 132kW and higher VFD models can be connected to external braking unit. DC reactors and braking units are optional parts.
- The 18.5kW–110kW (inclusive) VFD models are equipped with built-in DC reactors.
- The 110kW and lower VFD models carry built-in braking units. The models with built-in braking units can also be connected to external braking resistors. Braking resistors are optional parts.
- The 660V VFD models can be connected to external DC reactors. Before connection, remove the

copper bar between P1 and (+). These models can be connected to external braking unit. DC reactors and braking units are optional parts.

3.3 Product specifications

Table 3-1 Product specifications

Description		Specifications
Power input	Input voltage (V)	AC 3PH 380V (-15%)–440V(+10%); Rated voltage: 380V AC 3PH 520V (-15%)–690V(+10%); Rated voltage: 660V
	Input current (A)	See section 3.6 Product ratings.
	Input frequency (Hz)	50Hz or 60Hz; Allowed range: 47–63Hz
	Input power factor	30–110kW≥0.9
Power output	Output voltage (V)	0–Input voltage (V)
	Output current (A)	See section 3.6 Product ratings.
	Output power (kW)	See section 3.6 Product ratings.
	Output frequency (Hz)	0–150Hz
Technical control performance	Control mode	Space voltage vector control mode Sensorless vector control (SVC) mode Feedback vector control (FVC) mode
	Motor type	Asynchronous motor (AM) and permanent magnetic synchronous motor (SM)
	Speed ratio	1: 200 (SVC) 1: 1000 (FVC)
	Speed control accuracy	± 0.2% (SVC) ± 0.02% (FVC)
	Speed fluctuation	± 0.3% (SVC) ± 0.02% (FVC)
	Torque response	< 20ms (SVC) < 10ms (FVC)
	Torque control accuracy	10% (SVC) 5% (FVC)
	Starting torque	For AMs: 0.25Hz/150% (SVC) For SMs: 2.5Hz/150% (SVC) 0Hz/200% (FVC)
	Overload capacity	150% for 1 minute, 180% for 10 seconds, and 200% for 1 second
	Braking capability	100% for long time, 120% for 1 minute, and 160% for 10 seconds
Running control	Frequency setting method	Settings can be implemented through digital, analog, pulse frequency, multi-step speed running, simple PLC, PID,

Description		Specifications
performance		Modbus/Modbus TCP communication, PROFIBUS communication and so on. Settings can be combined and the setting channels can be switched.
	Automatic voltage regulation	The output voltage can be kept constant although the grid voltage changes.
	Fault protection	More than 30 protection functions, such as protection against overcurrent, overvoltage, undervoltage, overtemperature, phase loss, and overload.
Specialized functions	Braking protection	The 30–110 kW VFD models provide the function of protecting against braking resistor short connection, braking unit short connection, and PB-PE short connection.
	Brake control	Embedded with hoisting-oriented brake logic, and integrated with the torque verifying, brake feedback, zero position detection, restart after braking functions, which meet the industrial standards on the VFDs for cranes.
	Conical motor control	During startup, the magnetic flow is increased to release the brake. During stop, the magnetic flow is decreased to close the brake.
	Light load speed boost	In closed-loop mode, the speed can be boosted and limited at constant power status, and the speed is limited in stepped way. In open-loop mode, if the simplified speed boost way is used, the speed boosts to the set frequency in light load status; if the speed is boosted or limited in constant power status, the speed is limited in stepped way.
	Zero servo	In closed-loop mode, if the VFD detects load downward slip, the VFD automatically enters the zero servo state and outputs a brake failure alarm. When a level-2 fault occurs, if load downward slip occurs, the VFD automatically resets the fault, enters the zero servo state, and outputs a brake failure alarm.
	Anti-sway protection and sway reducing for the trolley and long travel	When the anti-sway protection function is enabled, the lifting mechanism needs to be configured with the encoder. Then the trolley and long-travel mechanism VFDs can obtain the height from the lifting VFD in real time since the lifting VFD communicates with the trolley and long-travel mechanism VFDs through AI or HDI connection or through the configured CAN master/slave control card. Then the given frequency and ACC/DEC time are output based on the embedded luffing and anti-sway algorithm. The trolley and long-travel mechanism

Description	Specifications
	<p>VFDs perform ACC/DEC run based on the startup/stop command and given reference. In this way, the stable state can be entered and swing disappears during stop.</p> <p>When the sway reducing function is enabled, there is no need to obtain the height. Then the mechanisms run according to the preset ACC/DEC time based on the embedded luffing and anti-sway algorithm and reduce variable frequency to enter the stable state or the swing at stop.</p>
Tower crane slewing without vortex	<p>Embedded curves for tower crane slewing without vortex help to adjust the ACC in real time so that the torque is steady, which can suppress arm rebound and vibration when the arm pauses or stops.</p>
Wind resistance for tower crane slewing	<p>The slewing speed cannot reach the given speed in a windy environment. Using the embedded wind resistance algorithm for tow crane slewing can overcome the impact of wind on slewing.</p>
Loose rope protection (only in closed-loop mode)	<p>Upward loose rope protection: If the speed limiting in loose rope state is detected, the speed limiting is canceled when timeout occurs or load is held.</p> <p>Downward loose rope protection: If the loose rope state is detected, the VFD reports a fault or alarm.</p>
Upward or downward position limit	<p>The function is used to limit the crane to run within the specified range. The VFD enables emergency stop and reports an alarm once the range is exceeded.</p>
Upward or downward DEC position	<p>When the deceleration signal is valid, the running speed of the crane is limited once the crane runs within the slow speed area.</p> <p>The function also features uni-directional speed limit. For example, only the upward running speed is limited when the crane runs within the upward slow speed area.</p>
Load position	<p>In closed-loop mode, an encoder is used to obtain load position information.</p>
Master/slave control	<p>Including power balance and speed synchronization between the master and slave.</p>
Hoisting application macro	<p>Including lifting, horizontal moving, construction elevator, and tower crane slewing, and user-defined application macros.</p>
Lifting and horizontal moving switchover	<p>Three groups of motor parameters, control modes, and application macros can be switched.</p>
Frequency	<p>When the bus voltage is continuously low, the reference</p>

Description	Specifications
decrease by voltage	frequency is decreased to keep the normal output torque of VFD.
Low voltage protection	When the bus voltage decreases transiently or the VFD quickly stops due to power outage, the function is used to ensure the hook does not slip. The low voltage protection function is automatically disabled once the bus voltage restores to the normal state.
Low-speed run protection	The VFD reports the low-speed run protection fault when the low-speed run time exceeds the allowed time. The prevents the axial cooling motor from being damaged due to overheating caused by long-time running.
Overload protection	In closed-loop mode, when overload occurs, upward lifting is restricted.
Vortex control	The HDO outputs PWM waves to directly control vortex.
Brake feedback	When the brake control signal is inconsistent with the brake feedback signal, the VFD handles the inconsistency according to the brake status to ensure safety.
Zero position detection	The zero position signal and running signal are mutually exclusive.
Torque verification	The VFD verifies the current or torque before brake release. The VFD performs brake release when the verification succeeds, and the VFD reports the verification fault when the verification fails.
One key open/closed loop switchover	The closed-loop control mode can be switched to the open-loop control mode through terminals. When the encoder is faulty, the open-loop control mode can be used. The switchover can get response only in stopped state but not in running state.
Jogging	After receiving a jogging command, the VFD can automatically start, run, and stop at the preset running frequency and time according to the settings. During the process, the brake can be normally opened or closed under the control of VFD, ensuring the stability without hook slip or exception when the crane starts or stops.
Smooth lifting	In high-speed lifting mode, the high speed is limited at the moment of steel rope straightening, reducing the impact caused by the sudden load to the crane at the lifting start.
Set frequency exception protection	If the set frequency is lower than the threshold after the brake is opened, the VFD reports the set frequency exception, which prevents slip caused by insufficient force at low speed.

Description		Specifications
	Motor overheat protection	The I/O expansion card can receive motor temperature sensor (PT100, PT1000 and PTC) input, but also AI can receive motor temperature sensor (PT100, PT1000 and KTY84) input, implementing motor overheat protection.
Peripheral interface	Terminal analog input resolution	No more than 20mV
	Terminal digital input resolution	No more than 2ms
	Analog input	2 inputs; AI1: 0–10V/0–20mA; AI2: -10–10V
	Analog output	1 input; AO1: 0–10V/0–20mA
	Digital input	Four regular inputs; max. frequency: 1kHz; internal impedance: 3.3kΩ Two high-speed inputs; max. frequency: 50kHz; supporting quadrature encoder input; with speed measurement function
	Digital output	One high-speed pulse output; max. frequency: 50kHz One Y terminal open collector output
	Relay output	Two programmable relay outputs RO1A: NO; RO1B: NC; RO1C: common RO2A: NO; RO2B: NC; RO2C: common Contact capacity: 3A/250VAC, 1A/30VDC
	Extended interfaces	Three extended interfaces: SLOT1, SLOT2, and SLOT3 Supporting PG cards, programmable expansion cards, communication cards, I/O cards and so on Note: 1. You can install optional expansion cards for 1.5–5.5kW VFD models and you are recommended to install them at slot 2. 2. I/O expansion card 2 has been installed at slot 3 for 7.5kW and higher VFD models as standard configuration.
I/O Expansion card 2	Relay output	Two programmable relay outputs. Contact capacity: 3A/250VAC, 1A/30VDC RO3A: NO; RO3C: common; RO4A: NO; RO4C: common
	Digital input	Three regular inputs Internal impedance: 6.6kΩ Max. input frequency: 1kHz Supporting the internal power 24V Supporting the voltage input of external power (-20%)24–48VDC(+10%) and (-10%)24–48VAC(+10%) Bidirectional input terminals, simultaneously supporting NPN and

Description		Specifications
		PNP connection methods One channel supports PTC input, while PTC acts at 2.5kΩ, and supports the input of only dry contacts sharing COM
	PT100 input	Independent PT100 and PT1000 input: 1. Resolution: 1°C
	PT1000 input	2. Range: -20°C–150°C 3. Detection precision: ±3°C 4. Supporting offline protection
Other	Installation method	Supports wall-mounting, floor-mounting and flange-mounting.
	Temperature of running environment	-10°C – 50°C; Derating is required if the ambient temperature exceeds 40°C.
	IP rating	IP20
	Pollution degree	Degree 2
	Cooling method	Forced air cooling
	DC reactor	Standard built-in part for 380V 18.5–110kW VFD models. Optional external part for 380V 132kW and higher models and for 660V models.
	Braking unit	Standard built-in part for 380V 110kW and lower VFD models. Optional external part for 660V models.
EMC filter	C3 filters are optional parts and can be built in the VFD. If a C3 filter is required, connect the jumper J10. After the C3 filter is configured, the VFD can meet IEC61800-3 C3 requirements. Optional external filters can be used to meet the IEC61800-3 C2 requirements.	

Table 3-2 Specialized functions

Function		Control mode		
Specialized functions	Mode	V/F	SVC	FVC
	Brake control in speed mode	√	√	√
	Restart after braking	√	√	√
	Brake feedback	√	√	√
	Zero position detection	√	√	√
	Current verification	√	√	√
	Torque verification		√	√
	Brake slip verification			√

Function		Control mode			
		Speed deviation detection	√	√	√
		Jogging	√	√	√
		Set frequency exception protection	√	√	√
		Brake control in torque mode		√	√
	Torque control	Torque control		√	√
		Pre torque		√	√
	Conical motor	Conical motor control	√		
	Light load speed boost	Simplified speed boost mode	√	√	√
		Constant power speed boost	√	√	√
		Constant power speed limit	√	√	√
		Stepped speed limit	√	√	√
	Safety functions	STO	√	√	√
		Zero servo			√
		Loose rope protection			√
		Stable lifting protection			√
		Upward or downward position limit	√	√	√
		Upward or downward DEC position limit	√	√	√
		Overload protection	√	√	√
		Braking short-circuit protection	√	√	√
		Motor disconnection protection	√	√	√
	Anti-snag protection			√	
	Master/slave control	Speed synchronization	√	√	√
		Power balance	√	√	√
		Position synchronization			√
	Slewing control	Vortex control	√		√
		Vortex removal control	√		√
		Reverse braking	√		√
		FWD/REV switchover	√		√
Wind resistance					
Jogging hook following		√		√	
Switchover control	Closed/open loop switchover	√	√	√	
	Motor parameter switchover	√	√	√	
	Simultaneous motor and master/slave switchover	√	√	√	
	Simultaneous motor and macro switchover	√	√	√	

Function		Control mode			
		Simultaneous motor and speed control mode switchover	√	√	√
	Other functions	Load position			√
		Height measuring			√
		Tower crane trolley rope tracking			
		Anti-sway protection and sway reducing for the trolley and long travel	√	√	√
		Motor temperature protection	√	√	√
		CVCF function	√		

3.4 Product nameplate

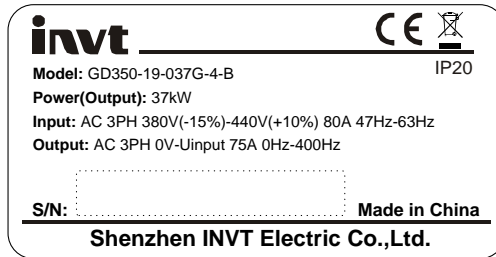

Figure 3-5 Product nameplate

Note: This is a nameplate example for standard Goodrive350-19 VFD models. The markings such as "CE" and "IP20" on the nameplate vary depending on actual certification status.

3.5 Model designation code

A model designation code contains product information. You can find the model designation code on the VFD nameplate and simplified nameplate.

GD350-19-037G-4-B

① ② ③ ④

Figure 3-6 Model description

Field	Description	Content
①	Product series abbreviation	GD350-19: Goodrive350-19 series VFD for cranes
②	Power range + Load type	037: 37kW G: Constant torque load
③	Voltage class	4: AC 3PH 380V (-15%)–440V (+10%) 6: AC 3PH 520V (-15%)–690V (+10%)
④	Built-in braking unit	B: Built-in braking unit

Field	Description	Content
		Empty: No built-in braking unit

3.6 Product ratings

Table 3-3 AC 3PH 380V (-15%)–440V(+10%)

VFD model	Output power (kW)	Input current (A)	Output current (A)
GD350-19-1R5G-4-B	1.5	5.0	3.7
GD350-19-2R2G-4-B	2.2	5.8	5
GD350-19-004G-4-B	4	13.5	9.5
GD350-19-5R5G-4-B	5.5	19.5	14
GD350-19-7R5G-4-B	7.5	25	18.5
GD350-19-011G-4-B	11	32	25
GD350-19-015G-4-B	15	40	32
GD350-19-018G-4-B	18.5	41	38
GD350-19-022G-4-B	22	48	45
GD350-19-030G-4-B	30	58	60
GD350-19-037G-4-B	37	72	75
GD350-19-045G-4-B	45	88	92
GD350-19-055G-4-B	55	106	115
GD350-19-075G-4-B	75	139	150
GD350-19-090G-4-B	90	168	180
GD350-19-110G-4-B	110	201	215
GD350-19-132G-4	132	265	260
GD350-19-160G-4	160	310	305
GD350-19-185G-4	185	345	340
GD350-19-200G-4	200	385	380
GD350-19-220G-4	220	430	425
GD350-19-250G-4	250	485	480
GD350-19-280G-4	280	545	530
GD350-19-315G-4	315	610	600
GD350-19-355G-4	355	625	650
GD350-19-400G-4	400	715	720
GD350-19-450G-4	450	840	820
GD350-19-500G-4	500	890	860

Note:

- The input current of the 1.5–500kW VFD models is measured in cases where the input voltage is 380V without additional reactors.

- The rated output current is the output current when the output voltage is 380V.
- Within the allowable input voltage range, the output current/power cannot exceed the rated output current/power.

Table 3-4 AC 3PH 520V (-15%)–690V (+10%)

VFD model	Output power (kW)	Input current (A)	Output current (A)
GD350-19-022G-6	22	35	27
GD350-19-030G-6	30	40	35
GD350-19-037G-6	37	47	45
GD350-19-045G-6	45	52	52
GD350-19-055G-6	55	65	62
GD350-19-075G-6	75	85	86
GD350-19-090G-6	90	95	98
GD350-19-110G-6	110	118	120
GD350-19-132G-6	132	145	150
GD350-19-160G-6	160	165	175
GD350-19-185G-6	185	190	200
GD350-19-200G-6	200	210	220
GD350-19-220G-6	220	230	240
GD350-19-250G-6	250	255	270
GD350-19-280G-6	280	286	300
GD350-19-315G-6	315	334	350
GD350-19-355G-6	355	360	380
GD350-19-400G-6	400	411	430
GD350-19-450G-6	450	445	465
GD350-19-500G-6	500	518	540
GD350-19-560G-6	560	578	600
GD350-19-630G-6	630	655	680

Note:

- The input current of the 22–350kW VFD models is measured in cases where the input voltage is 660V without DC reactors and input/output reactors.
- The input current of the 400–630kW VFD models is measured in cases where the input voltage is 660V and there are input reactors.
- The rated output current is the output current when the output voltage is 660V.
- Within the allowable input voltage range, the output current/power cannot exceed the rated output current/power.

3.7 Structure

The VFD structure is shown in the following figure (taking the 380V 30kW VFD model as an example).

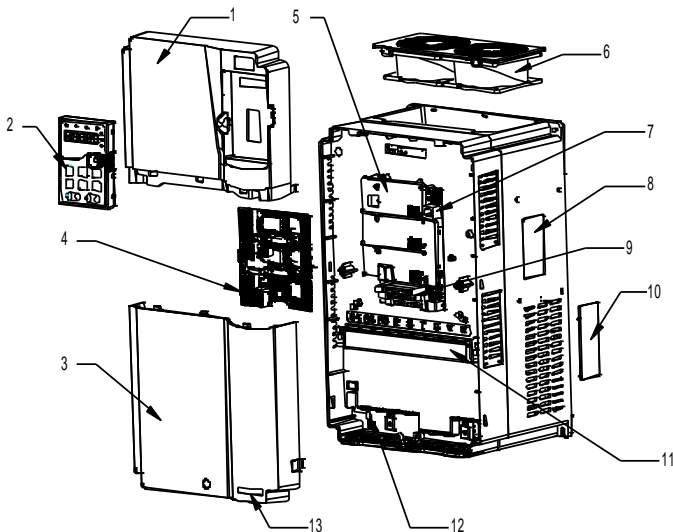



Figure 3-7 Structure diagram

No.	Name	Description
1	Upper cover	Protects internal components and parts.
2	Keypad	For details, see section 6.2 Keypad introduction.
3	Lower cover	Protects internal components and parts.
4	Expansion card	Optional. For details, see Appendix A Expansion card.
5	Baffle of control board	Protects the control board and install expansion card.
6	Cooling fan	For details, see chapter 9 Maintenance.
7	Keypad interface	Connects the keypad.
8	Nameplate	For details, see chapter 3 Product overview.
9	Control circuit terminals	For details, see chapter 4 Installation guidelines.
10	Cover plate of heat emission hole	Optional. Using the cover plate can enhance the IP rating, however, as this also increases internal temperature, and therefore derating is required.
11	Main circuit terminal	For details, see chapter 4 Installation guidelines.
12	POWER indicator	Power supply indicator
13	GD350-19 product series label	For details, see section 3.5 Model designation code

4 Installation guidelines

4.1 What this chapter contains

This chapter describes the mechanical installation and electrical installation of the VFD.

	<ul style="list-style-type: none"> ◇ Only trained and qualified professionals are allowed to carry out the operations mentioned in this chapter. Please carry out operations according to instructions presented in "Safety precautions". Ignoring these safety precautions may lead to physical injury or death, or device damage. ◇ Ensure the VFD power has been disconnected before installation. If the VFD has been powered on, disconnect the VFD power and wait for at least the time specified on the VFD, and ensure the POWER indicator is off. You are recommended to use a multimeter to check and ensure the VFD DC bus voltage is below 36V. ◇ The VFD installation must be designed and done according to applicable local laws and regulations. INVT does not assume any liability whatsoever for any VFD installation which breaches local laws or regulations. If recommendations given by INVT are not followed, the VFD may experience problems that the warranty does not cover.
---	---

4.2 Mechanical installation

4.2.1 Installation environment

The installation environment is essential for the VFD to operate with best performance in the long run. Install the VFD in an environment that meets the following requirements.

Environment	Condition
Installation site	Indoor
Ambient temperature	<ul style="list-style-type: none"> ◇ -10–50.0°C ◇ When the ambient temperature exceeds 40°C, derate 1% for every increase of 1°C. ◇ Do not use the VFD when the ambient temperature exceeds 50°C. ◇ In order to improve reliability, do not use the VFD in the places where the temperature changes rapidly. ◇ When the VFD is used in a closed space, such as control cabinet, use a cooling fan or air conditioner for cooling, preventing the internal temperature from exceeding the temperature required. ◇ When the temperature is too low, if you want to use the VFD that has been idled for a long time, install an external heating device before the use to eliminate the freeze inside the VFD. Otherwise, the VFD may be damaged.
Relative	◇ RH: less than 90%

Environment	Condition
humidity (RH)	<ul style="list-style-type: none"> ✧ Condensation is not allowed. ✧ The max. RH cannot exceed 60% in the environment where there are corrosive gases.
Storage temperature	-30–60.0°C
Running environment	<p>Install the VFD in a place:</p> <ul style="list-style-type: none"> ✧ Away from electromagnetic radiation sources ✧ Away from oil mist, corrosive gases, and combustible gases ✧ Without the chance for foreign objects such as metal powder, dust, oil and water to fall into the VFD (do not install the VFD onto combustible objects such as wood) ✧ Without radioactive substances and combustible objects ✧ Without hazard gases and liquids ✧ With low salt content ✧ Without direct sunlight
Altitude	<ul style="list-style-type: none"> ✧ Lower than 1000 meters ✧ When the altitude exceeds 1000m, derate by 1% for every increase of 100m. ✧ When the installation site altitude exceeds 3000m, consult the local INVT dealer or office.
Vibration	The max. amplitude of vibration cannot exceed 5.8m/s^2 (0.6g).
Installation direction	Install the VFD vertically to ensure good heat dissipation performance.

Note:

- The VFD must be installed in a clean and well-ventilated environment based on the housing IP rating.
- The cooling air must be clean enough and free from corrosive gases and conductive dust.

4.2.2 Installation direction

The VFD can be installed on the wall or in a cabinet.

The VFD must be installed vertically. Check the installation position according to following requirements. For details about the outline dimensions, see Appendix C Dimension drawings.

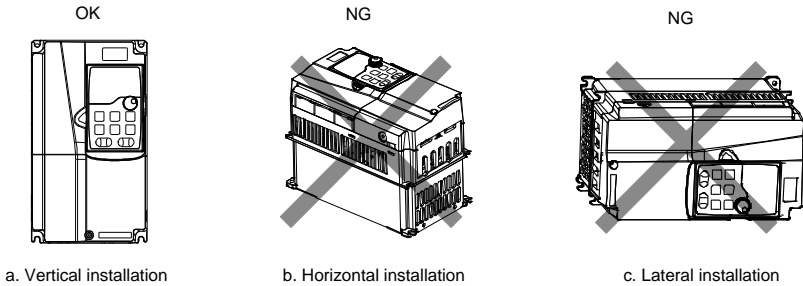

Figure 4-1 VFD installation direction

4.2.3 Installation method

There are three kinds of installation modes based on different VFD dimensions.

- Wall mounting: applicable to 380V 315kW and lower models, and 660V 355kW and lower models
- Flange mounting: applicable to 380V 200kW and lower models, and 660V 220kW and lower models
- Floor mounting: applicable to 380V 220–500kW and 660V 250–630kW models

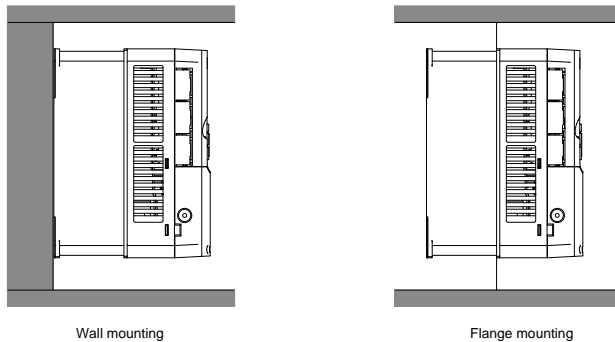

Figure 4-2 Installation mode

1. Mark the installation hole positions. For details about the installation hole positions, see Appendix C Dimension drawings.
2. Mount the screws or bolts onto the designated positions.
3. Lean the VFD against the wall.
4. Tighten the screws.

Note:

- When the flange mounting method is used, the (optional part) flange mounting plate is required

for the 380V 1.5–75kW VFD models but not required for the 380V 90–200kW and 660V 22–220kW VFD models.

- The 380V 220–315kW and 660V 250–355kW VFD models support the (optional part) installation base, which can house an input AC reactor (or DC reactor) and an output AC reactor.

4.2.4 Installing one VFD

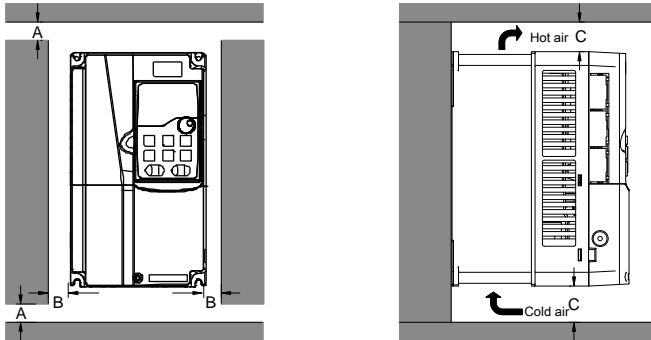

Figure 4-3 Installing one VFD

Note: For clearances B and C, each must be 100mm at least.

4.2.5 Installing multiple VFDs

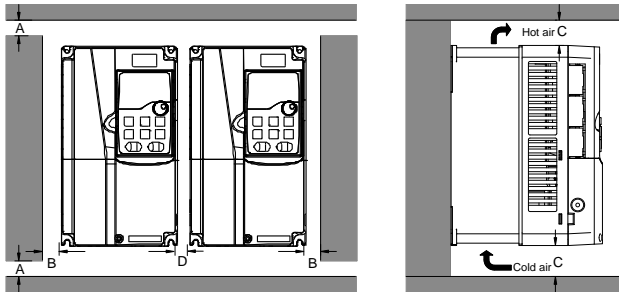

Figure 4-4 Parallel installation

Note:

- When you install VFDs in different sizes, align the top of each VFD before installation for the convenience of future maintenance.
- For clearances B, D, and C, each must be 100mm at least.

4.2.6 Vertical installation

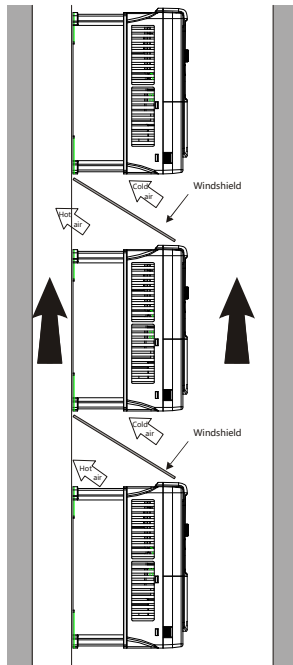

Figure 4-5 Vertical installation

Note: During vertical installation, you must install windshield, otherwise, the VFD will experience mutual interference, and the heat dissipation effect will be degraded.

4.2.7 Tilted installation

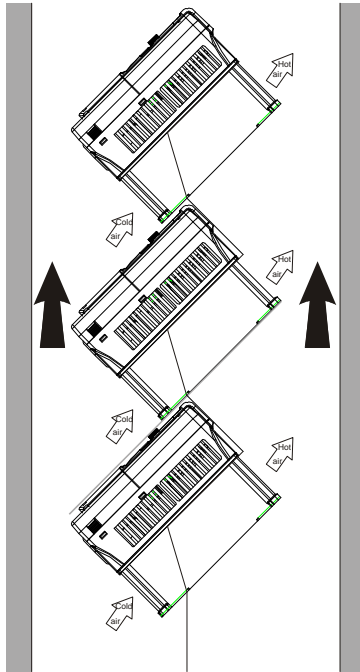

Figure 4-6 Tilted installation

Note: During tilted installation, it is a must to ensure the air inlet duct and air outlet duct are separated from each other to avoid mutual interference.

4.3 Standard wiring of the main circuit

4.3.1 Wiring diagram of the main circuit

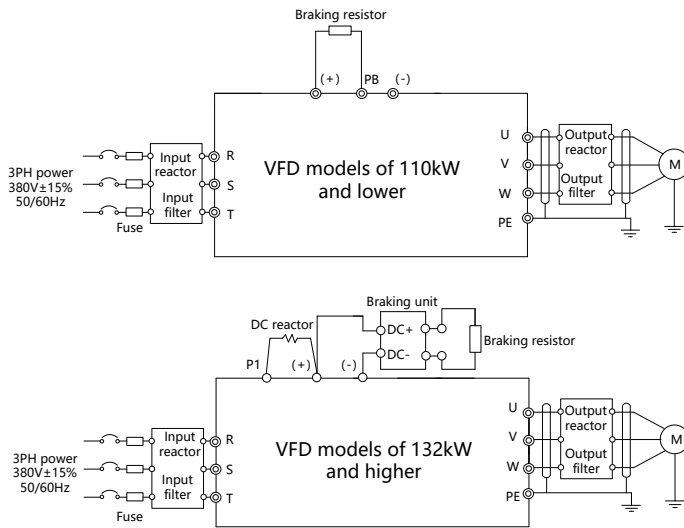

Figure 4-7 Main circuit wiring diagram for AC 3PH 380V(-15%)–440V(+10%)

Note:

- The fuse, DC reactor, braking unit, braking resistor, input reactor, input filter, output reactor and output filter are optional parts. For details, see Appendix D Optional peripheral accessories.
- P1 and (+) have been short connected by default for the 380V 132kW and higher VFD models. If you need to connect to an external DC reactor, remove the jumper between P1 and (+).
- Before connecting the braking resistor, remove the yellow warning label with PB, (+) and (-) from the terminal block; otherwise, poor contact may occur.

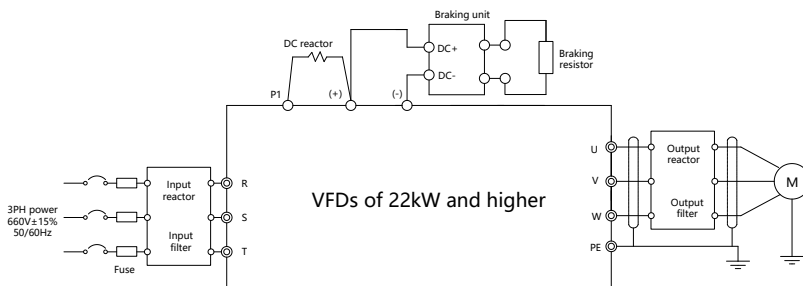

Figure 4-8 Main circuit wiring diagram for AC 3PH 520V(-15%)–690V(+10%)

Note:

- The fuse, DC reactor, braking resistor, input reactor, input filter, output reactor and output filter are optional parts. For details, see Appendix D Optional peripheral accessories.
- P1 and (+) have been short connected by default. If you need to connect to external DC reactor, remove the jumper between P1 and (+).
- Before connecting the braking resistor, remove the yellow warning label with (+) and (-) from the terminal block; otherwise, poor contact may occur.

4.3.2 Main circuit terminal diagram

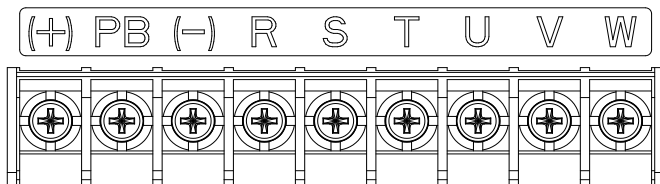

Figure 4-9 Main circuit terminal diagram for 3PH 380V 22kW and lower

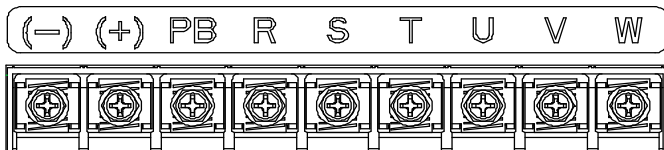

Figure 4-10 Main circuit terminal diagram for 3PH 380V 30-37kW

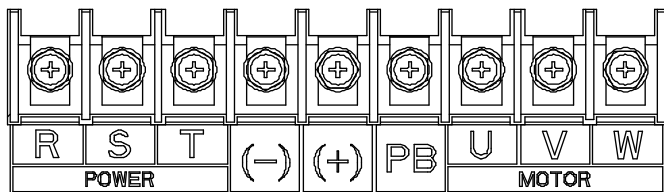

Figure 4-11 Main circuit terminal diagram for 3PH 380V 45-110kW

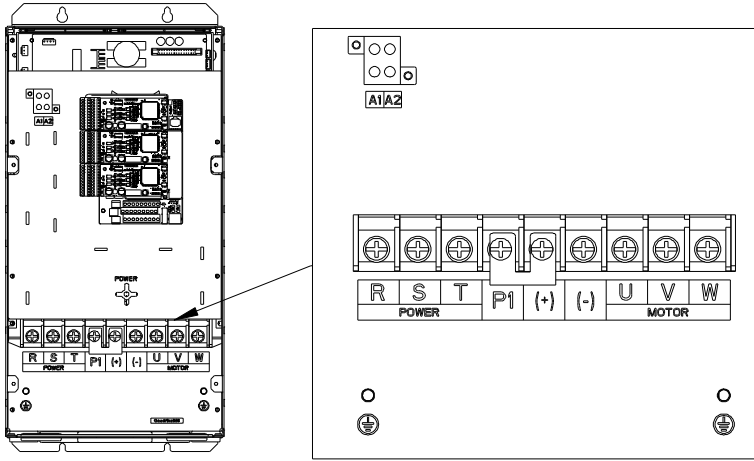

Figure 4-12 Main circuit terminal diagram for 660V 22-45kW

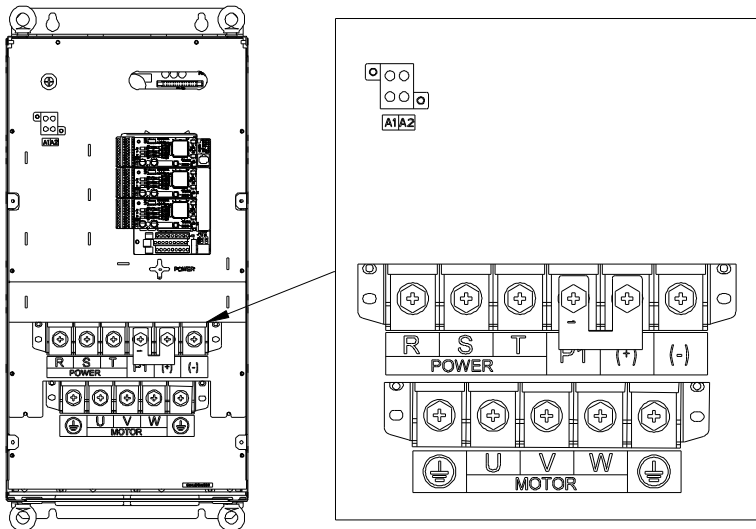

Figure 4-13 Main circuit terminal diagram for 660V 55-132kW

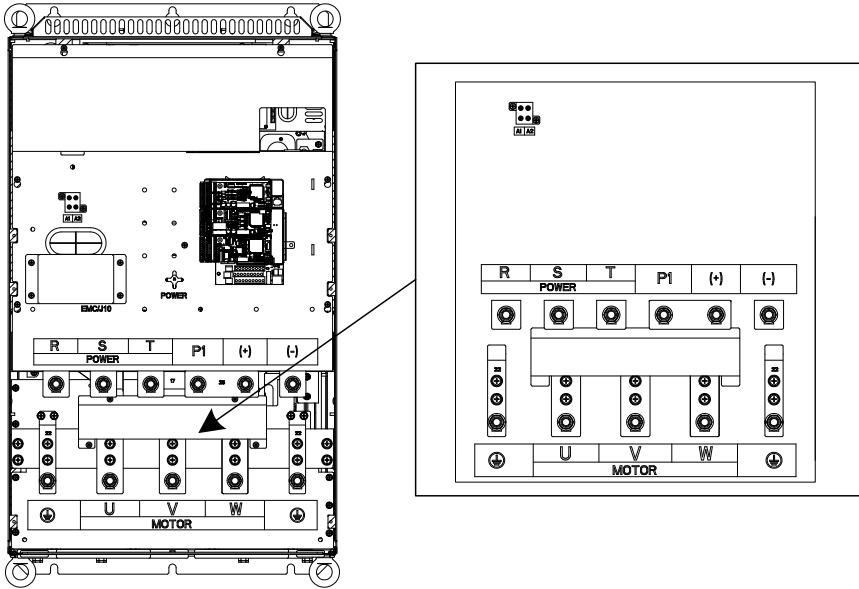

Figure 4-14 Main circuit terminal diagram for 380V 132–200kW (without A1 or A2) and 660V 160–220kW

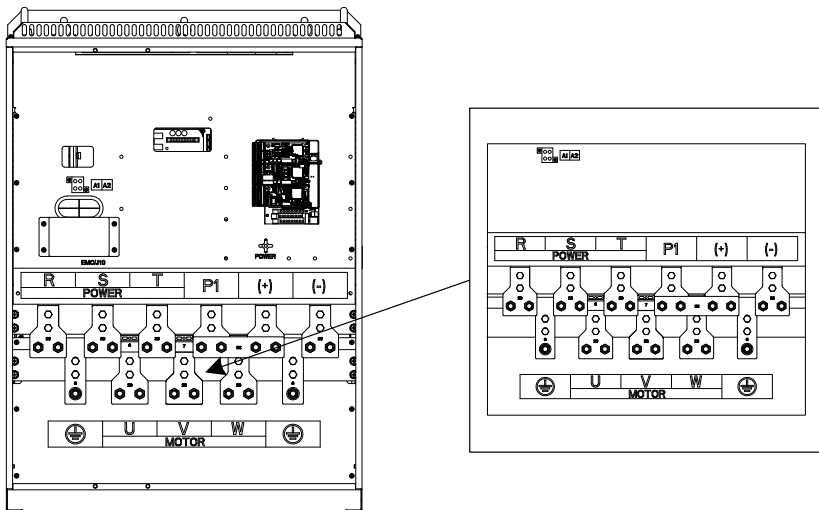

Figure 4-15 Main circuit terminal diagram for 380V 220–315kW (without A1 or A2) and 660V 250–355kW

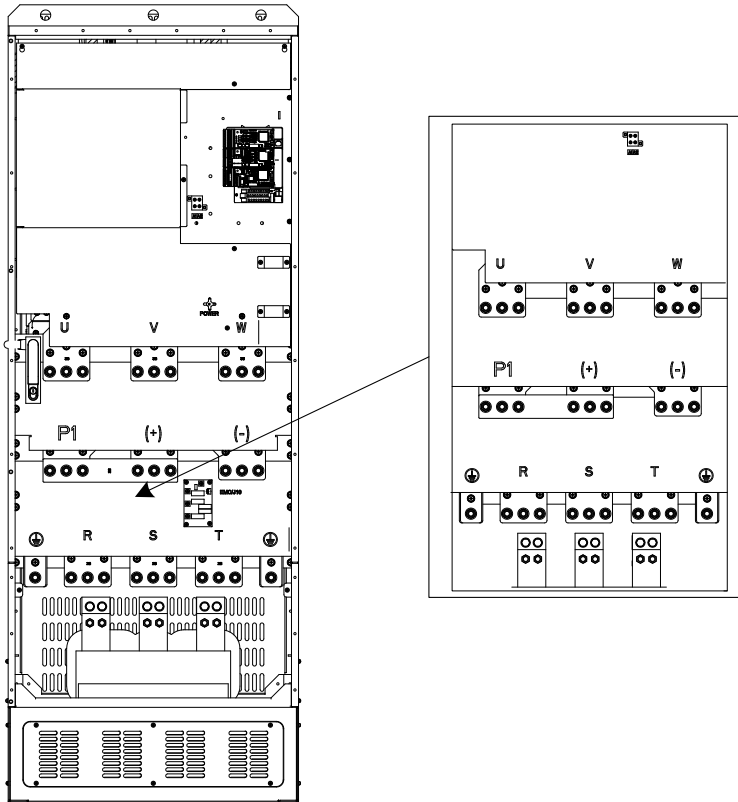

Figure 4-16 Main circuit terminal diagram for 380V 355–500kW (without A1 or A2) and 660V 400–630kW

Symbol	Terminal		Description
	380V 110kW and lower	380V 132kW and higher 660V series	
R, S, T	Main circuit power input		3PH AC input terminals, connecting to the grid
U, V, W	VFD outputs		3PH AC output terminals, which connect to the motor in most cases
P1	Not available	DC reactor terminal 1	P1 and (+) connect to external DC reactor terminals. (+) and (-) connect to the external
(+)	Braking resistor terminal 1	DC reactor terminal 2, Braking unit terminal 1	

Symbol	Terminal		Description
	380V 110kW and lower	380V 132kW and higher	
		660V series	
(-)	/	Braking unit terminal 2	braking unit.
PB	Braking resistor terminal 2	Not available	PB and (+) connect to the external braking resistor terminal.
PE	Safety protection grounding terminal (Grounding resistance less than 10 ohm)		Grounding terminal for safe protection. Each VFD must carry two PE terminals and proper grounding is required.
A1, A2	/	Available only for 660V	External 220V control power terminals

Note:

- Do not use asymmetrical motor cables. If there is a symmetrical grounding conductor in the motor cable besides the conductive shielded layer, ground the grounding conductor on the VFD end and motor end.
- Braking resistor, braking unit and DC reactor are optional parts.
- Route the motor cable, input power cable and control cable separately.
- "Not available" means this terminal is not for external connection.

4.3.3 Wiring procedure for main circuit terminals

1. Connect the grounding line of the input power cable to the grounding terminal (PE) of the VFD, and connect the 3PH input cable to R, S and T terminals and tighten up.
2. Connect the ground wire of the motor cable to the PE terminal of the VFD, connect the motor 3PH cable to the U, V and W terminals, and tighten up.
3. Connect optional parts such as the braking resistor that carries cables to designated positions.
4. Fasten all the cables outside the VFD mechanically if allowed.

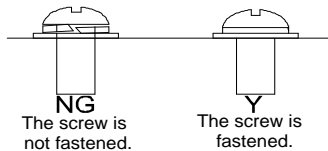

Figure 4-17 Screw installation diagram

4.4 Standard wiring of the control circuit

4.4.1 Wiring diagram of basic control circuit

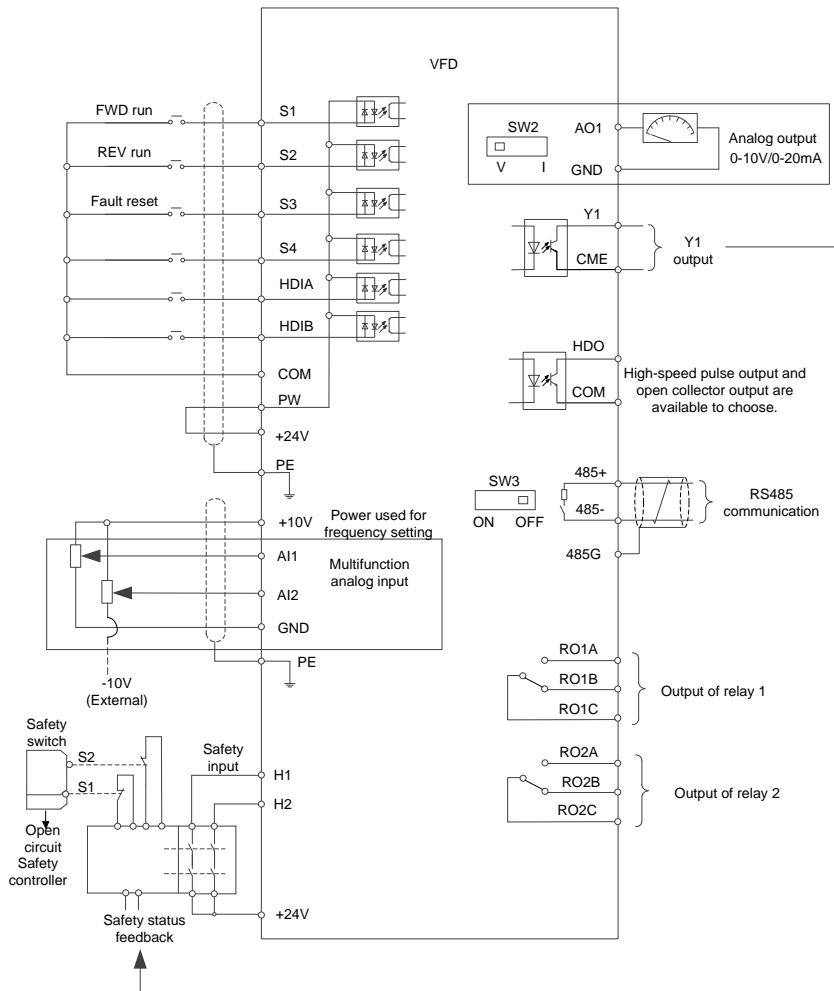

Figure 4-18 Wiring diagram of basic control circuit

Terminal	Description
+10V	Locally provided +10.5V power supply
AI1	Input range: For AI1, 0–10V or 0–20mA
AI2	For AI2, -10V – +10V Input impedance: 20kΩ for voltage input or 250Ω for current input

Terminal	Description	
	Whether voltage or current is used for input of AI1 is set through P05.50 Resolution: 5mV when 10V corresponds to 50Hz Deviation: $\pm 0.5\%$ at 25°C, when input is above 5V/10mA	
GND	Reference zero potential of +10.5V	
AO1	Output range: 0–10V or 0–20mA Whether voltage or current is used for output is set through the DIP switch SW2 Deviation: $\pm 0.5\%$ at 25°C, when output is above 5V/10mA	
RO1A	RO1 output; RO1A: NO; RO1B: NC; RO1C: common Contact capacity: 3A/AC250V, 1A/DC30V	
RO1B		
RO1C		
RO2A	RO2 output; RO2A: NO; RO2B: NC; RO2C: common Contact capacity: 3A/AC250V, 1A/DC30V	
RO2B		
RO2C		
HDO	Switch capacity: 200mA/30V Output frequency range: 0–50kHz Duty ratio: 50%	
COM	+24V common terminal	
CME	Common terminal of open collector output; short connected to COM by default	
Y1	Switch capacity: 200mA/30V Output frequency range: 0–1kHz	
485+	RS485 communication port, RS485 differential signal port and standard RS485 communication port must use twisted shielded pairs; the 120ohm terminal matching resistor for RS485 communication is connected through the DIP switch SW3.	
485-		
PE		
PW	Used to provide input digital working power from the external to the internal Voltage range: 12–30V	
+24V	User power supply provided by the VFD. Max. output current: 200mA	
S1	Digital input 1	<ul style="list-style-type: none"> Internal impedance: 3.3kΩ 12–30V voltage input is acceptable Bi-direction input terminal, supporting both NPN and PNP Max. input frequency: 1kHz All are programmable digital input terminals, the functions of which can be set through function codes
S2	Digital input 2	
S3	Digital input 3	
S4	Digital input 4	
HDIA	In addition to S1–S4 functions, the terminals can also act as high frequency pulse input channels.	
HDIB	Max. input frequency: 50kHz Duty ratio: 30%–70% Supporting quadrature encoder input; with the speed measurement function	

Terminal		Description
+24V—H1	STO input 1	<ul style="list-style-type: none"> • Safe torque off (STO) redundant input, connected to the external NC contact. When the contact opens, STO acts and the VFD stops output. • Safety input signal wires use shielded wires whose length is within 25m • The H1 and H2 terminals are short connected to +24V by default. Remove the short connectors from the terminals before using STO function.
+24V—H2	STO input 2	

4.4.2 Input/output signal connection diagram

You can select the NPN/PNP mode and internal/external power through the U-type short connector. NPN internal mode is adopted by default. NPN internal mode is adopted by default.

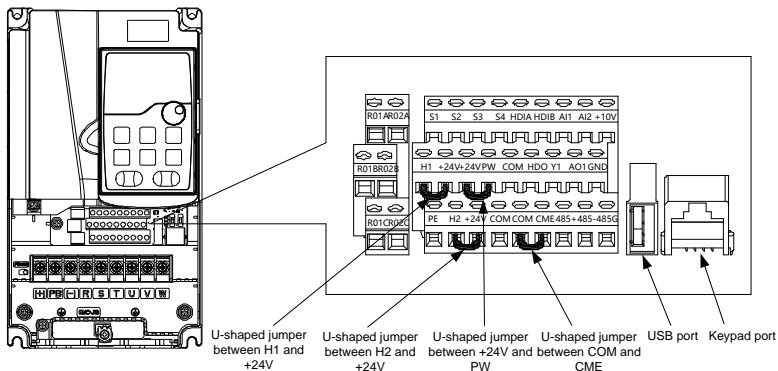

Figure 4-19 Position of U-type short connector

Note: As shown in the figure, the USB port can be used to upgrade the software, and the keypad port can be used to connect an external keypad. The external keypad cannot be used when the keypad of the VFD is used.

If input signal comes from NPN transistors, set the U-shaped jumper between +24V and PW based on the power used according to the following figure.

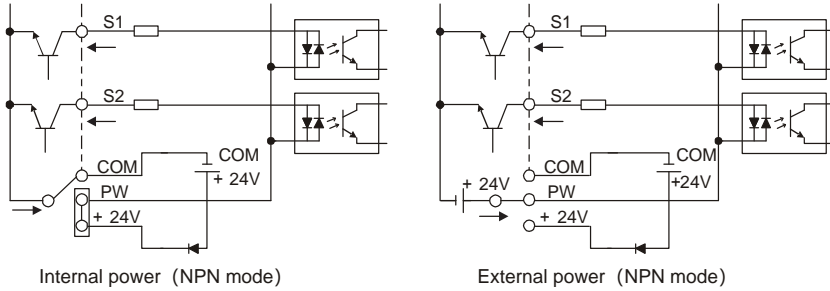

Figure 4-20 NPN mode

If input signal comes from PNP transistor, set the U-shaped jumper based on the power used according to the following figure.

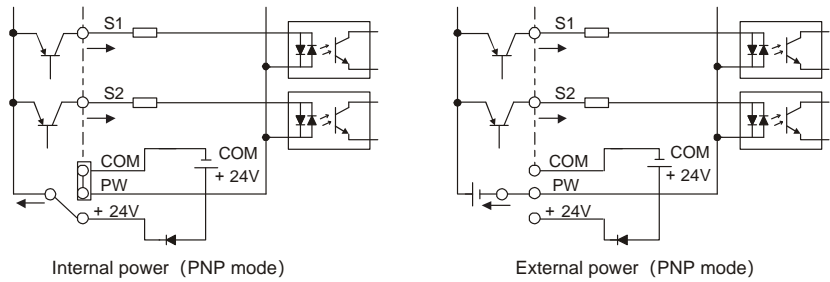

Figure 4-21 PNP mode

4.4.3 Control circuit wiring of I/O expansion card 2

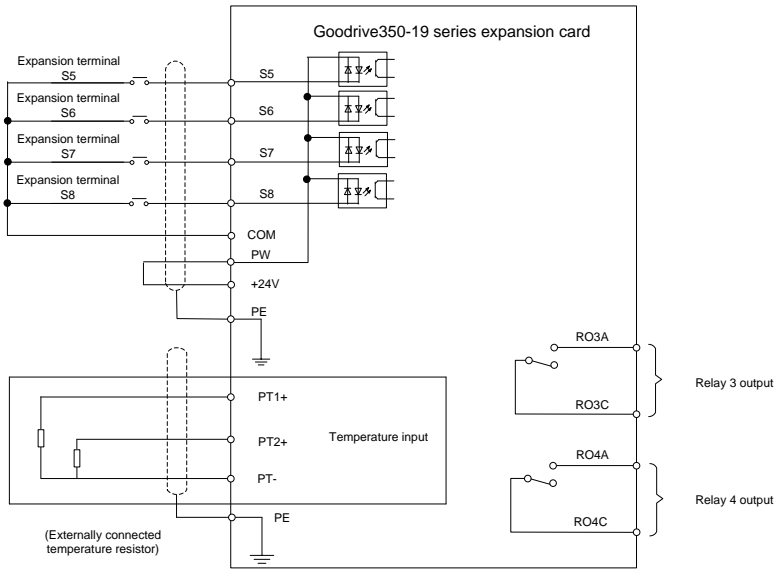

Figure 4-22 Control circuit wiring of I/O expansion card 2

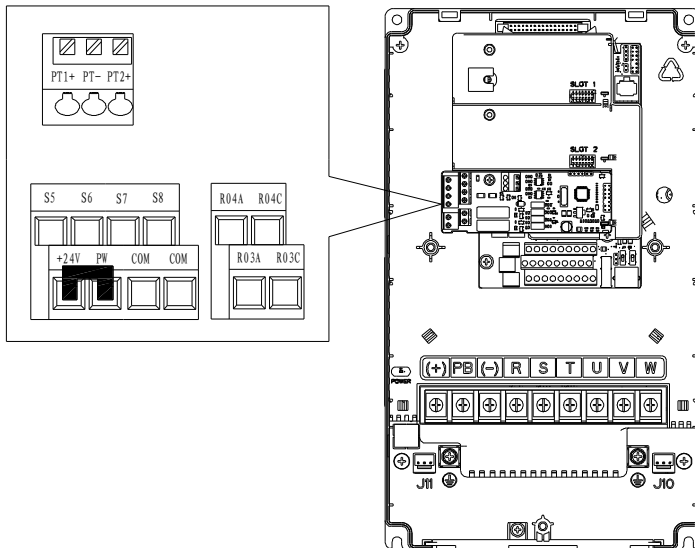

Figure 4-23 Terminal layout of I/O expansion card 2

Terminal	Description	
PT1+	Independent PT100 and PT1000 inputs: PT1+ connects to PT100 resistor, while PT2+ connects to PT1000 resistor.	
PT2+	<ul style="list-style-type: none"> Resolution: 1°C Range: -20°C–150°C Detection precision: 3°C Supporting offline protection 	
PT-	Reference zero potential of PT100/PT1000	
RO3A	RO3 outputs. RO3A: NO; RO3C: common	
RO3C	Contact capacity: 3A/AC250V, 1A/DC30V	
RO4A	RO4 outputs. RO4A: NO; RO4C: common	
RO4C	Contact capacity: 3A/AC250V, 1A/DC30V	
PW	Used to provide input digital working power from the external to the internal Voltage range: 24(-20%)–48VDC(+10%), 24(-10%)–48VAC(+10%) voltage input	
+24V	User power supply provided by the VFD. Max. output current: 200mA	
COM	+24V common terminal	
S5	Digital input 5	<ul style="list-style-type: none"> Internal impedance: 6.6kΩ Supporting the voltage input of external power (-20%)24–48VDC(+10%) and (-10%)24–48VAC(+10%) Supporting the internal power 24V Bi-direction input terminal, supporting both NPN and PNP Max. input frequency: 1kHz All are programmable digital input terminals, the functions of which can be set through function codes
S6	Digital input 6	
S7	Digital input 7	
S8	Digital input 8	

Note:

- You can install optional expansion cards for 1.5–5.5kW VFD models and you are recommended to install them at slot 2.
- I/O expansion card 2 has been installed at slot 3 for 7.5kW and higher VFD models as standard configuration.

4.5 Wiring protection**4.5.1 Protecting the VFD and input power cable in case of short circuit**

The VFD and input power cable can be protected in case of short circuit, avoiding thermal overload.

Carry out protective measures according to the following figure.

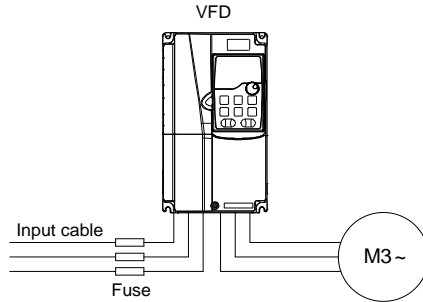



Figure 4-24 Fuse configuration

Note: Select the fuse according to the manual. In case of short circuit, the fuse protects input power cables to avoid damage to the VFD; if internal short-circuit occurs to the VFD, it can protect neighboring equipment from being damaged.

4.5.2 Protecting the motor and motor cable in case of short circuit

If the motor cable is selected based on VFD rated current, the VFD is able to protect the motor cable and motor during short circuit without other protective devices.

	<p>✧ If the VFD is connected to multiple motors, use a separated thermal overload switch or breaker to protect the cable and motor, which may require the fuse to cut off the short circuit current.</p>
---	--

4.5.3 Protecting the motor against thermal overload

The motor must be protected against thermal overload. Once overload is detected, current must be cut off. The VFD is equipped with the motor thermal overload protection function, which can block output and cut off the current (if necessary) to protect the motor.

4.5.4 Bypass connection

In some critical scenarios, the power/variable frequency conversion circuit needs to be configured to ensure proper operation of the system when a fault occurs to the VFD.

In some special scenarios, such as in soft startup, power-frequency running is directly performed after the startup, which requires bypass connection.

	<p>✧ Do not connect any power source to the VFD output terminals U, V, and W. The voltage applied to the motor cable may cause permanent damage to the VFD.</p>
---	---

If frequent switchover is needed, you can use the switch which carries mechanical interlock or a contactor to ensure motor terminals are not connected to input power cables and VFD output ends simultaneously.

5 Commissioning guidelines

5.1 Lifting in open-loop vector control

5.1.1 Wiring

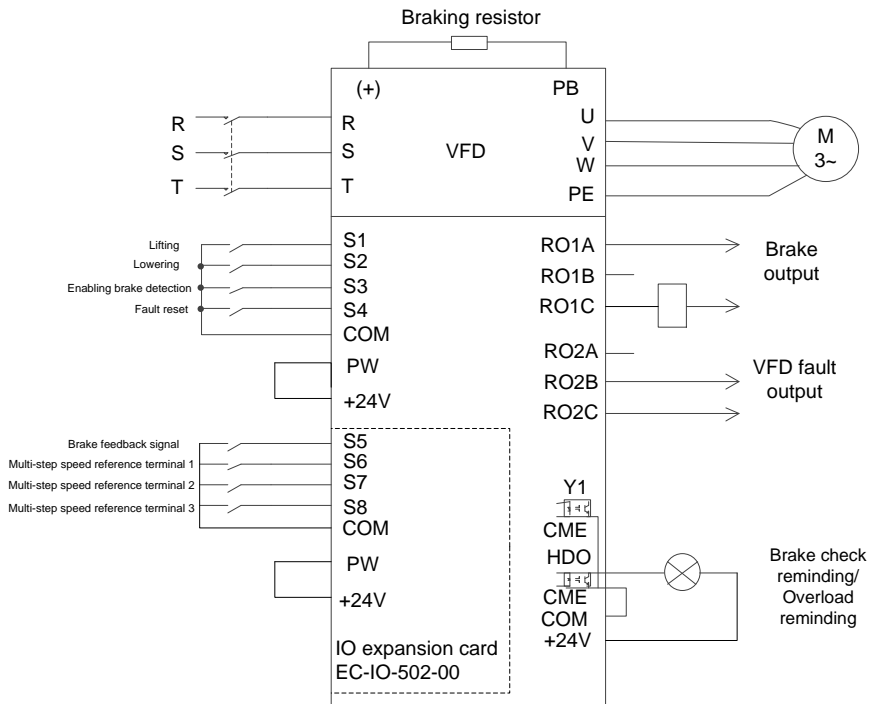

Figure 5-1 Wiring for lifting in open-loop vector control

Note: If the wiring is performed according to Figure 5-1, most VFD parameters need no adjustment. If the onsite function terminals are inconsistent with the terminals shown in the figure, adjust the input and output terminal functions according to the actual wiring after selecting this application macro.

5.1.2 Commissioning procedure

1. Check the wiring and ensure the wiring is proper.
2. Set P00.18=1 to restore to default settings.
3. Set motor parameters in P02.
4. Set P00.15=2. The keypad displays "-FUN-". Press the RUN key to perform static autotuning.
5. Set P90.00=1 to select the open-loop vector controlled lifting application macro.

6. Perform low-speed trial run.

5.1.3 Macro parameters (P90.00=1)

Function code	Name	Setting	Remarks
P00.00	Speed control mode	1	Sensorless vector control (SVC) mode 1
P00.01	Channel of running commands	1	Terminal
P00.03	Max. output frequency	100.00Hz	
P00.04	Upper limit of running frequency	100.00Hz	
P00.06	Setting channel of A frequency command	6	Multi-step speed run
P00.11	ACC time 1	6.0s	
P00.12	DEC time 1	4.0s	
P01.01	Starting frequency of direct start	1.00Hz	
P01.15	Stop speed	1.50 Hz	
P05.03	Function of S3	18	Multi-step speed terminal 3
P05.04	Function of S4	7	Fault reset
P06.03	RO1 output	49	Brake output
P10.04	Multi-step speed 1	8.0%	
P10.06	Multi-step speed 2	33.0%	
P10.08	Multi-step speed 3	50.0%	
P10.10	Multi-step speed 4	70.0%	
P10.12	Multi-step speed 5	90.0%	
P11.08	VFD/motor OL/UL pre-alarm selection	0x021	Enable underload protection to enhance equipment safety.
P11.11	Underload pre-alarm detection threshold	10%	
P11.14	Speed deviation detection value	20.0%	
P25.01	Function of S5	75	Brake feedback signal
P25.02	Function of S6	16	Multi-step speed 1
P25.03	Function of S7	17	Multi-step speed 2
P25.04	Function of S8	85	Brake detection
P25.10	Expansion card input terminal polarity	0x01	

Function code	Name	Setting	Remarks
P90.04	Enabling brake-oriented logic	1	The brake is controlled by the VFD.
P90.14	Forward brake release torque	40.0%	Corresponding to the motor rated torque
P90.15	Reverse brake release torque	30.0%	Corresponding to the motor rated torque
P90.19	Reverse brake closing frequency	3.50Hz	
P90.31	Enabling the monitoring on brake status	1	Enable the brake current monitoring (and brake feedback detection).
P91.08	Light load speed boost function selection	2	Constant power speed limit

Note: The macro parameter table does not contain some parameters that are factory default parameters.

5.1.4 Points for attention

1. If you only want to check whether the VFD runs properly, set P90.00=0 (Common mode). When you perform the test without connecting to a motor, to make the output frequency equal the set frequency, set P00.00=2 (Space voltage vector control mode).
2. If you perform empty-load commissioning, set P90.00 to 1 (Lifting in open-loop vector control), set P11.08 to 0x000 to disable underload protection, and set P90.14 and P90.15 to 0 to prevent the torque verification fault reporting caused by empty load. In addition, if no external braking resistor is connected, you need to increase the ACC/DEC time to prevent the bus overvoltage fault reporting caused by too fast stop.
3. If there is a brake feedback signal, set P25.01 to 75, and the macro has set this parameter by default. In addition, set P90.31 to 1. If there is no brake feedback signal, set P90.31 to 0 to prevent the misreporting of a brake feedback fault.
4. During onsite commissioning, if the VFD terminal signal upward/downward running command is inconsistent with the load lifting/lowering direction, adjust any two phase sequences of VFD output terminals U, V, and W.
5. If PLC control is used, speed signal and other input and output signal functions need to be adjusted according to the actual control logic.
6. This macro can meet the requirements of most lifting application cases, and the performance parameters have been optimized and do not need to be adjusted in most cases. If an exception occurs, see the function parameter chapter for adjustment or contact the technical support.

5.2 Lifting in closed-loop vector control

5.2.1 Wiring

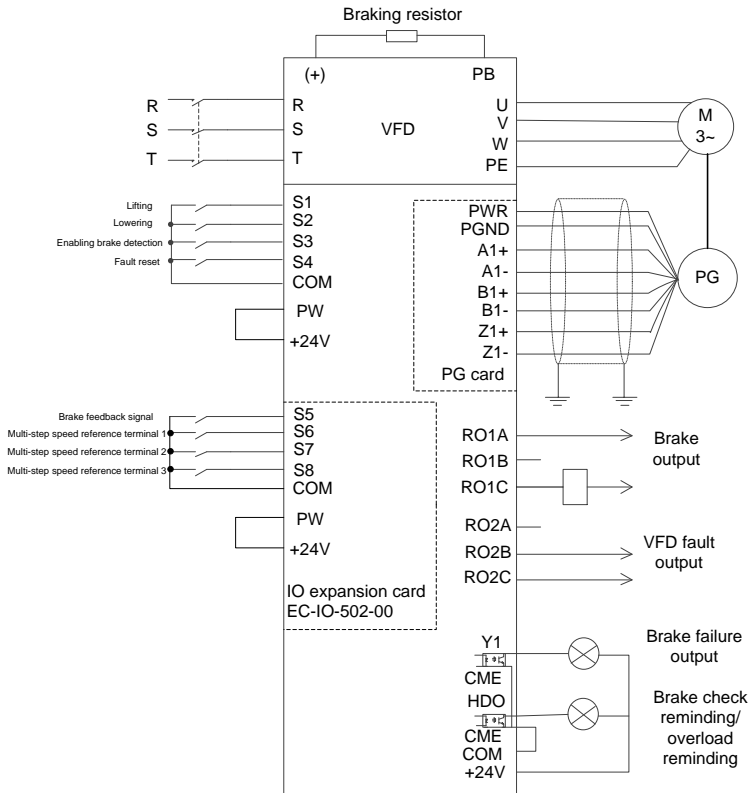

Figure 5-2 Wiring for lifting in closed-loop vector control

Note: If the wiring is performed according to Figure 5-2, most VFD parameters need no adjustment. If the onsite function terminals are inconsistent with the terminals shown in the figure, adjust the input and output terminal functions according to the actual wiring after selecting this application macro.

5.2.2 Commissioning procedure

1. Check the wiring and ensure the wiring is proper.
2. Set P00.18=1 to restore to default settings.
3. Set motor nameplate parameters in P02.
4. Set P00.15=2. The keypad displays "-FUN-". Press the RUN key to perform static autotuning.

5. Set P90.00=1, set the encoder type parameter P20.00, set the pulse per resolution (PPR) parameter P20.01. Perform low-speed upward running. Check the value of P18.00. If the value is negative, the encoder direction is reversed. Then you only need to set P20.02=0x001.
6. Set P90.00=2 to select the closed-loop vector controlled lifting application macro.
7. Perform low-speed trial run.

5.2.3 Macro parameters (P90.00=2)

Function code	Name	Setting	Remarks
P00.00	Speed control mode	3	Closed-loop vector control mode
P00.01	Channel of running commands	1	Terminal
P00.03	Max. output frequency	100.00Hz	
P00.04	Upper limit of running frequency	100.00Hz	
P00.06	Setting channel of A frequency command	6	Multi-step speed running
P00.11	ACC time 1	6.0s	
P00.12	DEC time 1	4.0s	
P01.01	Starting frequency of direct start	0.00Hz	
P01.15	Stop speed	0.20Hz	
P01.24	Stop speed delay	1.0s	
P03.00	Speed-loop proportional gain 1	30.0	
P03.01	Speed-loop integral time 1	0.100s	
P03.06	Speed loop output filter	1	
P03.10	Current-loop integral coefficient I	3500	
P05.03	Function of S3	18	Multi-step speed terminal 3
P05.04	Function of S4	7	Fault reset
P06.03	RO1 output	49	Brake output
P08.28	Auto fault reset count	1	
P10.02	Multi-step speed 0	3.0%	
P10.04	Multi-step speed 1	8.0%	
P10.06	Multi-step speed 2	33.0%	
P10.08	Multi-step speed 3	50.0%	
P10.10	Multi-step speed 4	70.0%	

Function code	Name	Setting	Remarks
P10.12	Multi-step speed 5	90.0%	
P10.14	Multi-step speed 6	0.6%	Slow speed at 0.6Hz
P10.16	Multi-step speed 7	2.0%	Slow speed at 2.0Hz
P11.08	VFD/motor OL/UL pre-alarm selection	0x021	Enable underload protection to enhance equipment safety.
P11.11	Underload pre-alarm detection threshold	1%	
P11.12	Underload pre-alarm detection time	1.00s	
P11.14	Speed deviation detection value	20.0%	
P23.15	PI separate setup for low-speed start/stop	1	Enable
P25.01	Function of S5	75	Brake feedback signal
P25.02	Function of S6	16	Multi-step speed 1
P25.03	Function of S7	17	Multi-step speed 2
P25.04	Function of S8	85	Brake detection
P25.10	Expansion card input terminal polarity	0x01	
P26.04	RO3 output	57	Brake failure alarm
P90.04	Enabling brake-oriented logic	1	The brake is controlled by the VFD.
P90.14	Forward brake release torque	30.0%	Corresponding to the motor rated torque
P90.15	Reverse brake release torque	20.0%	Corresponding to the motor rated torque
P90.16	Forward brake release frequency	0.40Hz	
P90.17	Reverse brake release frequency	0.40Hz	
P90.18	Forward brake closing frequency	0.20Hz	
P90.19	Reverse brake closing frequency	0.20Hz	
P90.20	Delay before forward brake release	0.100s	
P90.30	Torque verification fault	2.000s	

Function code	Name	Setting	Remarks
	detection time		
P90.31	Enabling the monitoring on brake status	1	Enable the brake current monitoring (and brake feedback detection).
P91.08	Light load speed boost function selection	3	Stepped speed limit
P91.18	Upward torque limit 1	65.0%	
P91.19	Upward restricted frequency 1	55.00Hz	
P91.20	Upward torque limit 2	40.0%	
P91.21	Upward restricted frequency 2	75.00Hz	
P91.26	Downward torque limit 1	50.0%	
P91.28	Downward torque limit 2	45.0%	
P91.29	Downward restricted frequency 2	70.00Hz	
P93.02	Zero servo protection mode	1	Zero servo input slows down.

Note: The macro parameter table does not contain some parameters that are factory default parameters.

5.2.4 Points for attention

1. If you only want to check whether the VFD runs properly, set P90.00=0 (Common mode).
2. If you perform empty-load commissioning, set P90.00 to 2 (Lifting in closed-loop vector control), set P11.08 to 0x000 to disable underload protection, and set P90.14 and P90.15 to 0 to prevent the torque verification fault reporting caused by empty load. In addition, if no external braking resistor is connected, you need to increase the ACC/DEC time to prevent the bus overvoltage fault reporting caused by too fast stop.
3. If there is a brake feedback signal, set P25.01 to 75, and the macro has set this parameter by default. In addition, set P90.31 to 1. Since the closed-loop mode is used, the brake current monitoring function is automatically enabled after the setting, and you can set P90.34 to set whether the reference speed is used if the brake status is incorrect. If there is no brake feedback signal, set P90.31 to 0 to prevent the misreporting of a brake feedback fault.
4. In closed-loop mode, brake slip verifying is enabled by default. If you need to check the running status of the VFD without a brake, set P93.01 to 0 to disable brake slip verifying.
5. During onsite commissioning, if the VFD terminal signal upward/downward running command is inconsistent with the load lifting/lowering direction, adjust any two phase sequences of VFD output terminals U, V, and W.

6. If PLC control is used, speed signal and other input and output signal functions need to be adjusted according to the actual control logic.
7. This macro can meet the requirements of most lifting application cases, and the performance parameters have been optimized and do not need to be adjusted in most cases. If an exception occurs, see the function parameter chapter for adjustment or contact the technical support.

5.2.5 Switching from lifting in closed-loop vector control to open-loop vector control

In closed-loop vector control mode, if an encoder exception occurs, you can switch to open-loop vector control by setting P90.03=5, the brake timing sequence of which is different from that of closed-loop vector control. To switch the application macro and motor control mode, do as follows:

1. Set P90.00=2 (Lifting in closed-loop vector control), and set P90.01=1 (Lifting in open-loop vector control).
2. Set P90.03=5 (Switch to SVC1 control).
3. Set S terminal function 62 to SVC1.
4. When the S terminal is invalid, the motor uses P90.00=2; when the S terminal is valid, the motor uses P90.01=1.

5.2.6 Snail speed

Certain operating consoles have the snail speed function. If you want to use the snail speed function, perform commissioning as follows:

1. Perform wiring according to the snail speed terminal description of the operating console.
2. Determine the multi-step speed corresponding to the snail speed function, and set the running frequency at this speed.

Note: The snail speed frequency must be higher than the brake release frequency.

5.3 Horizontal moving

5.3.1 Wiring

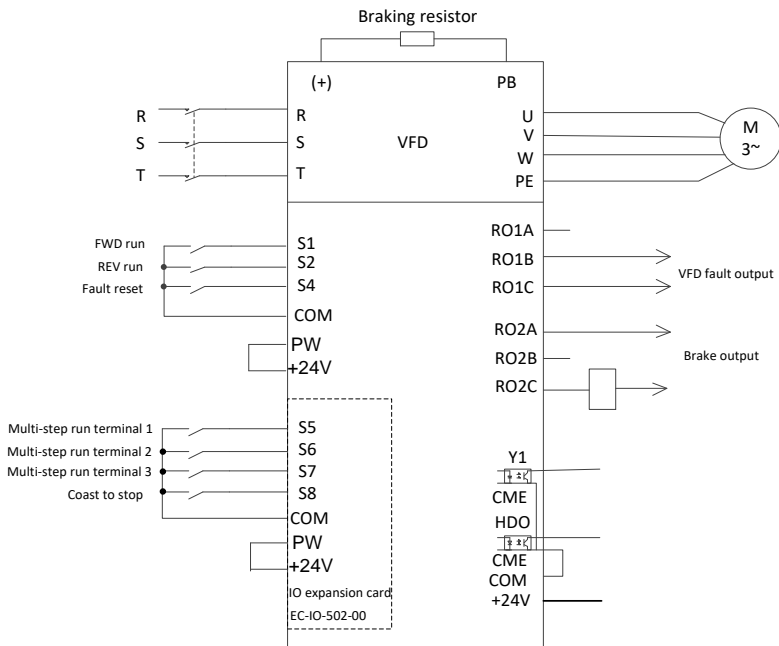

Figure 5-3 Wiring for horizontal moving

Note: If the wiring is performed according to Figure 5-3, most VFD parameters need no adjustment. If the onsite function terminals are inconsistent with the terminals shown in the figure, adjust the input and output terminal functions according to the actual wiring after selecting this application macro.

5.3.2 Commissioning procedure

1. Check the wiring and ensure the wiring is proper.
2. Set P00.18=1 to restore to default settings.
3. Set motor nameplate parameters in P02.
4. Set P90.00=3 to select the horizontal moving application macro.
5. Perform low-speed trial run.

5.3.3 Macro parameters (P90.00=3)

Function code	Name	Setting	Remarks
P00.01	Channel of running commands	1	Terminal

Function code	Name	Setting	Remarks
P00.03	Max. output frequency	100.00Hz	
P00.04	Upper limit of running frequency	60.00Hz	
P00.06	Setting channel of A frequency command	6	Multi-step speed running
P00.11	ACC time 1	5.0s	
P00.12	DEC time 1	4.0s	
P01.01	Starting frequency of direct start	2.00Hz	
P01.15	Stop speed	1.00 Hz	
P05.03	Function of S3	0	No function
P05.04	Function of S4	7	Fault reset
P06.03	RO1 output	5	VFD in fault
P06.04	RO2 output	1	Running
P10.04	Multi-step speed 1	8.0%	Corresponding to the max. frequency
P10.06	Multi-step speed 2	18.0%	Corresponding to the max. frequency
P10.08	Multi-step speed 3	32.0%	Corresponding to the max. frequency
P10.10	Multi-step speed 4	50.0%	Corresponding to the max. frequency
P11.05	Current limit mode	0x11	Enable software and hardware current limit.
P11.06	Automatic current limit threshold	160.0%	
P11.26	Enabling special functions	0x01	
P25.01	Function of S5	16	Multi-step speed 1
P25.02	Function of S6	17	Multi-step speed 2
P25.03	Function of S7	18	Multi-step speed 3
P25.04	Function of S8	6	Coast to stop
P25.10	Expansion card input terminal polarity	0x08	Terminal polarity

Note: The macro parameter table does not contain some parameters that are factory default parameters.

5.3.4 Points for attention

1. If you only want to check whether the VFD runs properly, set P90.00=0 (Common mode).
2. If you perform empty-load commissioning, set P90.00 to 3 (Horizontal moving application macro), set P11.08 to 0x000 to disable underload protection, and set P90.12 and P90.13 to 0 to prevent the torque verification fault reporting caused by empty load.
3. During onsite commissioning, if the VFD terminal signal upward/downward running command is

inconsistent with the hook lifting/lowering, swap any two phase wires of VFD output terminals U, V, and W.

4. This macro can meet the requirements of most horizontal moving application cases, and the performance parameters have been optimized and do not need to be adjusted in most cases. If an exception occurs, see the function parameter chapter for adjustment or contact the technical support.

5.4 Tower crane slewing with vortex

5.4.1 Wiring

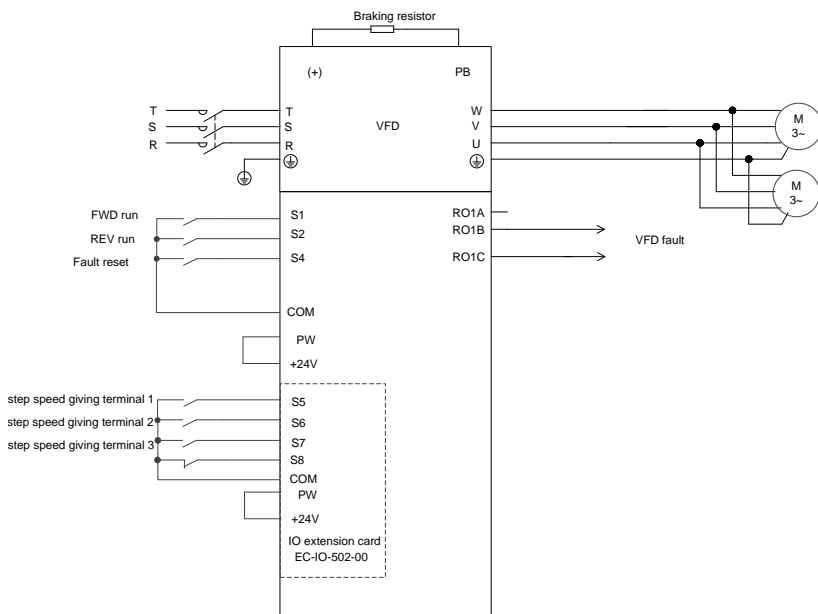

Figure 5-4 Wiring for tower crane slewing

Note: If the wiring is performed according to Figure 5-4, most VFD parameters need no adjustment. If the onsite function terminals are inconsistent with the terminals shown in the figure, adjust the input and output terminal functions according to the actual wiring after selecting this application macro.

5.4.2 Commissioning procedure

1. Check the wiring and ensure the wiring is proper.
2. Set P00.18=1 to restore to default settings.
3. Set motor nameplate parameters in P02.
4. Set P90.00=4 to select the application macro for tower crane slewing.

5. Perform low-speed trial run.

5.4.3 Macro parameters (P90.00=4)

Function code	Name	Setting	Remarks
P00.01	Channel of running commands	1	Terminal
P00.06	Setting channel of A frequency command	6	Multi-step speed running
P00.11	ACC time 1	10.0s	Low-frequency ACC time
P00.12	DEC time 1	18.0s	Low-frequency DEC time
P01.01	Starting frequency of direct start	1.50Hz	
P01.15	Stop speed	1.00Hz	
P05.03	Function of S3	0	No function
P05.04	Function of S4	7	Fault reset
P06.03	RO1 output	5	VFD in fault
P08.00	ACC time 2	15.0s	High-frequency ACC time
P08.01	DEC time 2	13.0s	High-frequency DEC time
P08.19	Switching frequency of ACC/DEC time	16.00Hz	If the running frequency is greater than P08.19, switch to ACC/DEC time 2.
P10.04	Multi-step speed 1	16.0%	Corresponding to the max. frequency
P10.06	Multi-step speed 2	32.0%	Corresponding to the max. frequency
P10.08	Multi-step speed 3	50.0%	Corresponding to the max. frequency
P10.10	Multi-step speed 4	70.0%	Corresponding to the max. frequency
P10.12	Multi-step speed 5	90.0%	Corresponding to the max. frequency
P25.01	Function of S5	16	Multi-step speed terminal 1
P25.02	Function of S6	17	Multi-step speed terminal 2
P25.03	Function of S7	18	Multi-step speed terminal 3
P25.04	Function of S8	6	Coast to stop
P25.10	Expansion card input terminal polarity	0x08	Coasting to stop is normally closed.

Note: The macro parameter table does not contain some parameters that are factory default parameters.

5.4.4 Points for attention

1. If you only want to check whether the VFD runs properly, set P90.00=0(Common mode).
2. If you perform empty-load commissioning, set P90.00=4 to select the application macro for tower crane slewing.
3. During onsite commissioning, if the VFD terminal signal forward/reverse running command is

inconsistent with the load running direction, adjust any two phase sequences of VFD output terminals U, V, and W.

- This macro can meet the requirements of most application cases for tower crane slewing, and the performance parameters have been optimized and do not need to be adjusted in most cases. If an exception occurs, see the function parameter chapter for adjustment or contact the technical support.

5.4.5 Controlling the vortex module through the HDO terminal

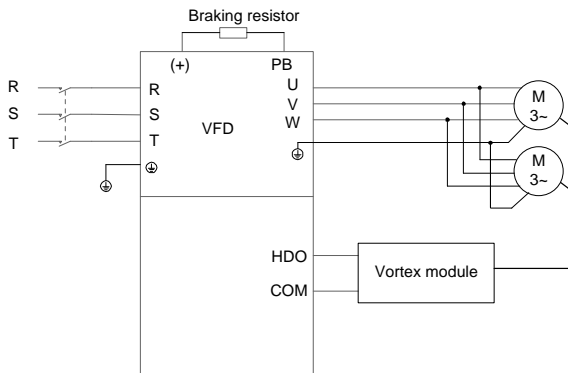

Figure 5-5 Connecting the HDO terminal to the vortex module

Commissioning procedure

- Connect the HDO terminal to the vortex module according to the figure.
- Set P91.37=1 to enable vortex control for tower crane rotating, and set P91.38 to adjust the carrier frequency of HDO.
- Set P91.38–P91.47 to adjust the vortex module output voltage change with frequency.

Note: The duty ratio that is output when bit1 of P06.05 is 1 decreases when the frequency increases. The vortex module output voltage decreases when the frequency increases.

Function code	Name	Setting	Setting								
P06.05	Output terminal polarity selection	Used to set the polarity of output terminals. When a bit is 0, the input terminal is positive; when a bit is 1, the input terminal is negative.	2								
		<table border="1"> <tr> <td>BIT3</td> <td>BIT2</td> <td>BIT1</td> <td>BIT0</td> </tr> <tr> <td>RO2</td> <td>RO1</td> <td>HDO</td> <td>Y</td> </tr> </table>	BIT3	BIT2	BIT1	BIT0	RO2	RO1	HDO	Y	
BIT3	BIT2	BIT1	BIT0								
RO2	RO1	HDO	Y								

Function code	Name	Setting	Setting
		Setting range: 0x0–0xF	
P91.37	Enabling HDO based vortex control for tower crane slewing	1: HDO is used as PWM signal for voltage adjustment output.	1
P91.38	Frequency f0	P91.38 setting range: P91.40–P00.03	50.00Hz
P91.39	Duty ratio corresponding to frequency f0	(Max. output frequency) P91.40 setting range: P91.42–P91.38	100.0%
P91.40	Frequency f1	P91.42 setting range: P91.44–P91.40	40.00Hz
P91.41	Duty ratio corresponding to frequency f1	P91.44 setting range: P91.46–P91.42 P91.46 setting range: 0.00Hz– P91.44	95.0%
P91.42	Frequency f2	P91.39 , P91.41 , P91.43 , and P91.47	10.00Hz
P91.43	Duty ratio corresponding to frequency f2	setting range: 0.0%–100.0% Segmented adjustment is performed based on the cycle ratio and frequency.	90.0%
P91.44	Frequency f3		3.50Hz
P91.45	Duty ratio corresponding to frequency f3		84.5%
P91.46	Frequency f4		0.00Hz
P91.47	Duty ratio corresponding to frequency f4		0.0%
P91.48	HDO carrier frequency	0.5–10.0kHz	1.0kHz
P91.49	HDO closing delay during stop	0–100.0s	5.0s

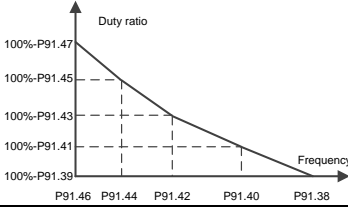

5.4.6 Controlling the vortex module through the AO terminal

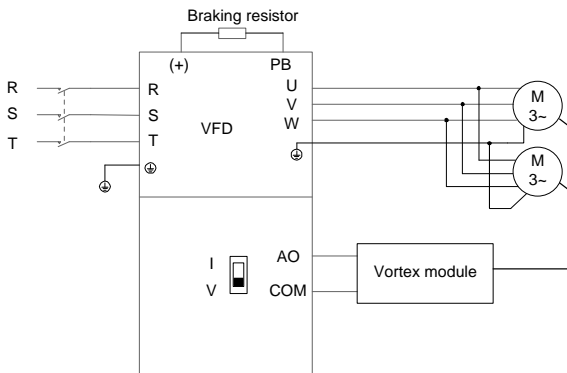

Figure 5-6 Connecting the AO terminal to the vortex module

Note: Turn SW2 on the control board to "V" for voltage output.

Controlling the vortex module through the AO terminal

1. Connect the AO terminal to the vortex module according to the figure.
2. Set P06.14=0 to select running frequency output for AO1.
3. Set P06.17–P06.21 to adjust the vortex module output voltage percentage.

The output voltage percentage is the ratio of running frequency to P00.03.

Function code settings:

Function code	Name	Description	Default
P06.14	AO1 output	0: Running frequency	0
P06.17	AO1 output lower limit	-300.0%–P06.19	16.0%
P06.18	AO1 output corresponding to lower limit	0.00V–10.00V	2.00V
P06.19	AO1 output upper limit	P06.17–300.0%	60.0%
P06.20	AO1 output corresponding to upper limit	0.00V–10.00V	10.00V
P06.21	AO1 output filter time	0.000s–10.000s	0.000s

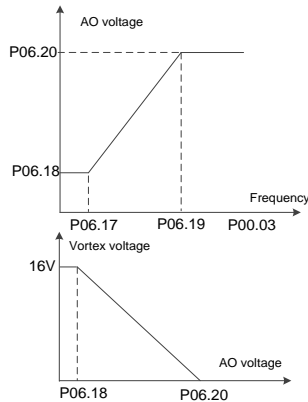

The relationship between the motor running frequency, AO voltage, and vortex voltage is as follows:

Running frequency	< 8Hz	8Hz	18Hz	30Hz	> 30Hz
AO voltage	2V	2V	5.64V	10V	10V
Vortex voltage	16V	16V	8.72V	0V	0V

5.5 Tower crane slewing without vortex in space voltage vector control

5.5.1 Wiring

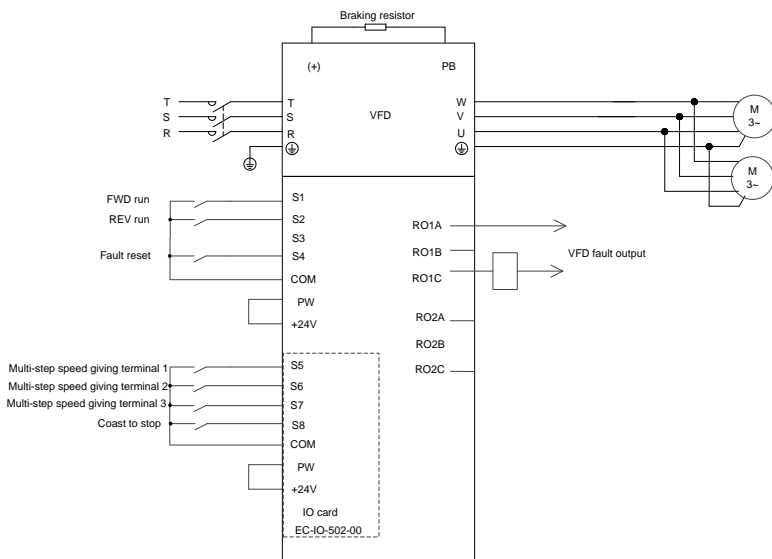

Figure 5-7 Wiring for tower crane rotating (without vortex) in space voltage vector control

Note: If the wiring is performed according to Figure 5-7, most VFD parameters need no adjustment. If the onsite function terminals are inconsistent with the terminals shown in the figure, adjust the input and output terminal functions according to the actual wiring after selecting this application macro.

5.5.2 Commissioning procedure

1. Check the wiring and ensure the wiring is proper.
2. Set P00.18=1 to restore to default settings.
3. Set motor nameplate parameters in P02.
4. Set P90.00=15 to select the application macro for tower crane slewing without vortex in space voltage vector control.
5. Perform low-speed trial run.

5.5.3 Macro parameters (P90.00=15)

Function code	Name	Setting	Remarks
P00.01	Channel of running commands	1	Terminal
P00.06	Setting channel of A	6	Multi-step speed running

Function code	Name	Setting	Remarks
	frequency command		
P00.11	ACC time 1	15.0s	Low-frequency ACC time
P00.12	DEC time 1	15.0s	Low-frequency DEC time
P01.05	ACC/DEC mode	2	Rotation application mode
P01.15	Stop speed	0.60Hz	
P05.04	Function of S4	7	Fault reset
P06.03	RO1 output	5	VFD in fault
P08.30	Frequency decrease ratio in drop control	10.00Hz	
P10.04	Multi-step speed 1	16.0%	Corresponding to the max. frequency, gear-1 speed
P10.06	Multi-step speed 2	32.0%	Corresponding to the max. frequency, gear-2 speed
P10.08	Multi-step speed 3	50.0%	Corresponding to the max. frequency, gear-3 speed
P10.10	Multi-step speed 4	70.0%	Corresponding to the max. frequency, gear-4 speed
P10.12	Multi-step speed 5	90.0%	Corresponding to the max. frequency, gear-5 speed
P11.00	Protection against phase loss	0x0100	
P11.05	Current limit mode	0x11	Software current-limit is enabled.
P11.06	Automatic current limit threshold	200.0%	
P11.14	Speed deviation detection value	50.0%	
P11.26	Enabling special functions	0x01	
P25.01	Function of S5	16	Multi-step speed 1
P25.02	Function of S6	17	Multi-step speed 2
P25.03	Function of S7	18	Multi-step speed 3
P86.01	Curve coefficient	80	
P86.02	Stop torque hold time	14.0s	
P86.12	Enabling direction change switchover	1	Enable
P86.14	Lagging value of direction change switchover basis time	130%	

Function code	Name	Setting	Remarks
P86.15	Direction change switchover retaining frequency	3.00Hz	

Note: The macro parameter table does not contain some parameters that are factory default parameters.

5.5.4 Points for attention

1. If you only want to check whether the VFD runs properly, set P90.00=0(Common mode).
2. If you perform empty-load commissioning, set P90.00=15 to select the application macro for tower crane slewing without vortex in space voltage vector control.
3. During onsite commissioning, if the VFD terminal signal forward/reverse running command is inconsistent with the load running direction, adjust any two phase sequences of VFD output terminals U, V, and W.
4. This macro can meet the requirements of most application cases for tower crane rotating (without vortex) in space voltage vector control, and the performance parameters have been optimized and do not need to be adjusted in most cases. If an exception occurs, see the function parameter chapter for adjustment or contact the technical support.

5.5.5 Wind resistance

In the control of tower crane slewing without vortex, the wind resistance function is mainly used to solve the problem of low working efficiency when the slewing mechanism is in upwind state and the running frequency is lower than the set frequency.

When the wind resistance function is enabled by setting P86.28=1, the the running frequency can reach the set frequency in upwind state during tower crane slewing without vortex.

Function code	Name	Setting	Remarks
P86.28	Channel of running commands	1	Terminal

5.6 Conical motor function

5.6.1 Wiring

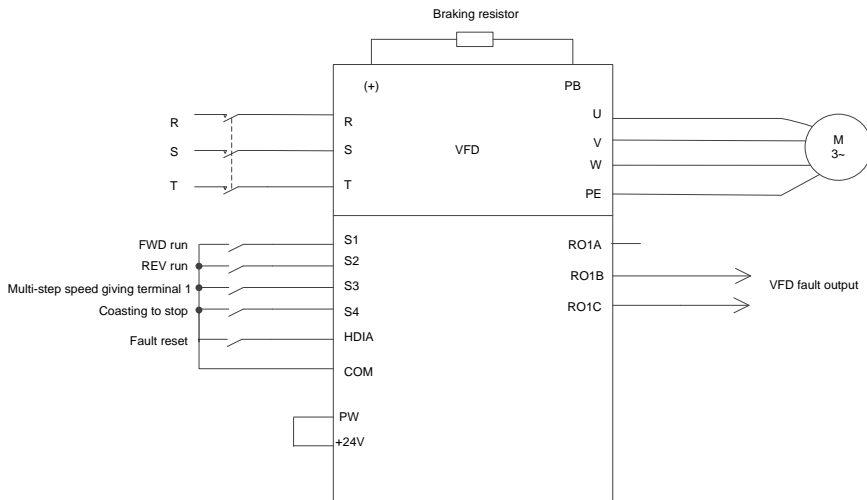

Figure 5-8 Wiring for the conical motor

Note: If the wiring is performed according to Figure 5-8, most VFD parameters need no adjustment. If the onsite function terminals are inconsistent with the terminals shown in the figure, adjust the input and output terminal functions according to the actual wiring after selecting this application macro.

5.6.2 Commissioning procedure

1. Check the wiring and ensure the wiring is proper.
2. Set P00.18=1 to restore to default settings.
3. Set motor parameters in P02.
4. Set P90.00=5 to select the conical motor application macro.
5. Perform low-speed trial run.

5.6.3 Macro parameters (P90.00=5)

Table 5-1 Parameter settings

Function code	Name	Setting	Remarks
P00.01	Channel of running commands	1	Terminal
P00.06	Setting channel of A frequency command	6	Multi-step speed running
P00.11	ACC time 1	3.0s	Time taken to accelerate from 0Hz to the max. frequency.
P00.12	DEC time 1	2.0s	Time taken to decelerate from

Function code	Name	Setting	Remarks
			the max. frequency to 0Hz.
P01.01	Starting frequency of direct start	2.00Hz	2.00Hz
P05.00	HDI input type	0x01	HDIA is digital input.
P05.03	Function of S3	16	Multi-step speed terminal 1
P05.04	Function of S4	6	Coast to stop
P05.05	Function of HDIA	7	Fault reset
P06.03	RO1 output	5	Fault output
P10.02	Multi-step speed 0	50.0%	50% of the max. output frequency P00.03
P10.04	Multi-step speed 1	100.0%	100% of the max. output frequency P00.03
P91.00	Enabling the conical motor function	1	Enabling the conical motor function

5.6.4 Points for attention

1. If you only want to check whether the VFD runs properly, set P90.00=0 (Common mode).
2. If the direction is incorrect when the heavy load runs upward during lifting in forward running mode, adjust any two phase sequences of VFD output terminals U, V, and W but not change the value of P00.13.
3. The starting frequency cannot be set too low. During onsite commissioning, ensure the starting frequency is set properly so that the brake can be turned on, and ensure the brake has been turned on before running.
4. The lifting ACC time can be 3s at most. If the ACC time is too long, the brake may not be opened.
5. The rated voltage must be at least 380V. If the grid rated voltage is too low (lower than 85% U_e), the brake cannot be opened; if the voltage is too low, the speed cannot be boosted.
6. When the conical motor performs constant-power variable-frequency speed regulation (boost), the max. rotational speed cannot exceed 1.2 times the rated speed (60Hz). Otherwise, the motor cannot run properly since the pressure spring cannot be pushed due to the axial magnetic pull force reduce, and therefore the VFD encounters the current limit or overcurrent fault.

5.7 Lifting in space voltage vector control

5.7.1 Wiring

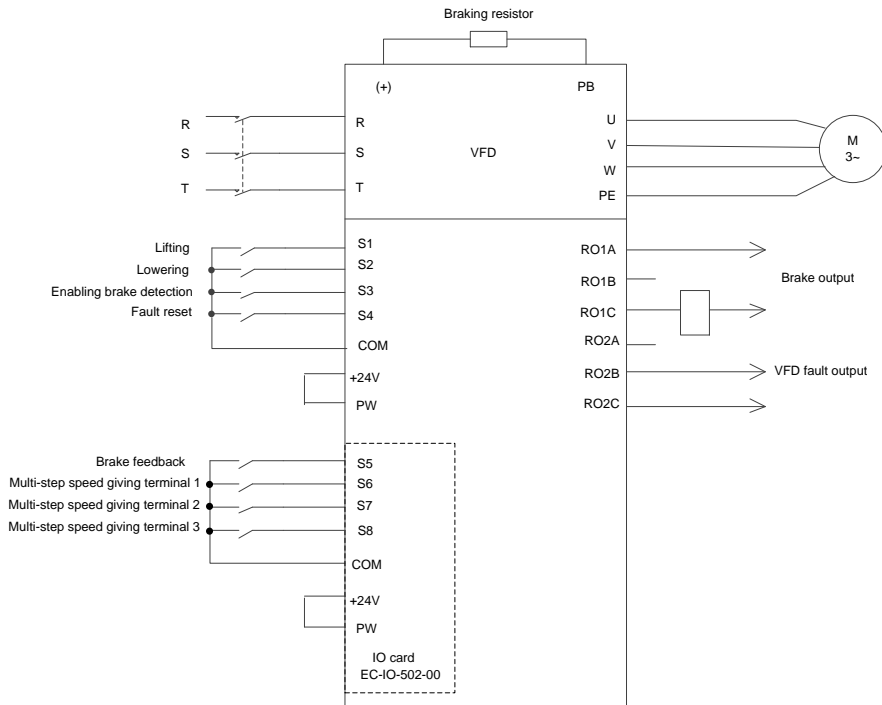

Figure 5-9 Wiring for lifting in space voltage vector control

Note: If the wiring is performed according to Figure 5-9, most VFD parameters need no adjustment. If the onsite function terminals are inconsistent with the terminals shown in the figure, adjust the input and output terminal functions according to the actual wiring after selecting this application macro.

5.7.2 Commissioning procedure

1. Check the wiring and ensure the wiring is proper.
2. Set P00.18=1 to restore to default settings.
3. Set motor parameters in P02.
4. Set P90.00=9 to select the space voltage vector controlled lifting application macro.
5. Perform low-speed trial run.

Note: In closed-loop mode, when the encoder is abnormal, set P90.00=9 to switch to the space voltage vector control mode. The two modes are different in the brake timing logic, and

therefore you need to adjust P01, P04, and P90 parameters accordingly.

5.7.3 Macro parameters (P90.00=9)

Function code	Name	Setting	Remarks
P00.01	Channel of running commands	1	Terminal
P00.03	Max. output frequency	100.00Hz	
P00.04	Upper limit of running frequency	100.00Hz	
P00.06	Setting channel of A frequency command	6	Multi-step speed run
P00.11	ACC time 1	8.0s	
P00.12	DEC time 1	8.0s	
P04.01	Torque boost of motor 1	0.1%	Disable automatic torque boost.
P04.02	Torque boost cut-off of motor 1	0.1%	
P04.40	Enabling I/F mode for AM 1	1	Enable the I/F mode.
P05.03	Function of S3	85	Enable brake detection
P05.04	Function of S4	7	Fault reset
P06.03	RO1 output	49	Brake output
P10.04	Multi-step speed 1	8.0%	
P10.06	Multi-step speed 2	20.0%	
P10.08	Multi-step speed 3	30.0%	
P10.10	Multi-step speed 4	40.0%	
P10.12	Multi-step speed 5	50.0%	
P11.08	VFD/motor OL/UL pre-alarm selection	0x021	Enable underload protection to enhance equipment safety.
P11.11	Underload pre-alarm detection threshold	15%	
P25.01	Function of S5	75	Brake feedback signal
P25.02	Function of S6	16	Multi-step speed 1
P25.03	Function of S7	17	Multi-step speed 2
P25.04	Function of S8	18	Multi-step speed 3
P90.04	Enabling brake-oriented logic	1	The brake is controlled by the VFD.
P90.12	Forward brake release current	50.0%	Corresponding to the motor rated current

Function code	Name	Setting	Remarks
P90.13	Reverse brake release current	50.0%	Corresponding to the motor rated current
P90.16	Forward brake release frequency	1.50Hz	
P90.17	Reverse brake release frequency	1.50Hz	
P90.18	Forward brake closing frequency	1.50Hz	
P90.19	Reverse brake closing frequency	1.50Hz	
P90.31	Enabling the monitoring on brake status	1	Enable the brake current monitoring (and brake feedback detection).

Note: The macro parameter table does not contain some parameters that are factory default parameters.

5.7.4 Points for attention

1. If you only want to check whether the VFD runs properly, set P90.00=0 (Common mode).
2. If you perform empty-load commissioning, set P90.00 to 9 (Lifting in space voltage vector control), set P11.08 to 0x000 to disable underload protection, and set P90.12 and P90.13 to 0 to prevent the torque verification fault reporting caused by empty load. In addition, if no external braking resistor is connected, you need to increase the ACC/DEC time to prevent the bus overvoltage fault reporting caused by too fast stop.
3. If there is a brake feedback signal, set P25.01 to 75, and the macro has set this parameter by default. In addition, set P90.31 to 1. If there is no brake feedback signal, set P90.31 to 0 to prevent the misreporting of a brake feedback fault.
4. During onsite commissioning, if the VFD terminal signal upward/downward running command is inconsistent with the load lifting/lowering direction, adjust any two phase sequences of VFD output terminals U, V, and W.
5. If PLC control is used, speed signal and other input and output signal functions need to be adjusted according to the actual control logic.
6. This macro can meet the requirements of most lifting application cases, and the performance parameters have been optimized and do not need to be adjusted in most cases. If an exception occurs, see the function parameter chapter for adjustment or contact the technical support.

5.8 Winching in closed-loop vector control (applicable to lifting in mineral wells and winches)

5.8.1 Wiring

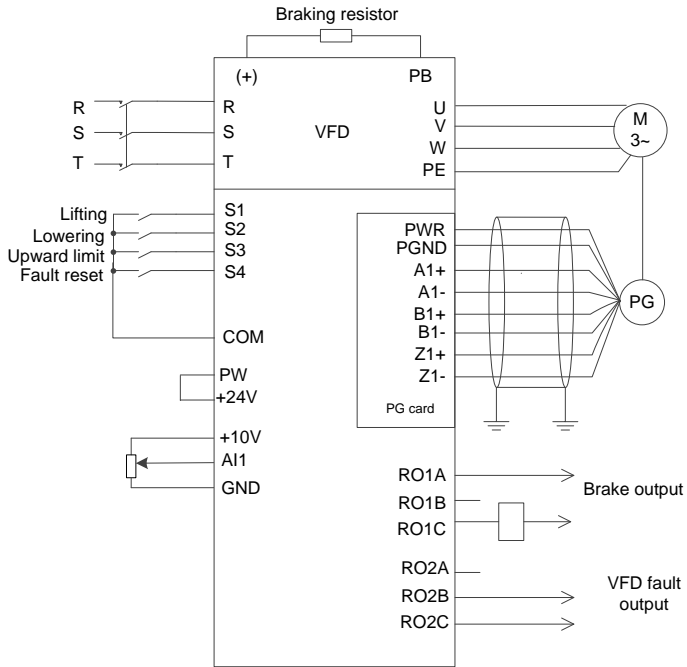

Figure 5-10 Wiring for winching in closed-loop vector control (recommended analog reference 0V–10V)

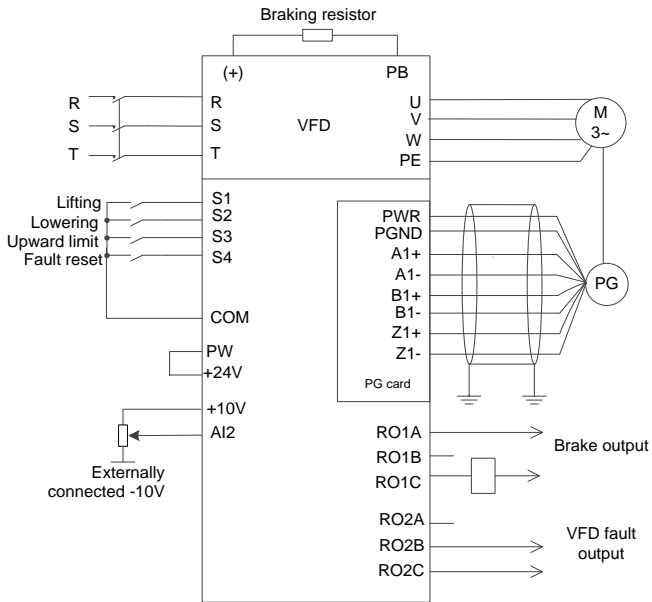

Figure 5-11 Wiring for winching in closed-loop vector control (using analog reference -10V~10V)

5.8.2 Commissioning procedure

1. Check the wiring and ensure the wiring is proper.
2. Set P00.18=1 to restore to default settings.
3. Set motor parameters in P02.
4. Set P00.15=2. The keypad displays "-FUN-". Press the RUN key to perform static autotuning.
5. Set the encoder type parameter P20.00, set the pulse per resolution (PPR) parameter P20.01. Perform low-speed upward running. Check the value of P18.00. If the value is negative, the encoder direction is reversed. Then you only need to set P20.02=0x001.
6. Set P90.00=11 to select the closed-loop vector controlled winching application macro.
7. Perform low-speed trial run.

5.8.3 Macro parameters (P90.00=11)

Table 5-2 Parameter settings for the closed-loop vector controlled winching application macro (recommended analog reference 0V~10V)

Function code	Name	Setting	Remarks
P00.00	Speed control mode	3	3: Closed-loop vector control mode
P00.01	Channel of running	1	Terminal

Function code	Name	Setting	Remarks
	commands		
P00.06	Setting channel of A frequency command	1	AI1
P00.07	Setting channel of B frequency command	0	Keypad
P00.11	ACC time 1	10.0s	
P00.12	DEC time 1	5.0s	
P01.15	Stop speed	0.20 Hz	
P05.03	Function of S3	64	Upward position limit
P05.04	Function of S4	5	Fault reset
P05.24	AI1 lower limit	0.20V	0.00V–P05.26. Adjust the value according to the actual situation.
P05.28	AI1 input filter time	0.100s	0.000s–10.000s
P06.03	RO1 output	49	Brake output
P06.04	RO2 output	5	VFD in fault
P90.04	Enabling brake-oriented logic	1	The brake is controlled by the VFD.
P90.14	Forward brake release torque	50.0%	Corresponding to the motor rated torque
P90.15	Reverse brake release torque	50.0%	Corresponding to the motor rated torque
P90.16	Forward brake release frequency	1.00Hz	
P90.17	Reverse brake release frequency	1.00Hz	
P90.18	Forward brake closing frequency	1.00Hz	
P90.19	Reverse brake closing frequency	1.00Hz	

Table 5-3 Parameter settings for the closed-loop vector controlled winching application macro (using analog reference -10V–10V)

Function code	Name	Setting	Remarks
P00.00	Speed control mode	3	3: Closed-loop vector control mode
P00.01	Channel of running commands	1	Terminal

Function code	Name	Setting	Remarks
P00.06	Setting channel of A frequency command	2	AI2
P00.07	Setting channel of B frequency command	0	Keypad
P00.11	ACC time 1	10.0s	
P00.12	DEC time 1	5.0s	
P01.15	Stop speed	0.20 Hz	
P05.03	Function of S3	64	Upward position limit
P05.04	Function of S4	5	Fault reset
P05.29	AI2 lower limit	-10.00V	-10.00V–P05.31
P05.30	Corresponding setting of AI2 lower limit	100.0%	-300.0%–300.0%
P05.31	AI2 middle value 1	-0.10V	P05.29–P05.33
P05.32	Corresponding setting of AI2 middle value 1	0.0%	-300.0%–300.0%
P05.33	AI2 middle value 2	0.10V	P05.31–P05.35
P05.34	Corresponding setting of AI2 middle value 2	0.0%	-300.0%–300.0%
P05.35	AI2 upper limit	10.00V	P05.33–10.00V
P05.36	Corresponding setting of AI2 upper limit	100.0%	-300.0%–300.0%
P05.37	AI2 input filter time	0.100s	0.000s–10.000s
P06.03	RO1 output	49	Brake output
P06.04	RO2 output	5	VFD in fault
P90.04	Enabling brake-oriented logic	1	The brake is controlled by the VFD.
P90.14	Forward brake release torque	50.0%	Corresponding to the motor rated torque
P90.15	Reverse brake release torque	50.0%	Corresponding to the motor rated torque
P90.16	Forward brake release frequency	1.00Hz	
P90.17	Reverse brake release frequency	1.00Hz	
P90.18	Forward brake closing frequency	1.00Hz	
P90.19	Reverse brake closing	1.00Hz	

Function code	Name	Setting	Remarks
	frequency		

5.8.4 Points for attention

1. If you only want to check whether the VFD runs properly, set P90.00=0 (Common mode).
2. If you perform empty-load commissioning, set P90.00 to 11, and set P90.14 and P90.15 to 0, preventing the VFD from reporting the torque verification fault tPF due to empty load. If no braking resistor is externally connected, increase the ACC/DEC time, preventing the VFD from reporting the bus overvoltage fault due to fast stop.
3. During onsite commissioning, if the VFD terminal signal upward/downward running command is inconsistent with the load lifting/lowering direction, adjust any two phase sequences of VFD output terminals U, V, and W.
4. This macro can meet the requirements of most closed-loop vector controlled winching application cases, and the performance parameters have been optimized and do not need to be adjusted in most cases. If an exception occurs, see the function parameter chapter for adjustment or contact the technical support.

5.8.5 How to use the -10→+10V analog operating lever

When the analog reference is -10V→+10V, AI2 must be used, and the values of P05.29, P05.30, P05.31, and P05.35 must be increased in order.

The following figure shows the mapping between analog reference and frequency setting.

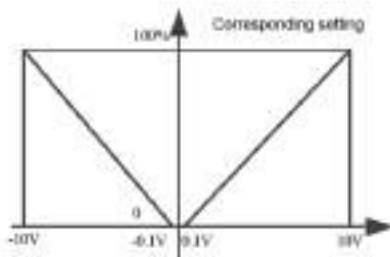

Figure 5-12 Corresponding frequency settings of AI2 analog input (analog reference of -10V→+10V)

5.9 Winching in open-loop vector control (applicable to lifting in mineral wells and winches)

5.9.1 Wiring

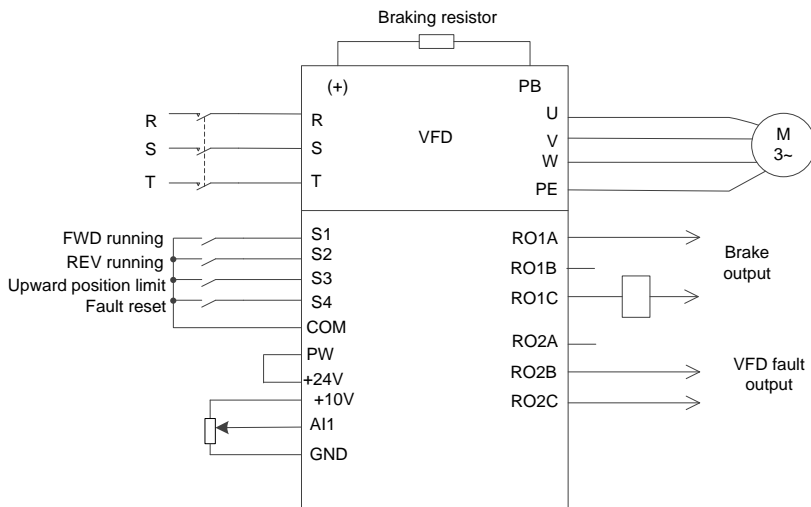

Figure 5-13 Wiring for winching in open-loop vector control (recommended analog reference 0V–10V)

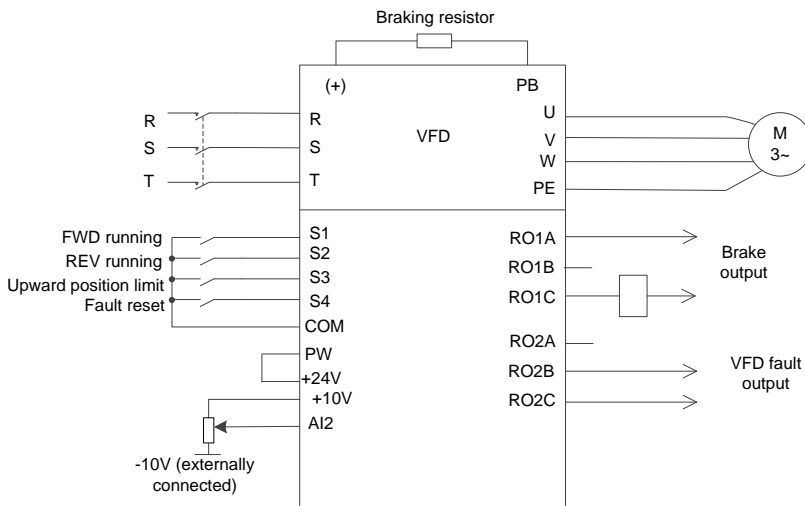

Figure 5-14 Wiring for winching in open-loop vector control (using analog reference -10V–10V)

Note: If the onsite function terminals are inconsistent with the terminals shown in the wiring diagrams, select the open-loop vector controlled winching application macro and adjust the input and output terminal functions according to the actual wiring. The recommended analog reference is 0V–10V.

5.9.2 Commissioning procedure

1. Check the wiring and ensure the wiring is proper.
2. Set P00.18=1 to restore to default settings.
3. Set motor parameters in P02.
4. Set P00.15=2. The keypad displays "-FUN-". Press the RUN key to perform static autotuning.
5. Set P90.00=12 to select the open-loop vector controlled winching application macro.
6. Perform low-speed trial run.

5.9.3 Macro parameters (P90.00=12)

Table 5-4 Parameter settings for the open-loop vector controlled winching application macro (recommended analog reference 0V–10V)

Function code	Name	Setting	Remarks
P00.00	Speed control mode	1	Sensorless vector control (SVC) mode 1
P00.01	Channel of running commands	1	Terminal
P00.06	Setting channel of A frequency command	1	AI1
P00.07	Setting channel of B frequency command	0	Keypad
P00.11	ACC time 1	10.0s	
P00.12	DEC time 1	5.0s	
P05.03	Function of S3	64	Upward position limit
P05.04	Function of S4	5	Fault reset
P05.24	AI1 lower limit	0.20V	0.00V–P05.26. Adjust the value according to the actual situation.
P05.28	AI1 input filter time	0.100s	0.000s–10.000s
P06.03	RO1 output	49	Brake output
P06.04	RO2 output	5	VFD in fault
P90.04	Enabling brake-oriented logic	1	The brake is controlled by the VFD.
P90.14	Forward brake release torque	50.0%	Corresponding to the motor rated torque

Function code	Name	Setting	Remarks
P90.15	Reverse brake release torque	50.0%	Corresponding to the motor rated torque
P90.16	Forward brake release frequency	2.00Hz	
P90.17	Reverse brake release frequency	2.00Hz	
P90.18	Forward brake closing frequency	2.00Hz	
P90.19	Reverse brake closing frequency	2.00Hz	

Table 5-5 Parameter settings for the open-loop vector controlled winching application macro (using analog reference -10V~10V)

Function code	Name	Setting	Remarks
P00.00	Speed control mode	1	Sensorless vector control (SVC) mode 1
P00.01	Channel of running commands	1	Terminal
P00.06	Setting channel of A frequency command	2	AI2
P00.07	Setting channel of B frequency command	0	Keypad
P00.11	ACC time 1	10.0s	
P00.12	DEC time 1	5.0s	
P05.03	Function of S3	64	Upward position limit
P05.04	Function of S4	5	Fault reset
P05.29	AI2 lower limit	-10.00V	-10.00V~P05.31
P05.30	Corresponding setting of AI2 lower limit	100.0%	-300.0%~300.0%
P05.31	AI2 middle value 1	-0.10V	P05.29~P05.33
P05.32	Corresponding setting of AI2 middle value 1	0.0%	-300.0%~300.0%
P05.33	AI2 middle value 2	0.10V	P05.31~P05.35
P05.34	Corresponding setting of AI2 middle value 2	0.0%	-300.0%~300.0%
P05.35	AI2 upper limit	10.00V	P05.33~10.00V

Function code	Name	Setting	Remarks
P05.36	Corresponding setting of AI2 upper limit	100.0%	-300.0%–300.0%
P05.37	AI2 input filter time	0.100s	0.000s–10.000s
P06.03	RO1 output	49	Brake output
P06.04	RO2 output	5	VFD in fault
P90.04	Enabling brake-oriented logic	1	The brake is controlled by the VFD.
P90.14	Forward brake release torque	50.0%	Corresponding to the motor rated torque
P90.15	Reverse brake release torque	50.0%	Corresponding to the motor rated torque
P90.16	Forward brake release frequency	2.00Hz	
P90.17	Reverse brake release frequency	2.00Hz	
P90.18	Forward brake closing frequency	2.00Hz	
P90.19	Reverse brake closing frequency	2.00Hz	

5.9.4 Points for attention

1. If you only want to check whether the VFD runs properly, set P90.00=0 (Common mode).
2. If you perform empty-load commissioning, set P90.00 to 12, and set P90.14 and P90.15 to 0, preventing the VFD from reporting the torque verification fault tPF due to empty load. If no braking resistor is externally connected, increase the ACC/DEC time, preventing the VFD from reporting the bus overvoltage fault due to fast stop.
3. During onsite commissioning, if the VFD terminal signal upward/downward running command is inconsistent with the load lifting/lowering direction, adjust any two phase sequences of VFD output terminals U, V, and W.
4. This macro can meet the requirements of most open-loop vector controlled winching application cases, and the performance parameters have been optimized and do not need to be adjusted in most cases. If an exception occurs, see the function parameter chapter for adjustment or contact the technical support.

5.10 Electric potentiometer

5.10.1 Wiring

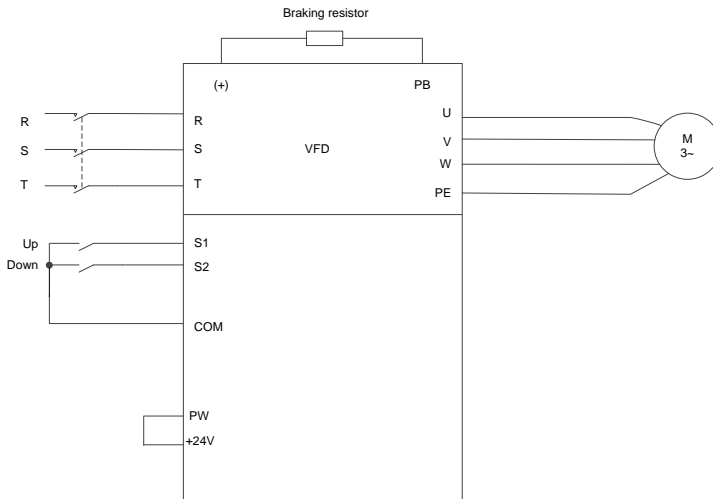

Figure 5-15 Electric potentiometer wiring

5.10.2 Commissioning procedure

1. Check the wiring and ensure the wiring is proper.
2. Set P00.18=1 to restore to default settings.
3. Set motor parameters in P02.
4. Set P05.01=10 and P05.02=11 to specify the **UP/DOWN** terminals.
5. Set P08.44 to set terminal control validity, and set P08.45 and P08.46 to set the increase/decrease change rate of the **UP/DOWN** terminal frequency.
6. Press **UP/DOWN** to run.

The following figure shows the electric potentiometer.

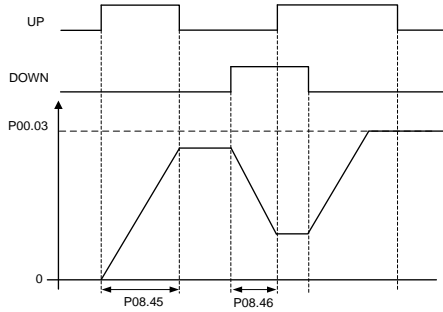

Figure 5-16 Electric potentiometer commissioning diagram

5.10.3 Electric potentiometer commissioning parameters

Table 5-6 Electric potentiometer commissioning parameters

Function code	Name	Setting	Remarks
P00.03	Max. output frequency	50	Used to set the max. output frequency of the VFD.
P05.01	Function of S1	10	Increase frequency setting (UP)
P05.02	Function of S2	11	Decrease frequency setting (DOWN)
P08.44	UP/DOWN terminal control setting	0x000	0x000–0x221 Ones place: Frequency setting selection 0: The setting made through UP/DOWN is valid. 1: The setting made through UP/DOWN is invalid. Tens place: Frequency control selection 0: Valid only when P00.06 =0 or P00.07 =0 1: Valid for all frequency setting methods 2: Invalid for multi-step speed running when multi-step speed running has the priority Hundreds place: Action selection for stop 0: Setting is valid. 1: Valid during running, cleared after

Function code	Name	Setting	Remarks
			stop 2: Valid during running, cleared after a stop command is received
P08.45	Frequency increment integral rate of the UP terminal	0.50Hz/s	0.01–50.00Hz/s
P08.46	Frequency integral rate of the DOWN terminal	0.50Hz/s	0.01–50.00Hz/s

5.11 Brake

5.11.1 Brake function in space voltage vector control

- Set P90.04 to 1 to enable the brake function.
- Set relay brake output. If RO2 is connected to the braking contactor, set P06.04 to 49.
- If the brake contactor has the feedback function, connect the brake feedback wire to an input terminal, for example, S3. Then set P05.03 to 75 indicating brake feedback signal. Set P90.31 to 1 to enable brake feedback detection. If the brake contactor does not provide the feedback function, ignore this.
- In lifting application, enable the I/F function, set P04.40 to 1, set P04.41, and set P04.52. In horizontal moving application, you can choose whether to enable the I/F function.
- Set P90.12 (Forward brake release current) and P90.13 (Reverse brake release current) to ensure there is enough torque before the brake is opened.
- Set the brake timing, including the forward/reverse brake release frequency, forward/reverse brake closing frequency, delay before forward brake release (T1), delay before reverse brake release (T5), delay after forward brake release (T2), delay after reverse brake release (T6), delay before forward brake closing (T3), delay before reverse brake closing (T7), delay after forward brake closing (T4), and delay after reverse brake closing (T8).

Note: If delay before reverse brake release (T5), delay after reverse brake release (T6), delay before reverse brake closing (T7), and delay after reverse brake closing (T8) are set to 0, the delay parameters for forwarding running are used.

- Perform trial run and check whether the brake timing is correct.

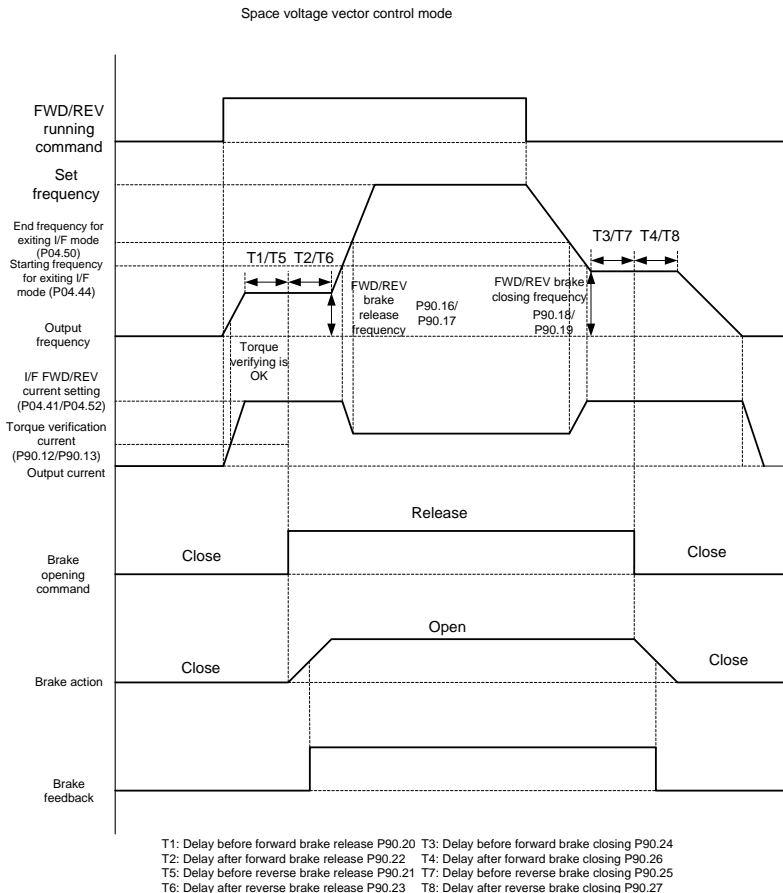

8. Adjust braking comfortability, which can be implemented by using the following methods.

A. In I/F mode, you can decrease the brake release frequency and brake closing frequency and adjust the T1–T8 delay parameters in the timing sequence so that the impact is reduced. Note that the brake release frequency and brake closing frequency are greater than P01.01 (Starting frequency) and P01.15 (Stop speed) in most cases.

B. During the reverse-running stop, you can apply the forward torque, that is, for reverse-running start, you can perform forward brake release and then perform reverse running; for reverse-running stop, you can switch reverse running to forward running, close the brake, and then perform forward-running stop. This ensures there is no slip is felt during reverse start or stop. Forward torque is enabled by setting P90.05. The timing sequence is as follows:

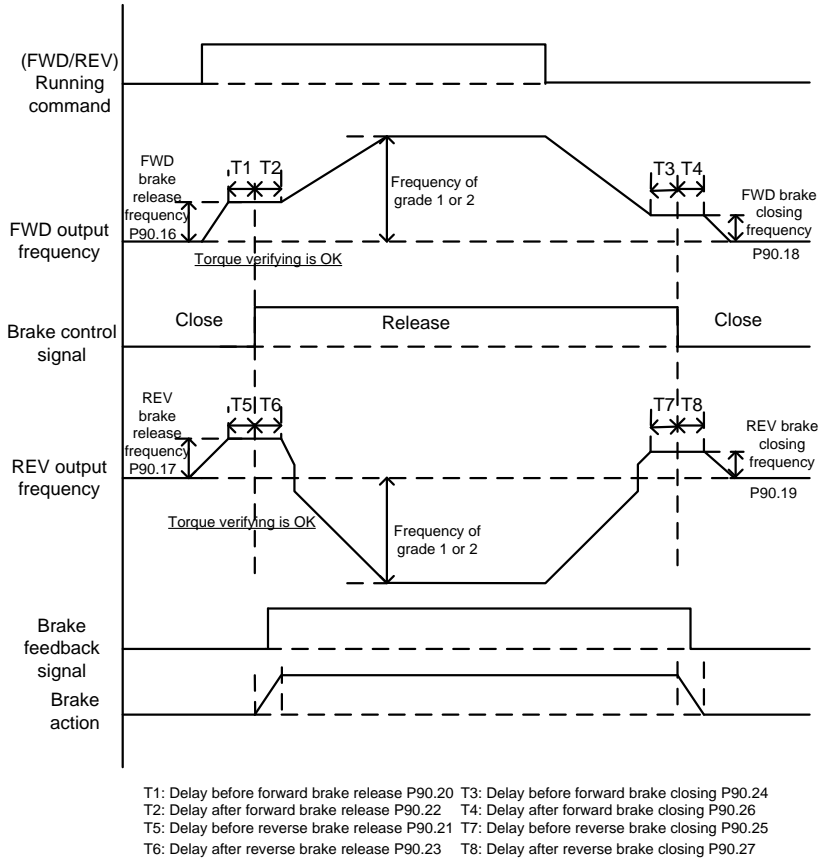

C. During the stop process, you can enable the maintenance frequency so that the device runs at a low speed within a small period of time before the stop, since impact may be caused if the device directly stops at a high speed. The maintenance frequency for stop can be enabled by setting P90.29 to a value greater than 0. You can set the maintenance frequency through P90.28. The timing diagram is as follows:

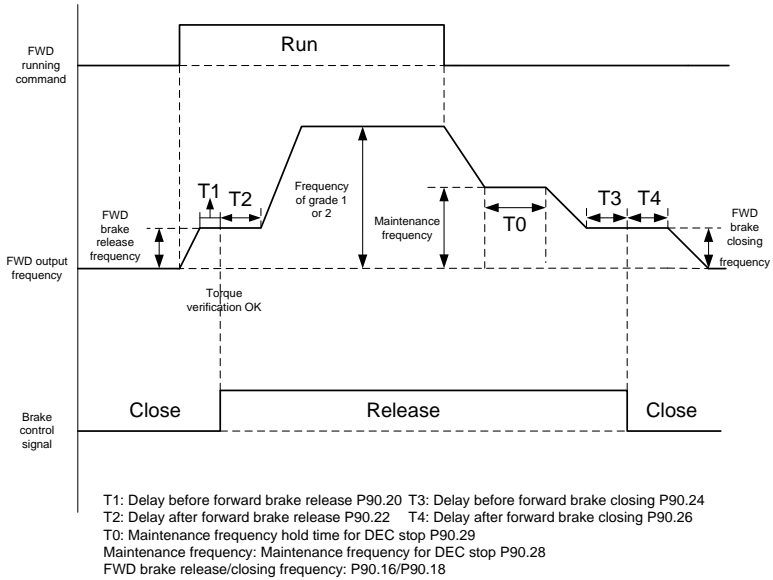

D. If two segments of ACC/DEC time are used, you can increase ACC/DEC time at low frequency running to ensure smoothness at low-frequency start or stop. You can set P08.19 (Switching frequency of ACC/DEC time) to a value greater than 0 to enable two segments of ACC/DEC time and then the ACC/DEC time 1 (P00.11 and P00.12) and ACC/DEC time 2 (P08.00 and P08.01) are used.

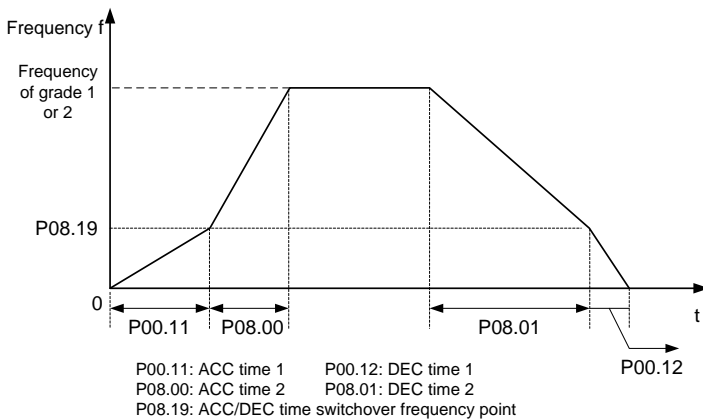

5.11.2 Brake function in open/closed-loop vector control

1. Set P90.04 to 1 to enable the brake function.
2. Set relay brake output. If RO1 is connected to the braking contactor, set P06.03 to 49.
3. If the brake contactor has the feedback function, connect the brake feedback wire to an input terminal, for example, S6. Then set P25.02 to 75 indicating brake feedback signal. Set P90.31 to 1 to enable brake feedback detection. In closed-loop mode, the brake current monitoring function is enabled automatically. If a brake exception occurs, a protection method is applied depending on the present current and the value of P90.34. Skip this step if the braking contactor has no feedback function.
4. Set P90.14 (Forward brake release torque) and P90.13 (Reverse brake release torque) to ensure there is enough torque before the brake is opened. You do not need to set P90.12 and P90.13.
5. Set the brake timing, including the forward/reverse brake release frequency, forward/reverse brake closing frequency, delay before forward brake release (T1), delay before reverse brake release (T5), delay after forward brake release (T2), delay after reverse brake release (T6), delay before forward brake closing (T3), delay before reverse brake closing (T7), delay after forward brake closing (T4), and delay after reverse brake closing (T8).
6. In closed-loop mode, you can decrease the brake release frequency and brake closing frequency and adjust the T1–T8 delay parameters in the timing sequence.
7. Perform trial run and check whether the brake timing is correct.

Open/closed loop vector control mode

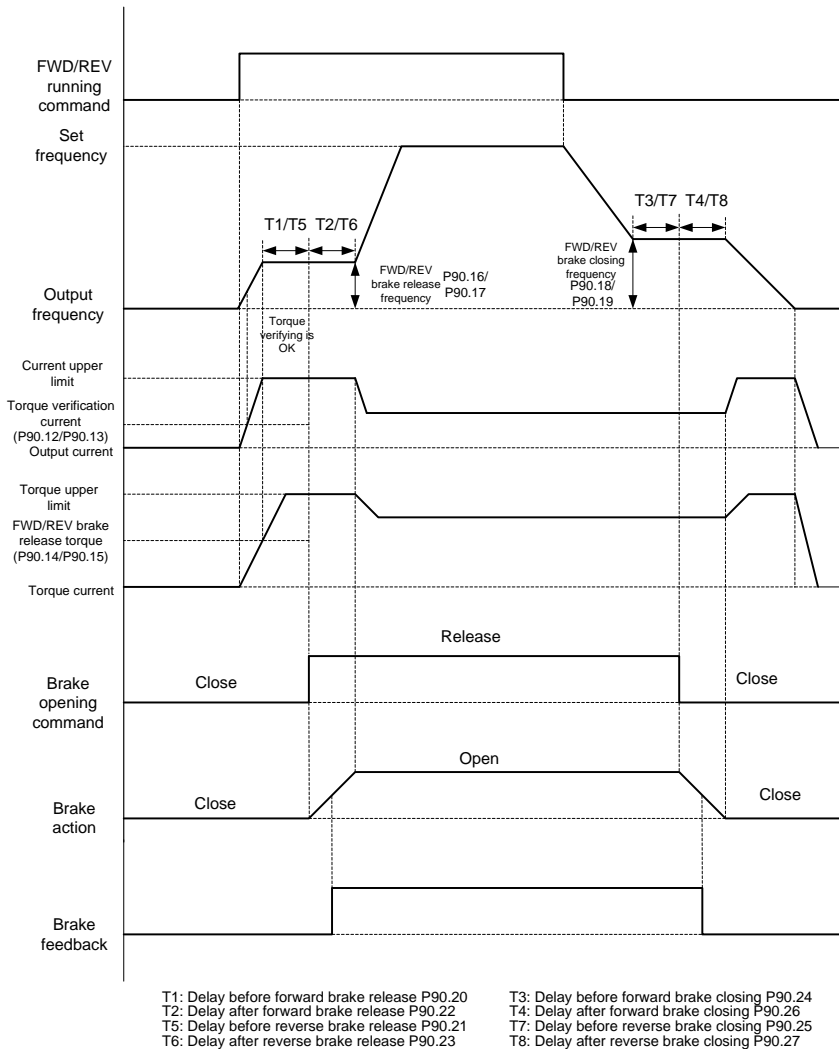

5.11.3 Description about torque verification and brake slip

After the VFD runs, the VFD output current or torque is checked before the brake release. If the VFD output current or torque is greater than the output current or torque setting (P90.12 or P90.15) and the situation lasts 60ms, torque verification succeeds. If torque verification does not pass after the

torque verification time P90.30 is reached, the torque verification fault tPF is reported.

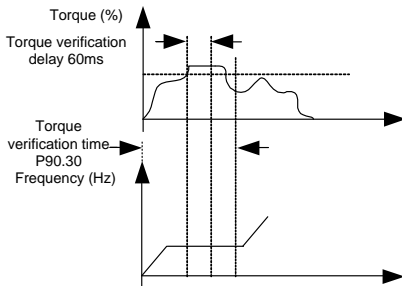

In closed-loop mode, if the brake slip fault delay P93.01 is greater than 0, the brake slip detection function is enabled. During torque verification, if the motor (encoder) speed is close to the brake release frequency and the situation duration exceeds P93.01, the brake failure fault bE is reported.

The torque verification and brake slip flowchart is as follows:

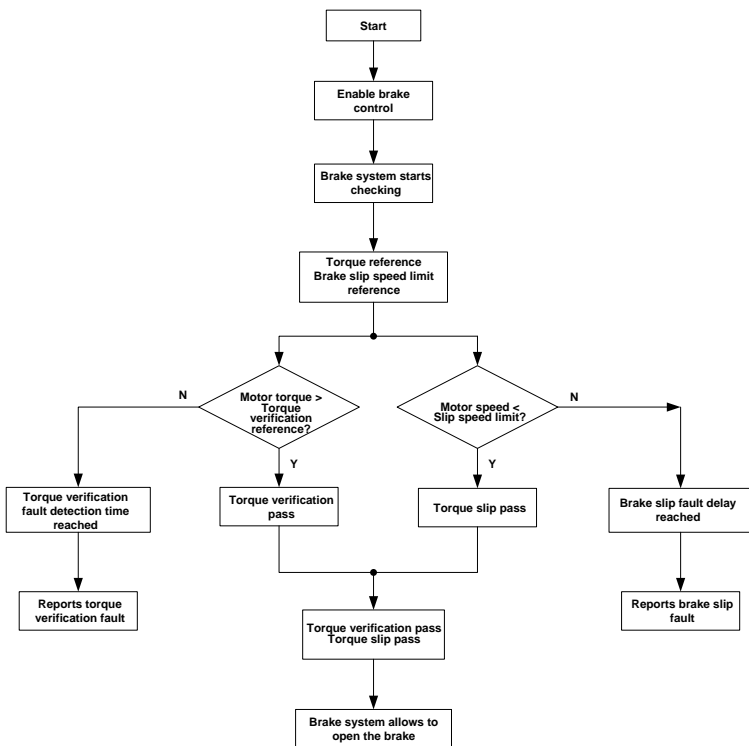

5.11.4 Commissioning parameters

Function code	Name	Description	Default
P90.04	Enabling brake-oriented logic	0–1 0: The brake is controlled by an external controller. 1: The brake is controlled by the VFD.	0
P90.05	Enabling forward torque for reverse-running start/stop	0x00–0x11 Ones place: indicates whether to enable forward torque for reverse-running start 0: Disable (The reverse-running start direction complies with the command.) 1: Enable (The reverse-running start direction is always the forward-running direction.) Tens place: indicates whether to enable forward torque for reverse-running stop 0: Disable (The reverse-running stop direction complies with the command.) 1: Enable (The reverse-running stop direction is always the forward-running direction.)	0x00
P90.12	Forward brake release current	0.0–200.0% (of the motor rated current)	0.0%
P90.13	Reverse brake release current	0.0–200.0% (of the motor rated current)	0.0%
P90.14	Forward brake release torque	0.0–200.0% (of the motor rated torque)	0.0%
P90.15	Reverse brake release torque	0.0–200.0% (of the motor rated torque)	0.0%
P90.16	Forward brake release frequency	0.00–20.00Hz	3.00Hz
P90.17	Reverse brake release	0.00–20.00Hz	3.00Hz

Function code	Name	Description	Default
	frequency		
P90.18	Forward brake closing frequency	0.00–20.00Hz	3.00Hz
P90.19	Reverse brake closing frequency	0.00–20.00Hz	3.00Hz
P90.20	Delay before forward brake release	0.000–5.000s	0.300s
P90.21	Delay before reverse brake release	0.000–5.000s The value 0 indicates the delay before forward brake release is used.	0.000s
P90.22	Delay after forward brake release	0.000–5.000s	0.300s
P90.23	Delay after reverse brake release	0.000–5.000s The value 0 indicates the delay after forward brake release is used.	0.000s
P90.24	Delay before forward brake closing	0.000–5.000s	0.300s
P90.25	Delay before reverse brake closing	0.000–5.000s The value 0 indicates the delay before forward brake closing is used.	0.000s
P90.26	Delay after forward brake closing	0.000–5.000s	0.300s
P90.27	Delay after reverse brake closing	0.000–5.000s The value 0 indicates the delay after forward brake closing is used.	0.000s
P90.28	Retaining frequency for stop	0.00–50.00Hz	5.00Hz
P90.29	Retaining frequency hold time for stop	0.00–5.000s	0.000s
P90.30	Torque verification fault detection time	0.00–10.000s	6.000s
P90.31	Enabling the monitoring on brake status	0–1 0: Disable	0
P90.32	Brake feedback exception delay (brake feedback detection time)	0.00–20.000S	1.000s
P90.33	Brake monitoring current threshold	0.0%–200.0% 100.0% corresponds to the motor rated current.	100.0%

Function code	Name	Description	Default
P90.34	Enabling speed reference under brake status error	0–1 0: Disable (The brake feedback fault is reported.) 1: Enable (The brake feedback alarm is also reported.)	0
P90.35	Speed reference under brake status error	0.00–50.00Hz	5.00Hz
P90.37	Brake selection for forward/reverse switchover	0–1 0: No switchover 1: Switchover	0
P93.01	Brake slip fault delay	0.000–5.000s The value 0 indicates brake slip is not detected, while a non-zero value indicates brake slip is detected.	0.500s

5.11.5 Brake function in torque control

If brake control (P90.04=1) is enabled when the torque mode is used (P03.32=1), the braking logic in the torque mode is enabled. When the VFD runs, the set torque is set based on (P90.42+5.0%). The FWD/REV frequency upper limit in the torque mode is given by the FWD/REV brake release frequency, and the output torque is detected in real mode. If the output torque is equal to or greater than the preset brake opening torque (P90.42), a delay before brake release is performed. When the delay is reached, brake output is performed. Then a delay after brake release is performed. When the delay is reached, the brake timing ends. The set torque and the FWD/REV frequency upper limit in the torque mode are restored to the normal values. That is, the parameters in P03 determine that the VFD runs in the normal torque mode.

During stop, the VFD automatically switches from the torque mode to the speed mode and then decelerates to stop. Then the brake logic uses the brake closing logic in the speed mode.

The brake timing diagram is as follows:

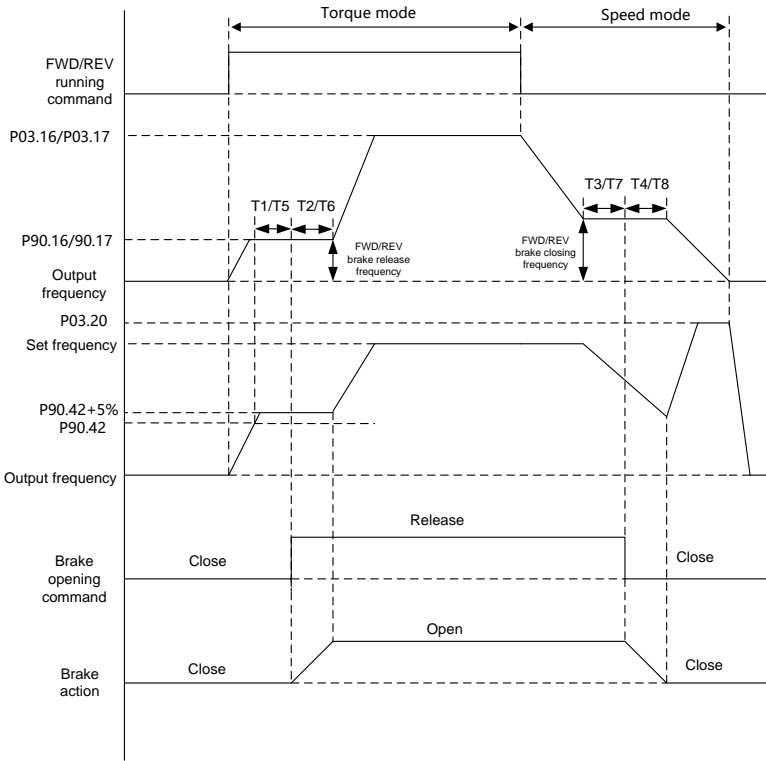

- T1: Delay before forward brake release P90.20
- T2: Delay after forward brake release P90.22
- T5: Delay before reverse brake release P90.21
- T6: Delay after reverse brake release P90.23
- T3: Delay before forward brake closing P90.24
- T4: Delay after forward brake closing P90.26
- T7: Delay before reverse brake closing P90.25
- T8: Delay after reverse brake closing P90.27

The function code settings are as follows:

For details about torque control function code settings, see section 6.5.5 Torque control.

The brake function code settings are as follows:

Function code	Name	Description	Setting
P90.04	Enabling brake-oriented logic	1: The brake is controlled by the VFD.	1
P90.05	Enabling forward torque for reverse-running start/stop	0x00–0x11 Ones place: indicates whether to enable forward torque for reverse-running start 0: Disable	0x00

Function code	Name	Description	Setting
		(The reverse-running start direction complies with the command.) 1: Enable (The reverse-running start direction is always the forward-running direction.) Tens place: indicates whether to enable forward torque for reverse-running stop 0: Disable (The reverse-running stop direction complies with the command.) 1: Enable (The reverse-running stop direction is always the forward-running direction.)	
P90.16	Forward brake release frequency	0.00–20.00Hz	3.00Hz
P90.17	Reverse brake release frequency	0.00–20.00Hz	3.00Hz
P90.18	Forward brake closing frequency	0.00–20.00Hz	3.00Hz
P90.19	Reverse brake closing frequency	0.00–20.00Hz	3.00Hz
P90.20	Delay before forward brake release	0.000–5.000s	0.300s
P90.21	Delay before reverse brake release	0.000–5.000s The value 0 indicates the delay before forward brake release is used.	0.000s
P90.22	Delay after forward brake release	0.000–5.000s	0.300s
P90.23	Delay after reverse brake release	0.000–5.000s The value 0 indicates the delay after forward brake release is used.	0.000s
P90.24	Delay before forward brake closing	0.000–5.000s	0.300s
P90.25	Delay before reverse brake	0.000–5.000s	0.000s

Function code	Name	Description	Setting
	closing	The value 0 indicates the delay before forward brake closing is used.	
P90.26	Delay after forward brake closing	0.000–5.000s	0.300s
P90.27	Delay after reverse brake closing	0.000–5.000s The value 0 indicates the delay after forward brake closing is used.	0.000s
P90.28	Retaining frequency for stop	0.00–50.00Hz	5.00Hz
P90.29	Retaining frequency hold time for stop	0.00–5.000S	0.000s
P90.30	Torque verification fault detection time	0.00–10.000S	6.000s
P90.31	Enabling the monitoring on brake status	0–1 0: Disable	0
P90.32	Brake feedback exception delay (brake feedback detection time)	0.00–20.000S	1.000s
P90.33	Brake monitoring current threshold	0.0%–200.0% 100.0% corresponds to the motor rated current.	100.0%
P90.34	Enabling speed reference under brake status error	0–1 0: Disable (The brake feedback fault is reported.) 1: Enable (The brake feedback alarm is also reported.)	0
P90.35	Speed reference under brake status error	0.00–50.00Hz	5.00Hz
P90.37	Brake selection for forward/reverse switchover	0–1 0: No switchover 1: Switchover	0
P93.01	Brake slip fault delay	0.000–5.000s The value 0 indicates brake slip is not detected, while a non-zero value indicates brake slip is detected.	0.500s
P90.40	Braking method in open-loop vector control	0–3 0: Common mode 1: Torque mode with limit 1 The limit is specified by P90.41.	0

Function code	Name	Description	Setting
		<p>2: Torque/speed switchover mode 1 (boost with braking) It is used when P90.04=1 since the brake is involved. When the brake is opened, the speed mode is automatically used.</p> <p>3: Torque/speed switchover mode 2 (horizontal moving) Since the brake is not involved, the torque/speed switchover is set through P90.44. The set frequency needs to be greater than P90.44.</p>	
P90.41	Torque limit 1 in open-loop vector control	Setting range: 0.0–300.0% (of the motor rated current) (P90.40=1 Torque limit mode)	120.0%
P90.42	Torque setting for brake release	0.0–200.0% During the running, when the torque feedback value is equal to or greater than P90.42, brake release timing is entered. (It is valid only when P90.04=1, which indicates the brake is controlled by the VFD, and the VFD uses the torque mode.)	50.0%
P90.44	Brake closing delay after stop DC braking starts	0.00–50.00Hz Used in torque/speed switchover mode 2	8.00Hz

5.12 Zero servo

5.12.1 Zero servo function description

The zero servo function needs to be used in closed-loop vector control. During stop, the VFD checks whether the pulse value is greater than P93.05. If yes, the VFD reports the brake failure alarm, and the output can be set through the relay. After the brake failure alarm protection input delay specified by P93.06 (if the pulse value is greater than triple the zero servo tolerance pulse threshold specified by P93.05 within the period, the delay specified by P93.06 is skipped), if P93.02=1 (Zero servo input slows down), the VFD runs downward slowly at the frequency specified by P93.03, and it coasts to stop when the slow lowering hold time specified by P93.04 is reached. Then the VFD performs detection again and repeats the preceding steps, which are cyclical. If P93.02=3, the hold time is

specified by P93.38. When the set time is reached, the zero servo input slows down.

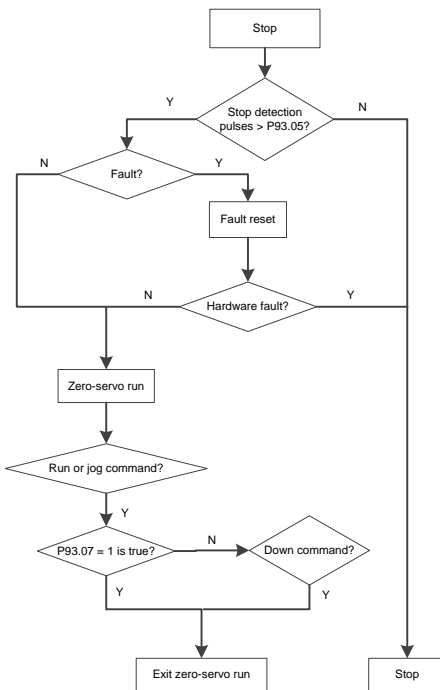

Note:

- At certain faults that cannot be reset, such as VFD internal hardware damaged, zero servo cannot be entered. At the faults that can be reset, with zero servo conditions met, zero servo can be entered.

The following faults cannot be reset:

Fault code	Fault type	Fault code	Fault type
OUt1	Inverter unit U-phase protection	ETH1	To-ground short-circuit fault 1
OUt2	Inverter unit V-phase protection	ETH2	To-ground short-circuit fault 2
OUt3	Inverter unit W-phase protection	STO	Safe torque off
UV	Bus undervoltage fault	STL1	Channel 1 safety circuit exception
SPI	Phase loss on input side	STL2	Channel 2 safety circuit exception
SPO	Phase loss on output side	STL3	Exception in both channels 1 and 2
OH1	Rectifier module overheat	OT	Motor overtemperature
OH2	Inverter module overheat	dIS	VFD disabled

Fault code	Fault type	Fault code	Fault type
EF	External fault	AdE	Analog speed reference deviation fault
ItE	Current detection fault	OtE1	PT100 overtemperature
bCE	Braking unit fault	OtE2	PT1000 overtemperature

- Every time zero servo is exited, torque verification is not performed only at the first running command giving, which means the verification is performed at all the following running command giving.
- When P93.02=2, the motor becomes hot, the fan cannot be mounted at the same shaft as the motor, and it must be independently controlled.

One zero servo period consists of the brake detection, brake failure alarm protection input delay, and slow lowering processes.

Zero servo slow lowering mode

The zero servo slow lowering process (P93.02=1) is as follows:

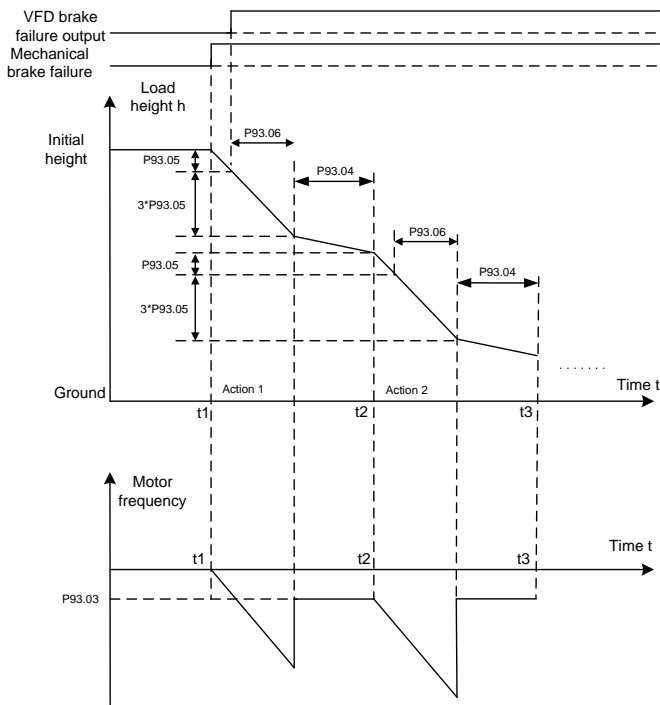

Note:

Zero speed keeping in zero servo: Setting P93.02=2 makes the motor locked at the positioning function in stop state. This means even if the motor is subjected to external forces, the VFD keeps the motor unmoved and the load stopped at the position where it stops.

Slow lowering after zero servo zero speed is kept: Setting P93.02=3 makes the VFD enter the zero speed keeping mode, of which the hold time is set through P93.38. When the hold time is reached, the slow lowering is automatically used.

After determining the hook slip protection distance, you can calculate the encoder pulses specified by P93.05 corresponding to the distance. The calculation principle is similar to that for height measuring in section 5.17.1.1. The formula is as follows.

$$\text{Zero servo tolerance pulse threshold} = (\text{Hook slip protection distance}) * (\text{Encoder PPR}) * (\text{Motor drum DEC ratio}) * (\text{Pulley set suspension ratio}) / (\pi * \text{Drum diameter})$$

In extreme cases (if the value of pulse change during zero servo determination is greater than 3 times P93.05, P93.06 is skipped directly), the zero servo is triggered until the actual slippage is 4 times the slip protection distance. If P93.06 is set to 0, zero servo is triggered at the hook slip protection distance. In other cases, zero servo is triggered at one to fourfold hook slip protection distance. At this time, the load falling speed is as follows:

$$\text{Load falling speed} = \sqrt{2g * \text{Actual hook slip distance}}$$

5.12.2 Zero servo function codes

Function code	Name	Description	Setting
P00.00	Speed control mode	3: Closed-loop vector control mode Note: Before using a vector control mode (0, 1, or 3), enable the VFD to perform motor parameter autotuning first.	3
P93.02	Zero servo protection mode	0-3 0: Disable zero servo 1: Zero servo input slows down 2: Zero servo input is always valid (keep running at zero speed) 3: Keep the zero speed (with the duration set through P93.38) and then enter the slow lowering mode	1
P93.03	Brake failure protection frequency	Setting range: P90.17 (Reverse brake release frequency)-8.00Hz	4.00Hz
P93.04	Slow lowering hold time	Setting range: 0.0s-30.0s	2.0s
P93.05	Zero servo	Setting range: 0-60000	20000

Function code	Name	Description	Setting
	tolerance pulse threshold		
P93.06	Brake failure alarm protection input delay	0–20.000s	0.5s
P93.07	Brake failure alarm protection reset method	0–1 0: Only for downward running 1: Both for upward and downward running	0
P93.38	Zero-servo zero-speed hold time	0–60mins	10

5.13 Anti-sway

The anti-sway function can be enabled by setting P85.00 or input terminal function 90.

This function requires obtaining the height in real time. The height can be obtained with any of the following methods:

Method 1: The height is measured by the lifting VFD, which is transmitted to the bridge and trolley VFDs through the CAN master/slave card. The transmitted rope height can be viewed through P94.05.

Method 2: The height is measured by the lifting VFD, which is transmitted to the cross and long travel mechanism VFDs. The transmitted rope height can be viewed through P94.33.

Method 3: The height is measured by an external mechanism, which is updated to P85.04 through communication. After the update takes effect, you can view it through P94.33.

The algorithm of anti-sway is solidified. You only need to set P85.01 and P85.05. When necessary, you can compensate the rope length by setting P85.04, or adjust P85.06 according to the demand of gear switchover.

The run curve of anti-sway output varies with the value of P85.01.

5.13.1 Commissioning procedure of anti-sway for tower cranes

1. Enable the anti-sway function by setting the trolley VFD function code P85.00=1 or S terminal function 90.
2. Set P85.01 and P85.05 of the trolley VFD.
3. If the rope length is obtained through CAN communication: Set the trolley VFD P85.02=0 and P28.00=2, which is configured as the slave, and P28.02=0x116, the rope length sent from the master to the slave.

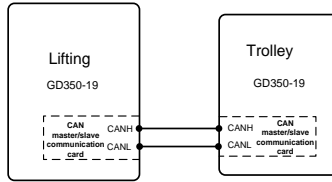

Tower crane application

If AI is used to transmit the rope height: Set the trolley VFD P85.02=1 or 2, and set the lifting VFD P06.14=35 (Rope hook length). P85.03 is the max. rope of the trolley VFD, so that the trolley receives the rope height from the lifting mechanism in real time. The same rule is used if HDI is used to transmit the rope height.

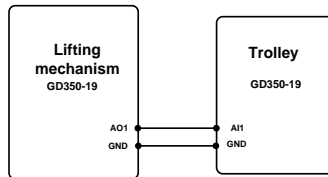

Tower crane application

If an external mechanism is used to measure the rope height: Write P85.04 (Height compensation value) directly.

4. Configure the lifting VFD to measure the height. After the height measuring, check whether P94.32 (height that the slave receives) and P94.05 (height that the master measures) are the same.
5. Perform low-speed trial run.

Note: For the first two methods, the rope length can be compensated through P85.04. When there is gear switchover need, you can adjust the value of P85.06.

5.13.2 Commissioning procedure of anti-sway for factory/port cranes (with one hook)

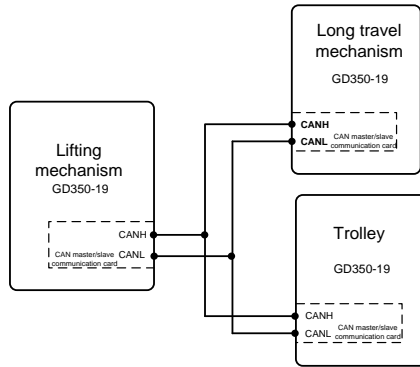

Application to a factory/port crane (with one hook)

1. Set lifting mechanism and trolley VFD parameters. Refer to section 5.13.1.
2. Set bridge VFD parameters, which are the same as trolley VFD parameters.

5.13.3 Commissioning procedure of anti-sway for factory/port cranes (with two hooks)

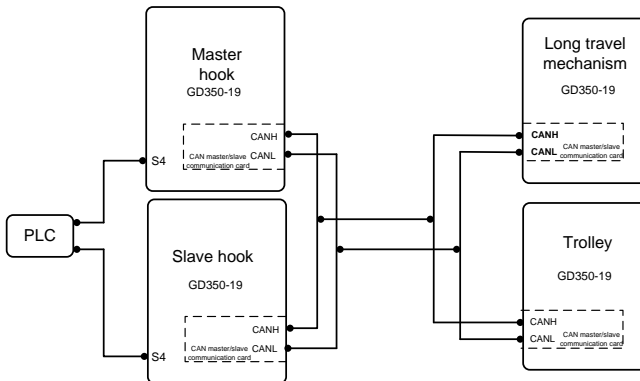

Application to a factory/port crane (with two hooks)

1. Set lifting mechanism, trolley, and long travel mechanism VFD parameters. Refer to section 5.13.2.
2. Set an S terminal (S4 for example in the figure) function to 91 (master/slave mode to a non master/slave mode) for the master hook and slave hook, and send a switchover signal through the PLC to select a master.

Note: Only one master is valid at a time.

5.13.4 Macro parameters

Trolley and long-travel mechanism VFD parameters

Function code	Name	Description	Setting
P85.00	Enabling anti-sway	1: Enable	1
P85.01	Pendulum reduction mode	0–2 0: Pendulum reduction mode 0 1: Pendulum reduction mode 1 2: Pendulum reduction mode 2 Note: For the pendulum reduction duration, Pendulum reduction mode 2 > Pendulum reduction mode 1 ≥ Pendulum reduction mode 0	0
P85.02	Rope length obtaining source	0: CAN master/slave card 1: AI1 2: AI2 3: AI3 4: HDIA 5: HDIB	0
P85.03	Max. rope length	5.00–150.00m	40.00
P85.04	Height (rope length) compensation value	0.00–150.00m	
P85.05	K coefficient (Damping ratio calculation)	0–1000	400
P85.06	Gear switchover filtering delay	0.000–10.000s	0.000
P85.12	Anti-sway and swing protection starting frequency	0.00–50.00Hz Applicable to pendulum reduction mode 0 (P85.01=0) and sway reducing mode (P85.00=2). When the set frequency change value is equal to or greater than P85.12, anti-sway or sway reducing is enabled; otherwise, normal ACC/DEC is enabled.	10.00Hz
P94.05	Measured height	0.00–655.35m (hook lowering distance) (As the master in master/slave control, it sends this value.)	
P94.31	Anti-sway status	0: No anti-sway 1: In anti-sway state 2: In sway reducing state	

Function code	Name	Description	Setting
P94.32	Obtained rope length	0–600.0m (As the slave in master/slave control, it receives this value.)	
P94.33	Rope length with compensation	0–600.0m	
P28.00	Master/slave mode	2: The local device is the slave.	2
P28.01	Master/slave communication data selection	0: CAN	0
P28.02	Master/slave control mode	Ones place: Master/slave running mode selection 6: Master/slave mode 6 Used for master/slave height transfer, in which the master sends the measured height to the slave. (You can check P94.05 to obtain the height sent from the master and P94.32 to obtain the height sent to the slave.) Tens place: Slave start command source 0: Master 1: Determined by <u>P00.01</u> Hundreds place: Whether to enable master/slave to send/receive data 0: Enable 1: Disable	0x116

Lifting VFD parameters

Function code	Name	Description	Setting
Communication			
P05.04	Function of S4	91: Switch from master/slave mode to a non master/slave mode	91
P06.14	AO1 output	35: Hook rope length	35
P06.16	HDO high-speed pulse output		35
P28.00	Master/slave mode	1: The local device is the master.	1
P28.01	Master/slave communication data	0: CAN	0

Function code	Name	Description	Setting
	selection		
P28.02	Master/slave control mode	<p>Ones place: Master/slave running mode selection</p> <p>6: Master/slave mode 6</p> <p>Used for master/slave height transfer, in which the master sends the measured height to the slave. (You can check P94.05 to obtain the height sent from the master and P94.32 to obtain the height sent to the slave.)</p> <p>Tens place: Slave start command source</p> <p>0: Master</p> <p>1: Determined by P00.01</p> <p>Hundreds place: Whether to enable master/slave to send/receive data</p> <p>0: Enable</p> <p>1: Disable</p>	0x116
Height measuring			
P93.08	Enabling height measuring	<p>0–1</p> <p>0: Disable</p> <p>1: Enable internal measuring (motor encoder) (In closed-loop mode, the encoder measures the speed and height.)</p> <p>2: Enable external measuring (HDI) (In open- and closed-loop modes, the pulley encoder measures the height.)</p> <p>Note: When P93.08=2, P20.15=0 indicates HDI measuring the height.</p>	1
P93.09	Mechanical transmission ratio	0.01–300.00	10.00
P93.10	Suspension ratio	1–4	1
P93.11	Rope length compensation	0.00–50.00m	0.00
P93.12	Cable diameter	0.1–100.0m	10.0mm
P93.13	Per-layer turns of drum winding	1–200	30
P93.14	Initial turns of drum winding	0–P93.11 (Per-layer turns of drum winding)	0

Function code	Name	Description	Setting
P93.15	Initial diameter of drum diameter	100.0–2000.0mm (Max. drum diameter in upward limit, including cable thickness)	600.0mm
P93.16	Enabling upward/downward limit position check	0x00–0x11 Ones place: 0: The upward limit position is not reached. 1: The upward limit position is reached. Tens place: 0: The downward limit position is not reached. 1: The downward limit position is reached. Note: Used for height measuring without upward or downward limit device.	0x00
P94.05	Measured height	0.00–655.35m (hook lowering distance) (As the master in master/slave control, it sends this value.)	
P94.06	Hight bits of measured height count value	0–65535	
P94.07	Low bits of measured height count value	0–65535	

5.14 Sway reducing

The sway reducing function can be enabled through function code P85.00 or input terminal function 92.

Compared with anti-sway, sway reducing achieves quick stop response without obtaining the height in real time, but there is still minor sway.

The algorithm of sway reducing is solidified. You only need to set P85.07 and P85.08. When necessary, you can adjust P85.06 according to the demand of gear switchover and adjust P85.09–P85.11 to reduce or increase the stop time.

5.14.1 Commissioning procedure

1. Set the VFD function P85.00 to 2 or use S terminal function 92 to enable sway reducing.
2. Set the VFD function codes P85.07 and P85.08.
3. Adjust P85.09–P85.11 to reduce or increase the stop time based on requirements. Note that the set frequency for the low gear is lower than 10.00Hz, that for the medium gear is in the range of 10.00–35.00Hz, and that for the high gear is above 35.00Hz.
4. Start low-speed run.

Note: You can adjust P85.06 according to the demand of gear switchover

5.14.2 Macro parameters

Function code	Name	Description	Setting
P85.00	Enabling anti-sway	2: Enable sway reducing	2
P85.05	K coefficient (Damping ratio calculation)	0–1000	400
P85.06	Gear switchover filtering delay	0.000–10.000s	0.100
P85.07	Anti-sway percentage	0–100	30
P85.08	Residual sway percentage	0–100	11
P85.09	ACC/DEC time of sway reducing at low gear	0.0–10.00s	2.00s
P85.10	ACC/DEC time of sway reducing at medium gear	0.0–10.00s	3.00s
P85.11	ACC/DEC time of sway reducing at high gear	0.0–10.00s	4.00s
P85.12	Anti-sway and swing protection starting frequency	0.00–50.00Hz Applicable to pendulum reduction mode 0 (P85.01=0) and sway reducing mode (P85.00=2). When the set frequency change value is equal to or greater than P85.12, anti-sway or sway reducing is enabled; otherwise, normal ACC/DEC is enabled.	10.00Hz

5.15 Master/slave control

5.15.1 Function description

Master/slave control is classified into power balance and speed synchronization.

1. Master/slave power balance

Master/slave power balance is a control method that distributes the load between two or more motors to achieve even balance. When a transmission device is driven by two or more motors, and two or more motor shafts are coupled with each other through gears, chains or conveyor belts, it is necessary to distribute the load between the motors through the master/slave control method to meet the control accuracy requirements.

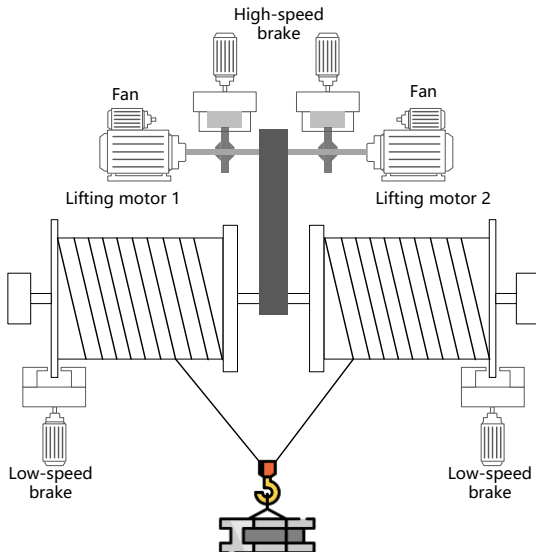

Figure 5-17 Mechanical structure diagram 1

In general, if multiple VFDs control multiple motors through belt connection, it is considered as flexible connection (or soft connection). When flexible connection is applied, generally, the slave adopts the speed control mode, and then the droop function is used to achieve better power balance performance. Therefore, in the terminal master/slave mode, master/slave mode a is recommended; in the CAN communication master/slave mode, master/slave mode 0 is recommended.

In general, if multiple VFDs control multiple motors through shaft, gear, or chain connection, it is considered as rigid connection (or hard connection). When rigid connection is applied, generally, the slave adopts the torque control mode for better power balance performance. Therefore, in the terminal master/slave mode, master/slave mode b is recommended; in the CAN communication master/slave mode, master/slave mode 1 is recommended.

2. Master/slave speed synchronization

Master/slave speed synchronization is used for the speed synchronization between two motors. Using the function requires that both motors have the encoder installed, and the VFD has the encoder pulse counting function. The mechanical structure is shown in the following figure:

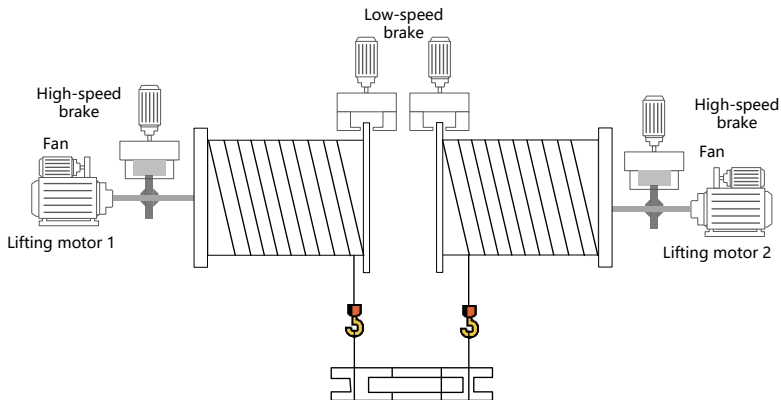

Figure 5-18 Mechanical structure diagram 2

Since master/slave speed synchronization requires speed consistency, the VFD must use the closed-loop mode. Therefore, only master/slave mode 4 in the CAN communication master/slave mode can be used.

5.15.2 Terminal master/slave function

A. Using the VFD high-speed pulse input terminal HDIA and high-speed pulse output terminal HDO to implement simplified master/slave control

The wiring diagram is as follows.



1. Terminal master/slave mode a

The master adopts the speed control mode and sends the ramp frequency to the slave HDIA terminal through the HDO terminal. The slave adopts the speed control mode and the frequency reference is set by the HDIA terminal. Then, adjust reduction ratio of droop control P08.30 of the slave to meet power balance.

Master parameters:

Function code	Name	Description	Setting
P06.00	HDO output type	0: Open collector high-speed pulse output 1: Open collector output	0
P06.16	HDO high-speed pulse output	2: Ramp reference frequency	2
P06.27	HDO output lower limit	-300.0%– P06.29	0.00%
P06.28	HDO output corresponding to lower limit	0.00–50.00Hz	0.00kHz
P06.29	HDO output upper limit	P06.27 –300.0%	100.0%
P06.30	HDO output corresponding to upper limit	0.00–50.00Hz	50.00 kHz

Slave parameters:

Function code	Name	Description	Setting
P00.06	Setting channel of A frequency command	0–15 4: High-speed pulse HDIA	4
P05.00	HDI input type	Ones place: HDIA input type 0: HDIA is high-speed pulse input Tens place: HDIB input type 0: HDIB is high-speed pulse input	0x00
P05.38	HDIA high-speed pulse input function selection	0: Input set through frequency 1: Reserved 2: Input set through encoder, used together with HDIB	0
P05.39	HDIA lower limit frequency	0.000 kHz – P05.41	0.000 kHz
P05.40	Corresponding setting of HDIA lower limit frequency	-300.0%–300.0%	0.0%
P05.41	HDIA upper limit frequency	P05.39 –50.000kHz	50.000 kHz
P05.42	Corresponding setting of HDIA upper limit frequency	-300.0%–300.0%	100.0%
P08.30	Frequency decrease ratio in drop control	0.00–50.00Hz	1.00Hz

2. Terminal master/slave mode b

The master adopts the speed control mode and sends the torque current to the slave HDIA terminal through the HDO terminal. The slave adopts the torque control mode and the torque reference is set by the HDIA terminal.

Master parameters:

Function code	Name	Description	Setting
P06.00	HDO output type	0: Open collector high-speed pulse output	0
P06.16	HDO high-speed pulse output	22: Torque current (relative to triple the motor rated current)	22

Slave parameters:

Function code	Name	Description	Setting
P03.11	Torque setting method	5: Pulse frequency HDIA	5
P03.32	Enabling torque control	1: Enable	1
P05.00	HDI input type	Ones place: HDIA input type 0: HDIA is high-speed pulse input Tens place: HDIB input type 0: HDIB is high-speed pulse input	0x00

B. Using the VFD analog input terminal (for example, AI1) and analog output terminal (for example, AO1) to implement simplified master/slave control

The wiring diagram is as follows.



1. Analog terminal master/slave mode a

The master adopts the speed control mode and sends the ramp frequency to the slave AI1 terminal through the AO1 terminal. The slave adopts the speed control mode and the frequency reference is set by the AI1 terminal. Then, adjust reduction ratio of droop control P08.30 of the slave to meet power balance.

Master parameters:

Function code	Name	Description	Setting
P06.14	AO1 output	2: Ramp reference frequency	2
P06.17	AO1 output lower limit	Setting range of P06.17 : -300.0%– P06.19 P06.18 setting range: 0.00V–10.00V P06.19 setting range: P06.17 –100.0% P06.20 setting range: 0.00V–10.00V P06.21 setting range: 0.000s–10.000s	0.0%
P06.18	AO1 output corresponding to lower limit		0.00V
P06.19	AO1 output upper limit		100.0%
P06.20	AO1 output corresponding to upper limit		10.00V
P06.21	AO1 output filter time		0.000s

Slave parameters:

Function code	Name	Description	Setting	
P00.06	Setting channel of A frequency command	1: AI1	1	
P05.24	AI1 lower limit	1: AI1	0.00V	
P05.25	Corresponding setting of AI1 lower limit		P05.24 setting range: 0.00V– P05.26 P05.25 setting range: -300.0%–300.0%	0.0%
P05.26	AI1 upper limit		P05.26 setting range: P05.24 –10.00V	10.00V
P05.27	Corresponding setting of AI1 upper limit		P05.27 setting range: -300.0%–300.0% P05.28 setting range: 0.000s–10.000s	100.0%
P05.28	AI1 input filter time		0.030s	
P08.30	Frequency decrease ratio in drop control		0.00–50.00Hz	1.00Hz

2. Analog terminal master/slave mode b

The master adopts the speed control mode and sends the torque current to the slave AI1 terminal through the AO1 terminal. The slave adopts the torque control mode and the torque reference is set by the AI1 terminal.

Master parameters:

Function code	Name	Description	Setting
P06.14	AO1 output	22: Torque current (relative to triple the motor rated current)	22
P06.17	AO1 output lower limit	Setting range of P06.17 : -300.0%– P06.19 P06.18 setting range: 0.00V–10.00V	0.0%
P06.18	AO1 output		0.00V

Function code	Name	Description	Setting
	corresponding to lower limit	P06.19 setting range: P06.17 –300.0% P06.20 setting range: 0.00V–10.00V	
P06.19	AO1 output upper limit	P06.21 setting range: 0.000s–10.000s	100.0%
P06.20	AO1 output corresponding to upper limit		10.00V
P06.21	AO1 output filter time		0.000s

Slave parameters:

Function code	Name	Description	Setting	
P03.11	Torque setting method	2: AI1	2	
P03.32	Enabling torque control	1: Enable	1	
P05.24	AI1 lower limit		0.00V	
P05.25	Corresponding setting of AI1 lower limit		P05.24 setting range: 0.00V– P05.26 P05.25 setting range: -300.0% –300.0%	0.0%
P05.26	AI1 upper limit		P05.26 setting range: P05.24 –10.00V	10.00V
P05.27	Corresponding setting of AI1 upper limit		P05.27 setting range: -300.0% –300.0% P05.28 setting range: 0.000s–10.000s	100.0%
P05.28	AI1 input filter time			0.030s

Note: When the terminal master/slave function is used, commissioning is unrelated to P28.

5.15.3 Master/slave communication

The VFDs can implement the master/slave control function by using the CAN master/slave communication card. The wiring diagram is as follows.

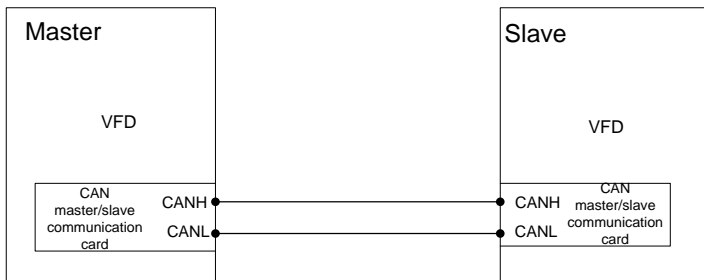

The specific CAN communication master/slave modes are: master/slave mode 0–2 are master/slave power balance modes, master/slave mode 4 is the master/slave speed synchronization mode, master/slave mode 5 is the closed-loop speed synchronization mode, master/slave mode 6 is the closed-loop height synchronization mode, master/slave mode 7 is the independent brake mode, while

master/slave mode 3 is reserved. Master/slave mode 0 and master/slave mode 1 are used often.

1. Master/slave mode 0 (P28.02 ones place=0)

Basic principle: Both the master and slave adopt the speed control mode, and the power balance is achieved by the droop control.

Commissioning method: Set P28.00 to 1 for the master, set P28.00 to 2 for the slave, set the ones place of P28.02 to 0 both for the master and slave, select master/slave mode 0, and adjust P28.03 for the slave based on the actual situation.

The master sends the running command and speed to the slave through CAN communication. The slave starts according to the command given by the master and runs according to the speed given by the master. At this time, adjust the droop frequency of the slave P08.30 to meet the power balance requirement.

2. Master/slave mode 1 (P28.02 ones place=1)

Basic principle: The master and slave must use the vector control mode of the same type, the master uses speed control, and the slave will be forced to use the torque control mode and use the master output torque as the reference torque.

Commissioning method: Set P28.00 to 1 for the master, set P28.00 to 2 for the slave, set the ones place of P28.02 to 1 both for the master and slave to select master/slave mode 1, and adjust P28.04 to set the torque gain for the slave and adjust P28.21 to increase or reduce the slave torque based on the actual situation. The slave will be switched to torque mode automatically, and therefore P03 parameters do not need to be adjusted.

The master sends the running command and speed to the slave through CAN communication. The slave starts according to the command given by the master and runs according to the torque given by the master.

3. Master/slave mode 2 (Combined mode, P28.02 ones place=2)

Basic principle: The slave starts in the speed control mode (master/slave mode 0) and then switches to the torque mode (master/slave mode 1) at a certain frequency point.

Commissioning method: Set P28.00 to 1 for the master, set P28.00 to 2 for the slave, set the ones place of P28.02 to 2 both for the master and slave to select master/slave mode 2, and adjust P28.03 and P28.04 for the slave based on the actual situation. In addition, set P28.05.

The master sends the running command, speed and torque to the slave through CAN communication. The slave starts according to the command given by the master and runs according to the speed given by the master if the switching frequency point is not reached but runs according to the torque given by the master if the switching frequency point is reached.

4. Master/slave mode 3 (Reserved)

5. Master/slave mode 4 (Closed-loop master/slave mode, speed synchronization mode)

Basic principle: In the position synchronization mode, speed synchronization means to compare the position pulse counts of the master and slave and correct the position pulse error at the slave side so as to reduce the error to 0. The master and slave must be equipped with encoders. The master and slave adopt speed control, using position pulse difference for speed correction.

Commissioning method:

Set P28.00 to 1 for the master, set P28.00 to 2 for the slave, and set the ones place of P28.02 to 4 both for the master and slave to select master/slave mode 4.

If there is a transmission ratio between the slave and master, set the P28.07, P28.08 and P28.09. When the pulse difference between the slave and master is greater than P28.09, a fault is reported directly. When the pulse difference between the slave and master is less than P28.08, speed correction is not performed. When the pulse difference between the slave and master is greater than P28.08 but less than P28.09, speed correction is performed, and adjust P28.12, P28.13, and P28.14 when necessary. In addition, you can set P28.10.

The master sends the running command, speed, and position pulse to the slave through CAN communication. The slave performs speed correction by comparing the local position pulse with the position pulse sent from the master.

6. Master/slave mode 5 (P28.02 ones place=5)

Basic principle: The master and slave must use the closed-loop vector control mode, the master uses speed control, and the slave will be forced to use the torque control mode and use the master output torque as the reference torque.

Commissioning method: Set P28.00 to 1 for the master, set P28.00 to 2 for the slave, set the ones place of P28.02 to 5 both for the master and slave, select master/slave mode 1, and adjust P28.04 to adjust the slave speed.

The master sends the running command, speed and torque to the slave through CAN communication. The slave starts according to the command given by the master and runs according to the torque given by the master.

7. Master/slave mode 6 (Anti-sway or sway reducing master/slave mode)

Basic principle: The master sends the actual height to the master to be used in the anti-sway algorithm, while the master and slave do not run synchronously.

Commissioning method: For details, see sections 5.13 and 5.14.

8. Master/slave mode 7 (Independent brake control based on master/slave mode 1)

Basic principle: Similar to master/slave mode 1, mode 7 features that brakes are independently controlled by the VFDs.

Commissioning method: Refer to master/slave mode 1. The brake timeout time can be adjusted through P28.22.

Note: Open-loop vector control is applicable only to master/slave modes 0–3, while closed-loop vector control is applicable to all the master/slave modes.

Function code	Name	Description	Default
P28.00	Master/slave mode	0: Master/slave control is invalid. 1: The local device is the master. 2: The local device is the slave.	0
P28.01	Master/slave mode selection	0: CAN 1: Reserved	0
P28.02	Master/slave control mode	Ones place: Master/slave running mode selection 0: Master/slave mode 0 The master and slave use speed control, with power balanced through droop control. 1: Master/slave mode 1 (The master and slave must be in the same type of vector control. When the master is in speed control, the slave is forced into torque control.) 2: Combined mode (Master/slave mode 2) The slave switches from speed mode (master/slave mode 0) to torque mode (master/slave mode 1) at a frequency point. 3: Master/slave mode 3 (Reserved) (Both the master and slave adopt speed control, and the slave performs power balance depending on the speed loop integral result of the master.) 4: Closed-loop master/slave mode (Master/slave mode 4) The master and slave must be equipped with encoders. The master and slave adopt speed control, using position pulse difference for speed correction. 5: Master/slave mode 5 (Both the master and slave adopt closed-loop speed control, and the slave performs power balance depending on the speed loop of the master.)	0x001

Function code	Name	Description	Default
		<p>6: Master/slave mode 6 Used for master/slave height transmission. The master sends the measured height to the slave. (The height sent from the master can be viewed through P94.05; the height received by the slave can be viewed through P94.09.)</p> <p>7: Master/slave mode 7 Used for master speed control, slave torque control, and simultaneous brake closing/release control for master/slave with independent load Tens place: Slave start command source 0: Master 1: Determined by P00.01 Hundreds place: Whether to enable master/slave to send/receive data 0: Enable 1: Disable</p>	
P28.03	Slave speed gain	<p>It is a percentage of the master ramp frequency. When the master and slave are different in the DEC ratio: 0.0–500.0% When the master and slave are the same in the DEC ratio: 100.0%</p>	100.0%
P28.04	Slave torque gain	<p>It is a percentage of the set frequency of the master. When the master and slave are different in the motor power: 0.0–500.0% When the master and slave are the same in the motor power: 100.0%</p>	100.0%
P28.05	Frequency point for switching between speed mode and torque mode in master/slave mode 2	0.00–10.00Hz	5.00
P28.06	Number of slaves	0–15	1
P28.07	Master/slave transmission unit pulse ratio for position synchronization	0.00–100.00	1.00

Function code	Name	Description	Default
P28.08	Position synchronization deviation deadzone setting	0–50000 When the position difference is greater than P28.08, correction on the slave is valid.	50
P28.09	Position synchronization deviation threshold	0–50000 When the position difference is greater than P28.09, a master/slave position fault is reported.	1000
P28.10	Position synchronization regulator output limit	0.0–100.0%	5.0%
P28.11	Position synchronization pulse count reset method	0–1 0: Automatic During stop, the position synchronization pulse count is automatically reset. 1: Terminal based If the input terminal selects the position synchronization pulse count reset function, the pulse count is automatically reset when there is signal input.	0
P28.12	Position synchronization proportional coefficient	0.000–10.000	0.005
P28.13	Position synchronization integral time	0.01–80.00s	8.00s
P28.14	Position synchronization filtering time	0.00–10.00s	0.05s
P28.15	Enabling the slave speed deviation window	0–1 0: Disable 1: Enable When the slave adopts the torque control mode, the speed deviation monitoring function can be enabled.	0
P28.16	Slave positive speed deviation window upper	0.00–50.00Hz When the actual speed is higher than the given	5.00Hz

Function code	Name	Description	Default
	limit	speed, if the actual speed is higher than (Given speed + P28.16) and exceeds this upper limit, the speed has to be adjusted.	
P28.17	Slave negative speed deviation window lower limit	0.00–50.00Hz When the actual speed is lower than the given speed, if the actual speed is lower than (Given speed - P28.17) and the window lower limit, the speed has to be adjusted.	5.00Hz
P28.18	Slave rotation speed regulation coefficient Kb	0–50000 Applicable only in master/slave mode 5.	100
P28.19	Rotation speed difference compensation coefficient Kc (Reserved)	0–50000 Applicable only in master/slave mode 5, in which there are only one master and one slave.	100
P28.20	Rotation speed difference compensation target setting (Reserved)	0–2 0: No 1: Compensate both the master and slave 2: Compensate only the slave	0
P28.21	CAN slave torque offset	-100.0–100.0% Valid when the slave uses torque control.	0
P28.22	Timeout time of readiness for master to wait slave to release brake	0.0–30.00s	0

5.15.4 Master/slave switchover

1. Normal master/slave switchover work conditions

Application description: Both the master VFD and slave VFD drive a motor, but in certain cases, the master and slave must be switched over.

Commissioning description: Set an S (for example, S1) terminal of the master to 72, and an S (for example, S1) terminal of the slave to 71. Enable the S1 terminal of the master to make the master working as the slave. Enable the S1 terminal of the slave to make the slave working as the master. If different parameters need to be set for the master and slave, you can set P90.03.

Note: Refer to section 5.13.4 to set master and slave parameters. The following mainly describes the master/slave switchover.

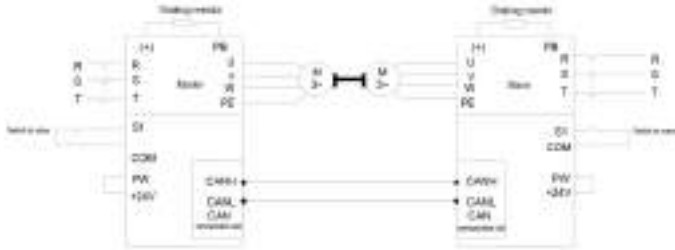

Master parameters:

Function code	Name	Description	Setting
P05.01	Function of S1	72: Switch to the slave	72
P90.03	Method for terminals to switch application macros	3: Switch from the master to the slave	3

Slave parameters:

Function code	Name	Description	Setting
P05.01	Function of S1	71: Switch to the master	71
P90.03	Method for terminals to switch application macros	4: Switch from the slave to the master	4

2. Motor and master/slave switchover work conditions

In the lifting job of port crane, VFD 1 as the master drives lifting motor 1, while VFD 2 as the slave drives lifting motor 2. After completing the lifting job, VFD 2 needs to drive the trolley motor independently. To do this, VFD 2 needs to:

- (1) Disable the master/slave mode and run independently.
- (2) Switch the motor from lifting motor 2 to trolley motor.
- (3) Switch motor and VFD parameters.

Note: The power supply switchover of lifting motor 2 and trolley must be controlled by the PLC.

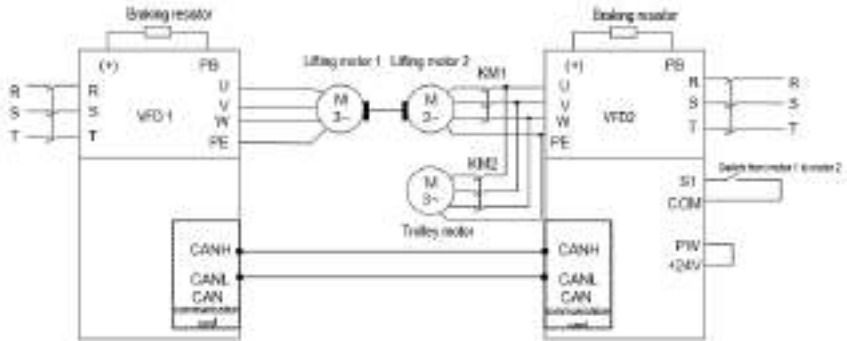

Commissioning procedure

1. Set P90.00=6 (User-defined macro 1) for VFD 2, set running parameters for lifting motor 2 according to the following table of user-defined application macro parameter settings, and note that A81.24=2 (Slave mode).
2. Set P90.01=7 (User-defined macro 2) for VFD 2, set the parameters for trolley motor according to the following table of user-defined application macro parameter settings, and note that A81.24=0 (Disable master/slave mode).
3. When the S1 terminal of VFD 2 is invalid, VFD 2 drives lifting motor 2 and VFD 1 drives lifting motor 1 to complete the lifting work. When the S2 terminal of VFD 2 is valid, VFD 2 independently drives the trolley motor to work.

Motor run status	VFD 1	VFD 2	KM1	KM2	VFD 2 Terminal S1	Lifting motor 1	Lifting motor 2	Trolley motor
Lifting run	Master P28.00=1	Slave A81.24=2 P28.00=2	Closed	Opened	Invalid	Run	Run	Stop
Trolley run	Master/ slave control is invalid. P28.00=0 Modified through the PLC	Master/ slave control is invalid. A82.24=0 (P28.00=0) Switched over through S1	Opened	Closed	Valid	Stop	Stop	Run Switched over through S1

Note: The value of P28.00 of VFD 1 needs to be modified through the PLC.

At the work conditions of trolley run, if it is difficult to change VFD 1 from master/slave control mode to non master/slave control mode (P28.00=0) through the PLC, you can set the hundreds place of P28.02 to 1 or use S terminal function 91 for VFD 1 to exit the master/slave mode.

Parameters of VFD 2

Function code	Name	Description	Setting
P05.01	Function of S1	35: Switch from motor 1 to motor 2	35
P90.00	Hoisting application macro setting	6: User-defined application macro 1 7: User-defined application macro 2	6
P90.01	Terminal-switched application macro setting		7
P90.03	Method for terminals to switch application macros	1: Switch from motor 1 to motor 2	1
A81.24	Master/slave mode	2: The local device is the slave.	2

5.15.5 User-defined application macros

You can enter user-defined application macro settings through P90.02.

Function code	Name	Description	Default
P90.02	User-defined application macro setting	0–3 0: None 1: Enter the settings of user-defined application macro 1 2: Enter the settings of user-defined application macro 2 3: Enter the settings of user-defined application macro 3	0

When P90.02=1, you will automatically enter A81.00–A81.46 to set related function codes.

When P90.02=2, you will automatically enter A82.00–A82.46 to set related function codes.

When P90.02=3, you will automatically enter A83.00–A83.46 to set related function codes.

Currently, there are 47 common function codes available for you to define macros. The three user-defined macro tables are the same. The following lists A81.00–A81.46.

User-defined function	Related function code	Name	Description	Setting range	Default
A81.00	P00.00	Speed control mode	0: Sensorless vector control (SVC) mode 0 1: Sensorless vector control (SVC) mode 1 2: V/F control 3: Closed-loop vector control mode	0–3	2
A81.01	P00.01	Channel of running commands	0: Keypad 1: Terminal 2: Communication	0–2	0
A81.02	P00.06	Setting channel of A frequency command	0: Keypad 1–14: See chapter 7. 15: Multi-step speed run	0–15	0
A81.03	P00.11	ACC time 1	0.0–3600.0s	0.0–3600.0	10.0s
A81.04	P00.12	DEC time 1	0.0–3600.0s	0.0–3600.0	10.0s
A81.05	P01.05	ACC/DEC mode	0: Linear 1: S curve	0–1	0
A81.06	P01.08	Stop mode	0: Decelerate to stop 1: Coast to stop	0–1	0
A81.07	P03.32	Enabling torque control	0: Disable 1: Enable	0–1	0
A81.08	P04.40	Enabling I/F mode for AM 1	0–1	0–1	0
A81.09	P04.41	Forward current setting in I/F mode for AM 1	0.0–200.0%	0.0–200.0%	120.0%
A81.10	P04.52	Reverse current setting in I/F mode for AM 1	0.0–200.0%	0.0–200.0%	120.0%
A81.11	P05.03	Function of S3	0: No function	0–95	0
A81.12	P05.04	Function of S4	1: Run forward 2: Run reversely 3–95: See chapter 7.	0–95	0
A81.13	P06.01	Y1 output	0: Invalid	0–70	0
A81.14	P06.03	RO1 output	1: Running	0–70	0
A81.15	P06.04	RO2 output	2: Running forward	0–70	0

User-defined function	Related function code	Name	Description	Setting range	Default
			3: Running reversely 4–70: See chapter 7.		
A81.16	P10.02	Multi-step speed 0	0.0–100.0%	0.0–100.0	0.0%
A81.17	P10.04	Multi-step speed 1	0.0–100.0%	0.0–100.0	0.0%
A81.18	P10.06	Multi-step speed 2	0.0–100.0%	0.0–100.0	0.0%
A81.19	P10.08	Multi-step speed 3	0.0–100.0%	0.0–100.0	0.0%
A81.20	P10.10	Multi-step speed 4	0.0–100.0%	0.0–100.0	0.0%
A81.21	P25.01	Function of S5	Same as P5	0–95	0
A81.22	P25.02	Function of S6		0–95	0
A81.23	P25.03	Function of S7		0–95	0
A81.24	P28.00	Master/slave mode	0: The master/slave mode is invalid. 1: The local device is the master. 2: The local device is the slave.	0–2	0
A81.25	P90.04	Enabling brake-oriented logic	0–1 0: The brake is controlled by an external controller. 1: The brake is controlled by the VFD.	0–1	0
A81.26	P90.05	Enabling forward torque for reverse-running start/stop	0x00–0x11 Ones place: indicates whether to enable forward torque for reverse-running start 0: Disable (The reverse-running start direction complies with the command.)	0x00–0x11	0x00

User-defined function	Related function code	Name	Description	Setting range	Default
			<p>1: Enable (The reverse-running start direction is always the forward-running direction.) Tens place: indicates whether to enable forward torque for reverse-running stop</p> <p>0: Disable (The reverse-running stop direction complies with the command.)</p> <p>1: Enable (The reverse-running stop direction is always the forward-running direction.)</p>		
A81.27	P90.06	Graded multi-step speed reference 0	0.0–100.0%	0.0–100.0	0.0%
A81.28	P90.07	Graded multi-step speed reference 1	0.0–100.0%	0.0–100.0	0.0%
A81.29	P90.08	Graded multi-step speed reference 2	0.0–100.0%	0.0–100.0	0.0%
A81.30	P90.09	Graded multi-step speed reference 3	0.0–100.0%	0.0–100.0	0.0%
A81.31	P90.10	Graded multi-step speed reference 4	0.0–100.0%	0.0–100.0	0.0%
A81.32	P90.12	Forward brake release current	0.0–200.0% (of the motor rated current)	0.0–200.0	0.0%
A81.33	P90.13	Reverse brake	0.0–200.0% (of the	0.0–200.0	0.0%

User-defined function	Related function code	Name	Description	Setting range	Default
		release current	motor rated current)		
A81.34	P90.14	Forward brake release torque	0.0–200.0% (of the motor rated torque)	0.0–200.0	0.0%
A81.35	P90.15	Reverse brake release torque	0.0–200.0% (of the motor rated torque)	0.0–200.0	0.0%
A81.36	P90.16	Forward brake release frequency	0.00–20.00Hz	0.00–20.00	3.00Hz
A81.37	P90.17	Reverse brake release frequency	0.00–20.00Hz	0.00–20.00	3.00Hz
A81.38	P90.18	Forward brake closing frequency	0.00–20.00Hz	0.00–20.00	3.00Hz
A81.39	P90.19	Reverse brake closing frequency	0.00–20.00Hz	0.00–20.00	3.00Hz
A81.40	P90.20	Delay before forward brake release	0.000–5.000s	0.000–5.000	0.300s
A81.41	P90.22	Delay after forward brake release	0.000–5.000s	0.000–5.000	0.300s
A81.42	P90.24	Delay before forward brake closing	0.000–5.000s	0.000–5.000	0.300s
A81.43	P90.26	Delay after forward brake closing	0.000–5.000s	0.000–5.000	0.300s
A81.44	P90.31	Enabling the monitoring on brake status	0–1 0: Disable 1: Enable the brake current monitoring (and brake feedback detection).	0–1	0
A81.45	P05.05	Function of HDIA	0: No function	0–95	0

User-defined function	Related function code	Name	Description	Setting range	Default
A81.46	P05.06	Function of HDIB	1: Run forward 2: Run reversely 3-95: See chapter 7.	0-95	0
A82.00-A82.46	With the same functions as A81.00-A81.46				
A83.00-A83.46	With the same functions as A81.00-A81.46				

5.16 Motor and macro switchover

5.16.1 Function description

The VFD supports the switchover between parameters of up to three motors. You can switch between motors through terminals. The method is as follows:

1. Set the ones place of P08.31 to 0 (using terminal control to switch between motors).
2. Select function 35 (switching motor 1 to motor 2) and function 88 (switching motor 1 to motor 3) for the S terminals to perform motor switchover.

In addition, motors can be switched through communication, only if you have set P08.31 to communication, and then the motor switchover command is given through communication.

In addition to motor switchover, up to two groups of control parameters can be switched over as follows:

1. Set P90.03 to 1 or 2, and select the motor that requires function parameter switchover. If motor 3 needs to switch function parameters, set P90.03 to 0.
2. Set P90.00 and P90.01. P90.00 corresponds to control parameters of motor 1, while P90.01 corresponds to control parameters of motor 2 or 3.

The following takes terminal-based switchover for example. (Note that you need to set P90.03=1 or 2 during communication-based switchover.)

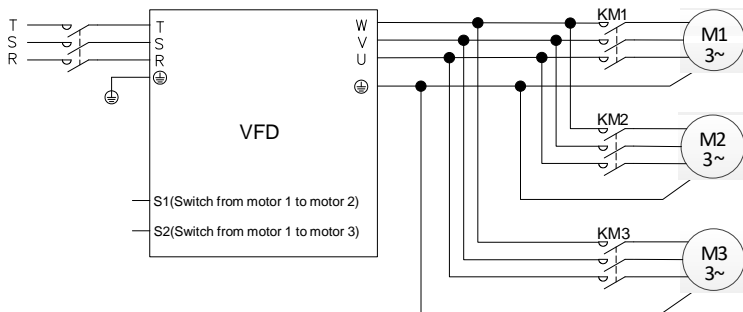

Note:

- Switching from motor 1 to motor 2 takes priority over switching from motor 1 to motor 3. That is, the signal for switching from motor 1 to motor 3 is detected only after no signal for switching from motor 1 to motor 2 is detected.
- The motor parameters for motor 2 are separate from those for motor 3. Group P12 and group P89 contain motor parameters for motor 2 and motor parameters for motor 3. However, if P90.03=0, three motors use similar parameters for control modes, such as VF and vector control parameters.

If P90.03=1, motor 1 and motor 3 use the same control parameters, while motor 2 uses independent run parameters.

If P90.03=2, motor 1 and motor 2 use the same control parameters, while motor 3 uses independent run parameters.
- During motor switching, the terminals to which application macros have assigned values cannot be used for switching. Otherwise, after the application macro is changed, the value is overwritten to the pre-assigned value, resulting in switching failure.

5.16.2 Description about switching from motor 2 to motor 3

The terminal input function does not contain the ability to switch from motor 2 to motor 3. To switch from motor 2 to motor 3, remove the signal for switching from motor 1 to motor 2, and then input the signal for switching from motor 1 to motor 3. If the signal for switching from motor 1 to motor 2 and switching from motor 1 to motor 3 are given simultaneously, the signal for switching from motor 1 to motor 2 is affected since the switching from motor 1 to motor 2 has higher priority (as mentioned earlier), and motor 2 is used automatically.

Example

If S1 is set to have terminal function 35 (for switching from motor 1 to motor 2) and S2 is set to have terminal function 88 (for switching from motor 1 to motor 3), there are four types of combination:

S1 status	S2 status	Present motor status	Contactor switch status
OFF	OFF	Switched to motor 1	KM1 closed, KM2 opened, KM3 opened
ON	OFF	Switched to motor 2	KM1 opened, KM2 closed, KM3 opened
OFF	ON	Switched to motor 3	KM1 opened, KM2 opened, KM3 closed
ON	ON	Switched to motor 2	KM1 opened, KM2 closed, KM3 opened

5.16.3 Motor and macro switchover parameters

Function code	Name	Description	Default
P08.31	Channel for switching between motor 1 and	0x00–0x14 LED Ones place: Switchover channel	0x00

Function code	Name	Description	Default
	motor 3	0: Terminal 1: Modbus/Modbus TCP communication 2: PROFIBUS/CANopen communication (same as the above) 3: Ethernet communication (same as the above) 4: EtherCAT/PROFINET/EtherNet IP communication 5: 216 communication LED tens place: indicates whether to enable switchover during running 0: Disable 1: Enable	
P90.00	Hoisting application macro setting	0–15 0: Common application mode	0
P90.01	Terminal-switched application macro setting	1: Lifting mode 1 (in open-loop vector control) 2: Lifting mode 2 (in closed-loop vector control) 3: Horizontal moving mode (in space voltage vector control) 4: Tower crane slewing mode 5: Conical motor application mode 6: User-defined application macro 1 7: User-defined application macro 2 8: User-defined application macro 3 9: Lifting mode 3 (in space voltage vector control) 10: Construction elevator mode 11: Closed-loop winching (for lifting in mineral wells and winches) 12: Open-loop winching (for lifting in mineral wells and winches) 13: Construction elevator mode 2 (for medium-speed elevator application) 14: Tower crane slewing without vortex in closed-loop vector control 15: Tower crane slewing without vortex in space voltage vector control	0
P90.02	User-defined	0–3	0

Function code	Name	Description	Default
	application macro setting	0: None 1: Enter the settings of user-defined application macro 1 2: Enter the settings of user-defined application macro 2 3: Enter the settings of user-defined application macro 3	
P90.03	Method for terminals to switch application macros	0–5 0: No switchover 1: Switch from motor 1 to motor 2 2: Switch from motor 1 to motor 3 3: Switch from the master to the slave 4: Switch from the slave to the master 5: Switch to SVC1 control (open-loop vector control 1)	0
P94.39	Present application macro	0–18	0

5.16.4 Terminal-based motor and macro switchover flowchart

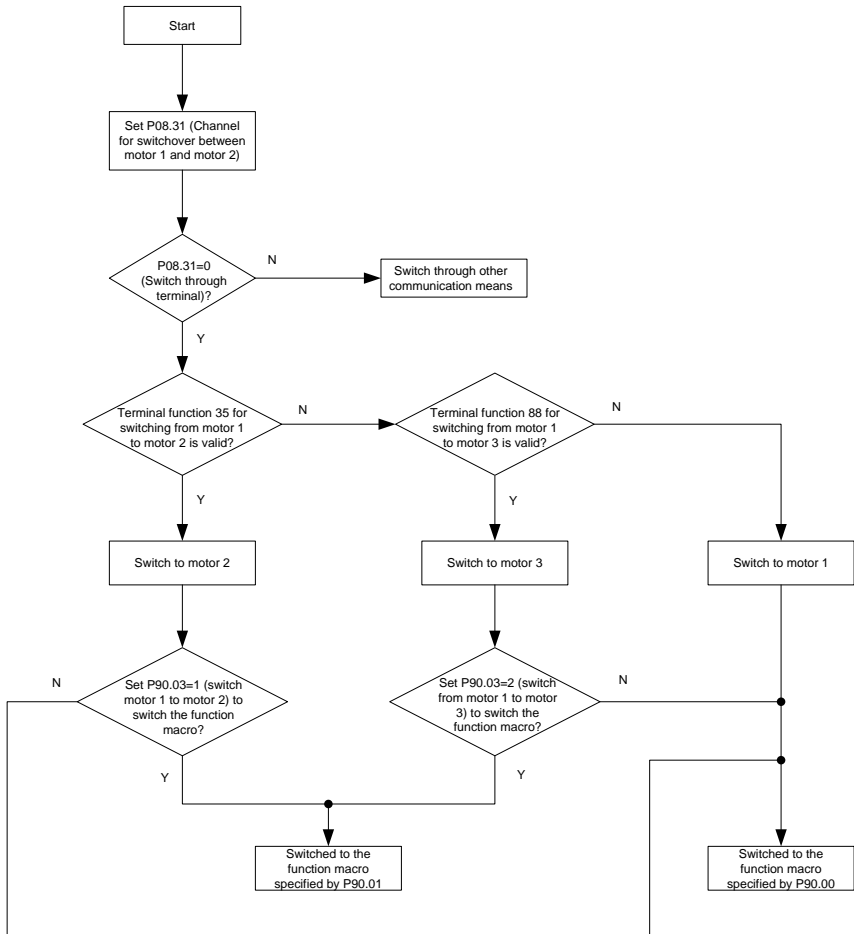

For user-defined application macros, see section 5.15.5 User-defined application macros.

5.16.5 Shortcut multi-motor speed control mode switchover

If you need to only switch over motor parameters and the control mode but not setting function parameters again during motor switchover, you do not need to switch the speed control mode through the application macro. In this case, you only need to set the speed control mode for motor 2 through P12.31 and that for motor 3 through P89.31.

Related parameters:

Function code	Name	Description	Default
P05.03	Function of S3	35: Switch from motor 1 to motor 2 88: Switch from motor 1 to motor 3	0
P08.31	Channel for switching between motor 1 and motor 2	0x00–0x14 Ones place: Switchover channel 0: Terminal 1: Modbus communication 2: PROFIBUS/CANopen/DeviceNet communication 3: Ethernet communication 4: EtherCAT/Profinet communication 5: 216 communication Tens place: indicates whether to enable switchover during running 0: Disable 1: Enable	0x00
P12.31	Speed control switchover mode of motor 2	0: No switchover, which indicates keeping consistant with P00.00 of motor 1 1: Switch to SVC1 2: Switch to VF mode 3: Switch to FVC	0
P89.31	Speed control mode switchover of motor 3	0: No switchover. This indicates that motor 3 uses P00.00 of motor 1. 1: Switch to SVC1 2: Switch to VF 3: Switch to FVC	0

5.17 Height measuring

5.17.1 Commissioning description

5.17.1.1 Internal measuring (Motor encoder)

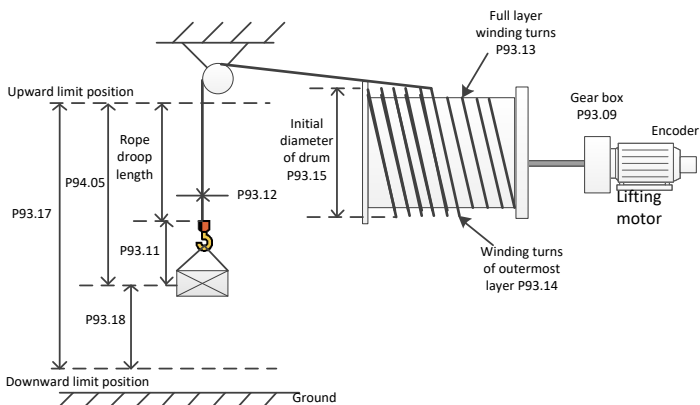

Figure 5-19 Internal measuring (motor encoder), using pulleys

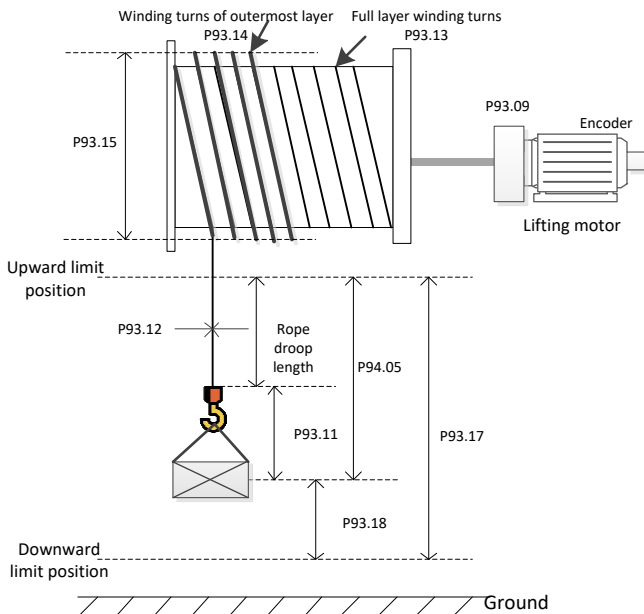

Figure 5-20 Internal measuring (motor encoder), without pulleys

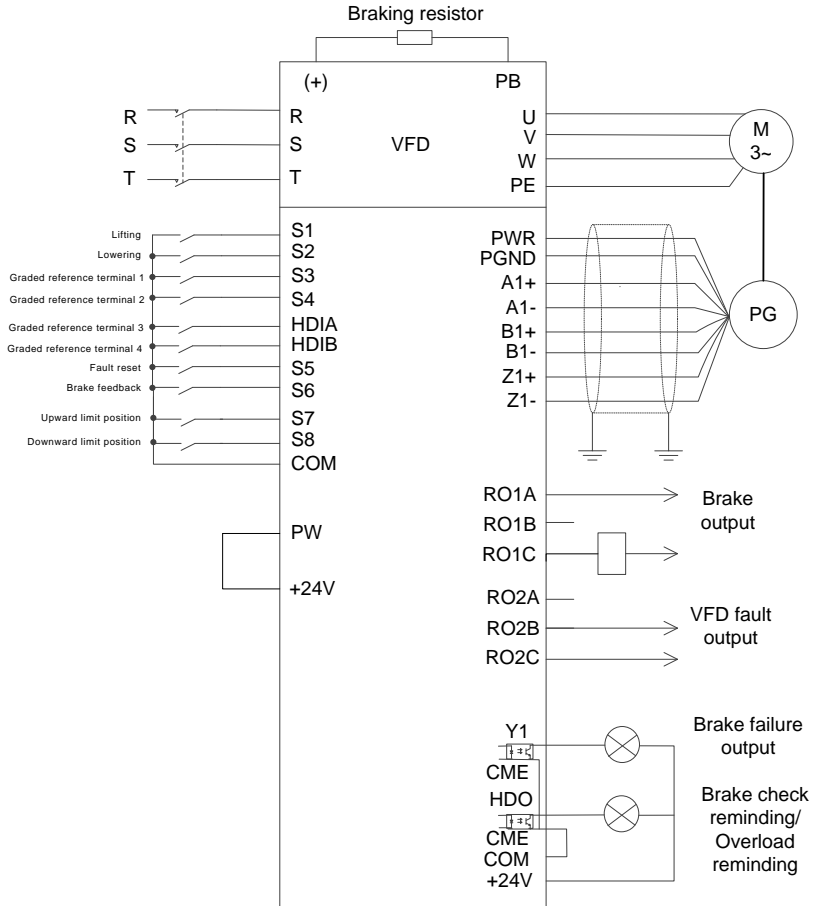

Figure 5-21 Wiring for internal measuring (motor encoder)

According to Figure 5-21, you need to set the suspension ratio P93.10 when pulleys are used, so that the height can be correctly measured in the closed-loop mode. Then the measured encoder pulse count is used to calculate the actual running distance of the motor. Before first running, the upward limit position must be calibrated. You need to use a PG card to connect the encoder (see A.6 for specific connection method), set P00.00=3 (Closed-loop control mode), P93.08=1 to enable internal measuring (motor encoder), and then set winding drum and cable parameters such as P93.09, P93.10, P93.11, P93.12, P93.13, P93.14 and P93.15.

The procedure for first running is as follows:

1. Set the upward limit terminal. For example, set P25.03=64, which indicates the S7 terminal is

used as for upper limit input.

2. Enable forward running (upward) and stop when the upward limit position is reached. Then perform calibration.
3. Record the values of P93.12 and P93.13 and reset P94.05, P94.06 and P94.07.
4. After the calibration, send the running command through the S2 terminal to run downward. Check the values of P94.05, P94.06, and P94.07.

If the downward limit position needs to be used as the reference point, the procedure for first running is as follows:

1. Set the upward and downward limit terminals S7 and S8. For example, set P25.03=64 and P25.04=65.
2. Enable forward running (upward) and stop when the upward limit position is reached. Then perform calibration.
3. Record the values of P93.12 and P93.13 and reset P94.05, P94.06 and P94.07.
4. The calibration is completed, which indicates proper running. P93.17 displays the height from the downward limit position to the upward limit position, P93.18 displays the height using the downward limit position as the reference point (the height is 0 at the downward limit position, the height is positive when it is above the downward limit position, the height is negative when it is under the downward limit position), and P94.05 displays the height using the upward limit position as the reference point (the height is 0 at the upward limit position, and only downward running is allowed when the upward limit position is reached, and P94.05 indicates the rope droop length when the upward limit position is not reached).

5.17.1.2 External measuring (HDI)

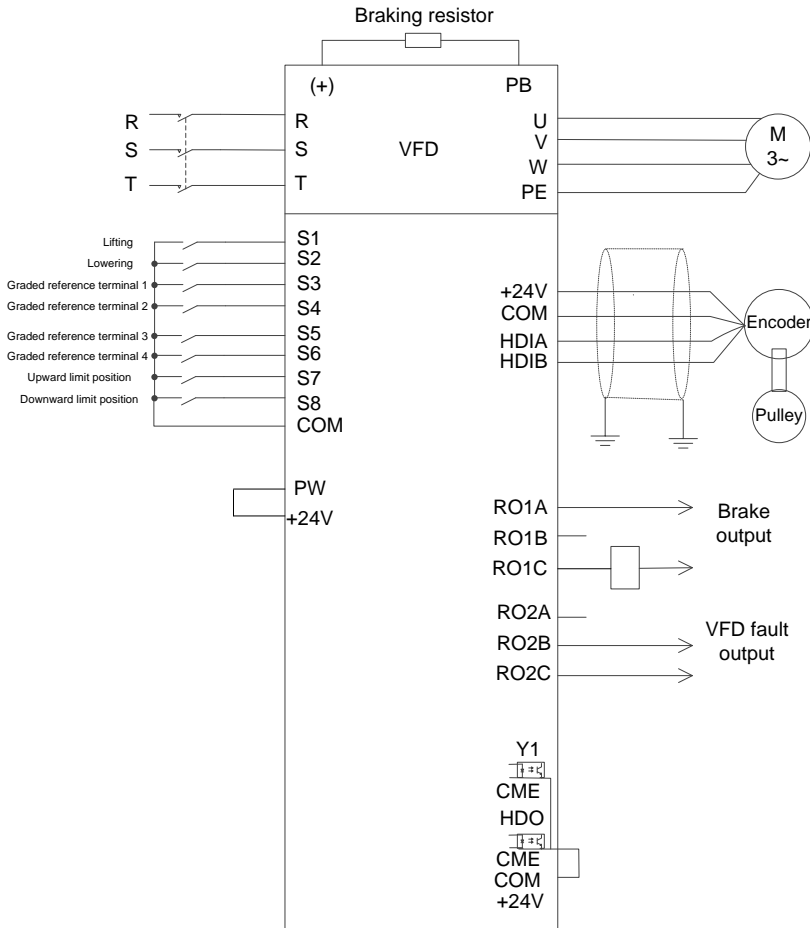

Figure 5-22 Wiring for external measuring (HDI) (In open-loop mode)

Note: During external measuring (HDI), only 24V incremental encoders can be used to measure pulley rotational speeds.

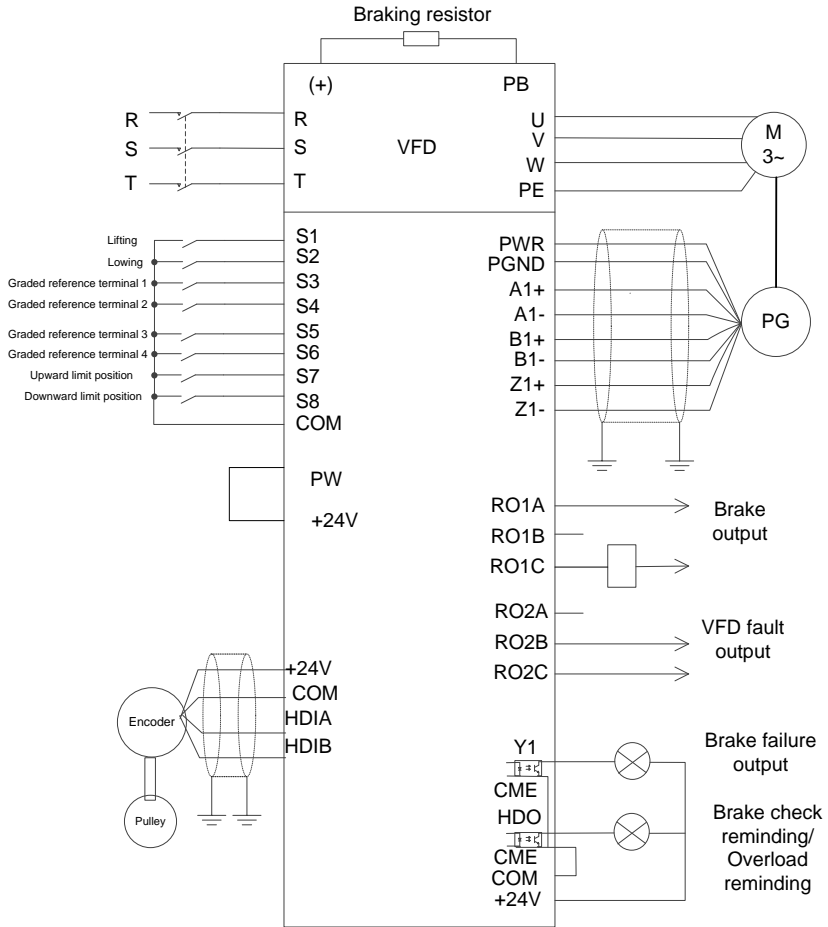

Figure 5-23 Wiring for external measuring (HDI) (In closed-loop mode)

Note: During external measuring (HDI), only 24V incremental encoders can be used to measure pulley rotational speeds.

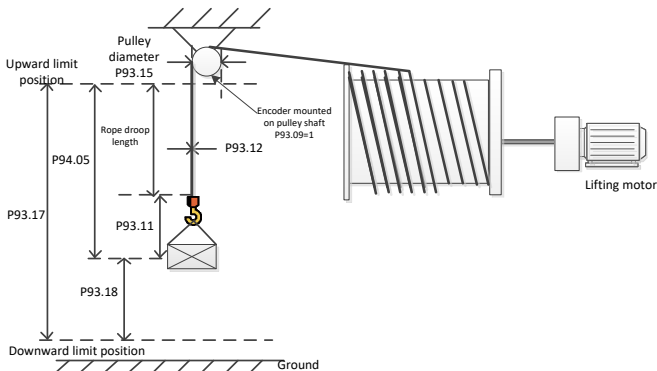

Figure 5-24 External measuring (HDI)

You need to set P05.38=2 and P05.44=2 to connect the encoder to HDIA and HDIB. In open/closed-loop mode, the encoder measures the encoder pulse count at the pulley side to calculate the actual cable running distance of pulley. Before first running, the upward limit position must be calibrated.

The procedure for first running is as follows:

1. Set the upward limit terminal. For example, set P25.03=64, which indicates the S7 terminal is used as for upper limit input.
2. Enable forward running (upward) and stop when the upward limit position is reached. Then perform calibration. Reset P94.05, P94.06 and P94.07.
3. After the calibration, send the running command through the S2 terminal to run downward. Check the values of P94.05, P94.06, and P94.07.

If the downward limit position needs to be used as the reference point, the procedure for first running is as follows:

1. Set the upward and downward limit terminals S7 and S8. For example, set P25.03=64 and P25.04=65.
2. Enable forward running (upward) and stop when the upward limit position is reached. Then perform calibration. Reset P94.05, P94.06 and P94.07.
3. Send the running command through the S2 terminal to run downward only if the downward limit terminal S8 is valid. P93.17 displays the height from the upward limit position to the downward limit position and P93.18 displays 0.
4. The calibration is completed, which indicates proper running. P93.17 displays the height from the downward limit position to the upward limit position, P93.18 displays the height using the downward limit position as the reference point (the height is 0 at the downward limit position, the

height is positive when it is above the downward limit position, the height is negative when it is under the downward limit position), and P94.05 displays the height using the upward limit position as the reference point (the height is 0 at the upward limit position, and only downward running is allowed when the upward limit position is reached, and P94.05 indicates the rope droop length when the upward limit position is not reached).

Note: During external measuring (HDI) (for the encoder to measuring the pulley rotational speed), P93.09 indicates the transmission ratio between the encoder and pulley, while P93.15 indicates the pulley diameter.

5.17.2 Parameters about height measuring

Table 5-7 Parameters about internal measuring (motor encoder)

Function code	Name	Description	Setting
P00.00	Speed control mode	0: Sensorless vector control (SVC) mode 0 1: Sensorless vector control (SVC) mode 1 2: Space voltage vector control mode 3: Closed-loop vector control mode Note: Before using a vector control mode (0, 1, or 3), enable the VFD to perform motor parameter autotuning first.	3
P00.01	Channel of running commands	0: Keypad 1: Terminal 2: Communication	1
P05.01	Function of S1	1: Run forward	1
P05.02	Function of S2	2: Run reversely	2
P25.03	Function of S7	64: Limit of forward run (upward)	64
P25.04	Function of S8	65: Limit of reverse run (downward)	65
P20.15	Speed measurement mode	0: Measuring speed by PG card/Measuring height locally	0
P93.08	Enabling height measuring	0-1 0: Disable 1: Enable internal measuring (motor encoder) (In closed-loop mode, the encoder measures the speed and height.) 2: Enable external measuring (HDI) (In open- and closed-loop modes, the pulley encoder measures the height.) Note: When P93.08=2, P20.15=0 indicates HDI measuring the height.	1
P93.09	Mechanical	0.01-300.00	10.00

Function code	Name	Description	Setting
	transmission ratio		
P93.10	Suspension ratio	1–4	1
P93.11	Rope length compensation	0.00–50.00m	0.00
P93.12	Cable diameter	0.1–100.0m	10.0mm
P93.13	Per-layer turns of drum winding	1–200	30
P93.14	Initial turns of drum winding	0–P93.11 (Per-layer turns of drum winding)	0
P93.15	Initial diameter of drum diameter	100.0–2000.0mm (Max. drum diameter in upward limit, including cable thickness)	600.0mm
P93.16	Enabling upward/downward limit position check	0x00–0x11 Ones place: 0: The upward limit position is not reached. 1: The upward limit position is reached. Tens place: 0: The downward limit position is not reached. 1: The downward limit position is reached. Note: Used for height measuring without upward or downward limit device.	0x00
Height status check			
P93.17	Total height measured	0.00–655.35m (Total height measured from the upward limit position to the downward limit position)	0.00m
P93.18	Measured height 1	-50.00m–655.35m (Using the downward limit position as the reference point)	0.00m
P94.05	Measured height	0.00–655.35m (Hook lowering distance using the upward limit position as the reference point)	0.00m
P94.06	Hight bits of measured height count value	0–65535	0
P94.07	Low bits of measured height count value	0–65535	0

Table 5-8 Parameters about external measuring (HDI)

Function code	Name	Description	Setting
P00.00	Speed control mode	0: Sensorless vector control (SVC) mode 0 1: Sensorless vector control (SVC) mode 1 2: Space voltage vector control mode 3: Closed-loop vector control mode Note: Before using a vector control mode (0, 1, or 3), enable the VFD to perform motor parameter autotuning first.	2
P00.01	Channel of running commands	0: Keypad 1: Terminal 2: Communication	1
P05.00	HDI input type	0x00–0x11 Ones place: HDIA input type 0: HDIA is high-speed pulse input 1: HDIA is digital input Tens place: HDIB input type 0: HDIB is high-speed pulse input 1: HDIB is digital input	0x00
P05.01	Function of S1	1: Run forward	1
P05.02	Function of S2	2: Run reversely	2
P20.15	Speed measurement mode	0: Measuring speed by PG card/Measuring height locally	0
P25.03	Function of S7	64: Limit of forward run (upward)	64
P25.04	Function of S8	65: Limit of reverse run (downward)	65
P05.38	HDIA high-speed pulse input function selection	2: Input set through encoder, used together with HDIB	2
P05.44	HDIB high-speed pulse input function selection	2: Input set through encoder, used together with HDIA	2
P93.08	Enabling height measuring	0–1 0: Disable 1: Enable internal measuring (motor encoder) (In closed-loop mode, the encoder measures the speed and height.) 2: Enable external measuring (HDI) (In open- and closed-loop modes, the pulley encoder measures the height.)	2

Function code	Name	Description	Setting
P93.09	Mechanical transmission ratio	0.01–300.00	1.00
P93.10	Suspension ratio	1–4	1
P93.11	Rope length compensation	0.00–50.00m	0.00
P93.12	Cable diameter	0.1–100.0m	10.0mm
P93.15	Pulley diameter	100.0–2000.0mm	600.0mm
Height status check			
P93.17	Total height measured	0.00–655.35m (Total height measured from the upward limit position to the downward limit position)	0.00m
P93.18	Measured height 1	-50.00m–655.35m (Using the downward limit position as the reference point)	0.00m
P94.05	Measured height	0.00–655.35m (hook lowering distance)	0.00m
P94.06	Hight bits of measured height count value	0–65535	0
P94.07	Low bits of measured height count value	0–65535	0

5.18 Temperature measuring

5.18.1 Using PT100/PT1000

(1) Through an expansion card



Figure 5-25 PT100/PT1000 measuring temperature through an expansion card

Procedure

1. Connect the expansion card EC-IO502-00 to PT100/PT1000.
2. Set P92.12=0x01 to enable PT100 to detect temperature or set P92.12=0x10 to enable PT1000 to detect temperature. In addition, set P92.13=0x01 to enable PT100 to detect disconnection or set P92.13=0x10 to enable PT1000 to detect disconnection.
3. Check whether P94.16 (PT100 present temperature) and P94.17 (PT100 present digital) are

correct, or check whether P94.18 (PT1000 present temperature) and P94.19 (PT1000 present digital) are correct.

Function parameter settings

Function code	Name	Description	Setting
P92.12	Enabling PT100/PT1000 temperature detection	Ones place: whether to enable PT100 temperature detection 0: Disable 1: Enable Tens place: whether to enable PT1000 temperature detection 0: Disable 1: Enable	0x01 or 0x10
P92.13	Enabling PT100/PT1000 disconnection detection	Ones place: whether to enable PT100 disconnection detection 0: Disable 1: Enable Hundreds place: whether to enable PT1000 disconnection detection 0: Disable 1: Enable	0x01
P92.14	PT100 overtemperature protection point	0.0–150.0°C	120.0°C
P92.15	PT100 overtemperature pre-alarm point	0.0–150.0°C	100.0°C
P92.16	PT1000 overtemperature protection point	0.0–150.0°C	120.0°C
P92.17	PT1000 overtemperature pre-alarm point	0.0–150.0°C	100.0°C
P92.18	PT100/PT1000 calibrated temperature upper limit	50.0–150.0°C	120.0°C
P92.19	PT100/PT1000 calibrated	-20.0–50.0°C	20.0°C

Function code	Name	Description	Setting
	temperature lower limit		
P92.20	Digital of PT100/PT1000 calibrated temperature	0–4 0: Normal detection 1: PT100 lower limit digital calibration autotuning 2: PT100 upper limit digital calibration autotuning 3: PT1000 lower limit digital calibration autotuning 4: PT1000 upper limit digital calibration autotuning After autotuning is completed, the function code is automatically cleared, and the calibration value is automatically saved to the I/O card.	0

(2) Through an AI terminal

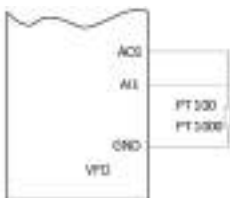

Figure 5-26 Wiring between analog terminals and PT100/PT1000

Note: Turn SW2 on the control board to "I" for current output.

Procedure

1. Connect PT100/PT1000 according to the figure.
2. Set P92.22=1 to select PT100, or set P92.22=2 to select PT1000.
3. Set P92.23 (AI detected motor overtemperature protection threshold) and P92.24 (AI detected motor overtemperature alarm threshold).
4. Check whether P94.20 (AI detected motor temperature) is correct.

Function parameter settings

Function code	Name	Description	Setting
P92.22	Type of sensor for AI to detect motor temperature	1: PT100 2: PT1000	1 or 2
P92.23	AI detected motor overtemperature	0.0–200.0°C When P94.20 is greater than P92.24, the motor	110.0

Function code	Name	Description	Setting
	protection threshold	overtemperature (OT) fault is reported.	
P92.24	AI detected motor overtemperature pre-alarm threshold	0.0–200.0°C When P94.20 is greater than P92.24, the A-Aot alarm is reported, but the VFD still runs.	90.0
P94.20	AI detected motor temperature	-20.0–200.0°C	0.0°C

5.18.2 Using KTY84

Through an AI terminal

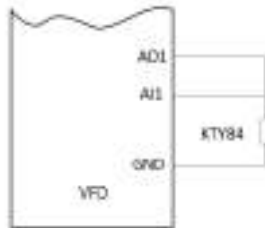

Figure 5-27 Wiring between analog terminals and KTY84

Note: Turn SW2 on the control board to "I" for current output.

Procedure

1. Connect KTY84 according to the figure.
2. Set set P92.22=3 to select KTY84.
3. Set P92.23 (AI detected motor overtemperature protection threshold) and P92.24 (AI detected motor overtemperature alarm threshold).
4. Check whether P94.20 (AI detected motor temperature) is correct.

Function parameter settings

Function code	Name	Description	Setting
P92.22	Type of sensor for AI to detect motor temperature	3: KTY84	3
P92.23	AI detected motor overtemperature protection threshold	0.0–200.0°C When P94.20 is greater than P92.24, the motor overtemperature (OT) fault is reported.	110.0

Function code	Name	Description	Setting
P92.24	AI detected motor overtemperature pre-alarm threshold	0.0–200.0°C When P94.20 is greater than P92.24, the A-Aot alarm is reported, but the VFD still runs.	90.0
P94.20	AI detected motor temperature	-20.0–200.0°C	0.0°C

5.18.3 Using PTC

(1) Through an expansion card

1. You can connect external PTC signal to terminal S8 through the expansion card EC-IO501-00, and set the terminal function to 86 (PTC overtemperature signal is valid).

Note: This function supports only terminal S8, the connected PTC acts at 2.5kΩ and supports only dry-contact shared COM input.

2. You can set P92.21 to determine whether the VFD reports the alarm A-Ptc to run normally or report PtcE to stop when the PTC overtemperature switch signal is valid.

Function parameter settings

Function code	Name	Description	Setting
P92.21	PTC overtemperature selection	0–1 0: The PTC function is enabled through terminal selection. When the PTC overtemperature alarm A-Ptc is reported, this cannot terminate normal running. 1: The PTC function is enabled through terminal selection. When the PTC overtemperature fault PtcE is reported, this results in stop.	0
P25.04	Function of S8	86: PTC overtemperature valid signal	86

(2) Through terminal AI1

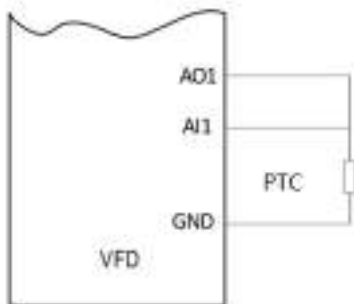

Figure 5-28 Wiring between PTC and analog terminals

Note: You need to turn SW2 on the control board to the "I" position (indicating current). Only AI1 and AO1 are supported for PTC to measure temperature.

Procedure

1. Connect to PTC according to the figure.
2. Set P92.22=4 to set the temperature sensor type to PTC.
3. Set P06.23 (often using the default value).
4. Set P06.24 and P06.25 according to the selected PTC model resistance and temperature curve.
5. Check whether the actual PTC resistance is correct.

Function code	Name	Description	Setting
P92.22	Type of sensor for AI to detect motor temperature	4: PTC (supporting only AI1)	4
P06.23	Output current setting of AO1	0.000–20.000mA	4.000
P06.24	PTC resistance alarm threshold	0–60000Ω When P06.26 is greater than P06.24, the VFD reports the alarm A-Aot and runs normally.	750
P06.25	PTC resistance alarm recovery threshold	0–60000Ω When P06.26 is less than P06.25, the alarm A-Aot is cleared.	150
P06.26	Actual PTC resistance	0–60000Ω	

6 Basic operation guidelines

6.1 What this chapter contains

This chapter instructs you how to use the VFD keypad and commission the VFD common functions.

6.2 Keypad introduction

The keypad is used to control the VFD, read status data, and set parameters.

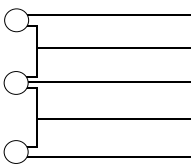









Figure 6-1 Keypad

Note:

- The LED keypad is a standard part for the VFD. In addition, if you need, the LCD keypad (an optional part) can be provided. The LCD keypad supports multiple languages, parameter copying function, and ten-row high-definition display. The installation size of the LCD is compatible with the LED keypad.
- If you need install the keypad externally (that is, on another position rather than on the VFD), you can use M3 screws to fix the keypad, or you can use the keypad installation bracket to install the keypad. The installation bracket is an optional part for 380V 1.5–30kW and 500V 4–18.5kW VFD models, but it is a standard part for 380V 37–500kW, 500V 22–75kW, and 660V VFD models.

No.	Name	Description	
1	Status indicator	RUN/TUNE	VFD running status indicator. LED off: The VFD is stopped. LED blinking: The VFD is autotuning parameters. LED on: The VFD is running.
		FWD/REV	Forward or reverse running indicator. LED off: The VFD is running forward. LED on: The VFD is running reversely.
		LOCAL/REMOT	Indicates whether the VFD is controlled

No.	Name	Description					
			through the keypad, terminals, or communication. Off: The VFD is controlled through the keypad. Blinking: The VFD is controlled through terminals. On: The VFD is controlled through remote communication.				
		TRIP	Fault indicator LED on: in fault state LED off: in normal state LED blinking: in pre-alarm state				
2	Unit indicator	Unit displayed currently					
			Hz	Frequency unit			
			RPM	Rotation speed unit			
			A	Current unit			
			%	Percentage			
		V	Voltage unit				
3	Digital display zone	Five-digit LED displays various monitoring data and alarm codes such as the frequency setting and output frequency.					
		Display	Means	Display	Means	Display	Means
		0	0	1	1	2	2
		3	3	4	4	5	5
		6	6	7	7	8	8
		9	9	A.	A	b.	B
		C.	C	d	d	E.	E
		F.	F	H.	H	I.	I
		L.	L	n.	N	n	n
		O	o	P.	P	r	r
		S.	S	t	t	U.	U
		u	v	.	.	-	-
4	Digital potentiometer	For frequency regulation. For details, see the description of P08.42.					
5	Keys		Programming key	Press it to enter or exit level-1 menus or delete a parameter.			
			Confirmation key	Press it to enter menus in cascading mode or confirm the setting of a parameter.			

No.	Name	Description		
			UP Up key	Press it to increase data or move upward.
			Down key	Press it to decrease data or move downward.
			Right-shifting key	Press it to select display parameters rightward in the interface for the VFD in stopped or running state or to select digits to change during parameter setting.
			Run key	Press it to run the VFD when using the keypad for control.
			Stop/ Reset key	Press it to stop the VFD that is running. The function of this key is restricted by P07.04. In fault alarm state, this key can be used for reset in any control modes.
			Multifunction shortcut key	The function is determined by P07.02.

6.3 Keypad display

The VFD keypad displays information such as the stopped-state parameters, running-state parameters, and fault status, and allows you to modify function codes.

6.3.1 Displaying fault information

After detecting a fault signal, the VFD enters the fault alarm state immediately, the fault code blinks on the keypad, and the **TRIP** indicator is on. You can perform fault reset by using the **STOP/RST** key, control terminals, or communication commands.

If the fault persists, the fault code is continuously displayed.

6.3.2 Editing function codes

You can press the **PRG/ESC** key to enter the editing mode in stopped, running, or fault alarm state (if a user password is used, see the description of P07.00). The editing mode contains two levels of menus in the following sequence: Function code group or function code number → Function code setting. You can press the **DATA/ENT** key to enter the function parameter display interface. In the function parameter display interface, you can press the **DATA/ENT** key to save parameter settings or press the **PRG/ESC** key to exit the parameter display interface.

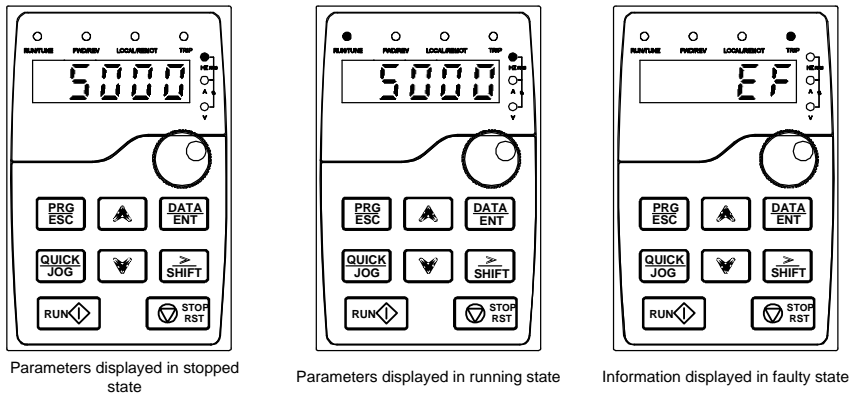

Figure 6-2 Status display

6.4 Operation procedure

You can operate the VFD by using the keypad. For details about function code descriptions, see the function code list.

6.4.1 Modifying function codes

The VFD provides three levels of menus, including:

- Function code group number (level-1 menu)
- Function code number (level-2 menu)
- Function code setting (level-3 menu)

Note: When performing operations on the level-3 menu, you can press the **PRG/ESC** or **DATA/ENT** key to return to the level-2 menu. If you press the **DATA/ENT** key, the set value of the parameter is saved to the control board first, and then the level-2 menu is returned, displaying the next function code. If you press the **PRG/ESC** key, the level-2 menu is returned directly, without saving the set value of the parameter, and the current function code is displayed.

If you enter the level-3 menu but the parameter does not have a digit blinking, the parameter cannot be modified due to either of the following reasons:

- It is read only. Read-only parameters include actual detection parameters and running record parameters.
- It cannot be modified in running state and can be modified only in stopped state.

Example: Change the value of P00.01 from 0 to 1.

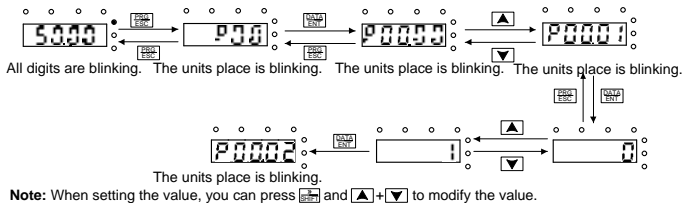

Figure 6-3 Modifying a parameter

6.4.2 Setting a password for the VFD

The VFD provides the user password protection function. When you set P07.00 to a non-zero value, the value is the user password. If password protection is enabled, "0.0.0.0.0" is displayed when you press the **[PRG/ESC]** key again to enter the function code editing interface. You need to enter the correct user password to enter the interface.

To disable the password protection function, you need only to set P07.00 to 0.

After you exit the function code editing interface, the password protection function is enabled within 1 minute. If password protection is enabled, "0.0.0.0.0" is displayed when you press the **[PRG/ESC]** key again to enter the function code editing interface. You need to enter the correct user password to enter the interface.

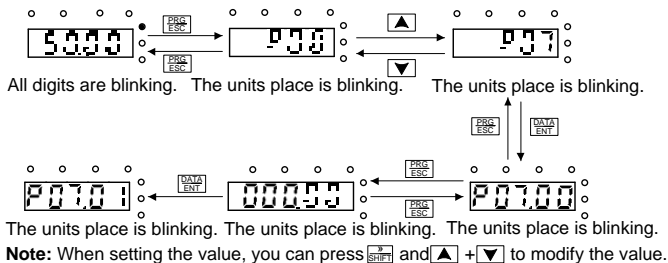

Figure 6-4 Setting a password

6.4.3 Viewing VFD status

The VFD provides group P17 for status viewing. You can enter group P17 for viewing.

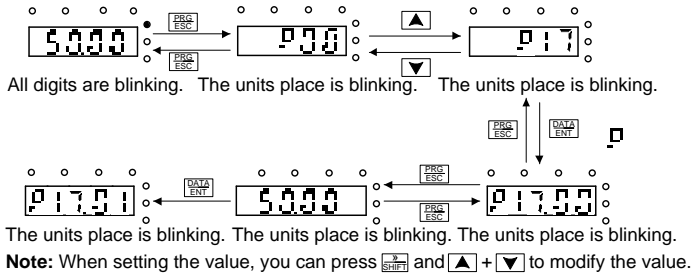



Figure 6-5 Viewing a parameter

6.5 Basic operation description

6.5.1 What this section describes

This section introduces the function modules inside the VFD.

	<ul style="list-style-type: none"> ◇ Ensure that all terminals have been securely connected. ◇ Ensure that the motor power matches the VFD power.
---	---

6.5.2 Common commissioning procedure

6.5.3 Vector control

6.5.4 Space voltage vector control mode

6.5.5 Torque control

6.5.6 Motor parameters

6.5.7 Start/stop control

6.5.8 Frequency setting

6.5.9 Analog input

6.5.10 Analog output

6.5.11 Digital input

6.5.12 Digital output

6.5.13 Simple PLC

For details about sections 6.5.2 to 6.5.13, see the *Goodrive350 Series High-performance Multifunction VFD Operation Manual*.

6.5.14 Multi-step speed running

Set the parameters used in multi-step speed running. The VFD can set 16-step speeds, which are selectable by multi-step speed terminals 1–4, corresponding to multi-step speed 0 to multi-step speed 15.

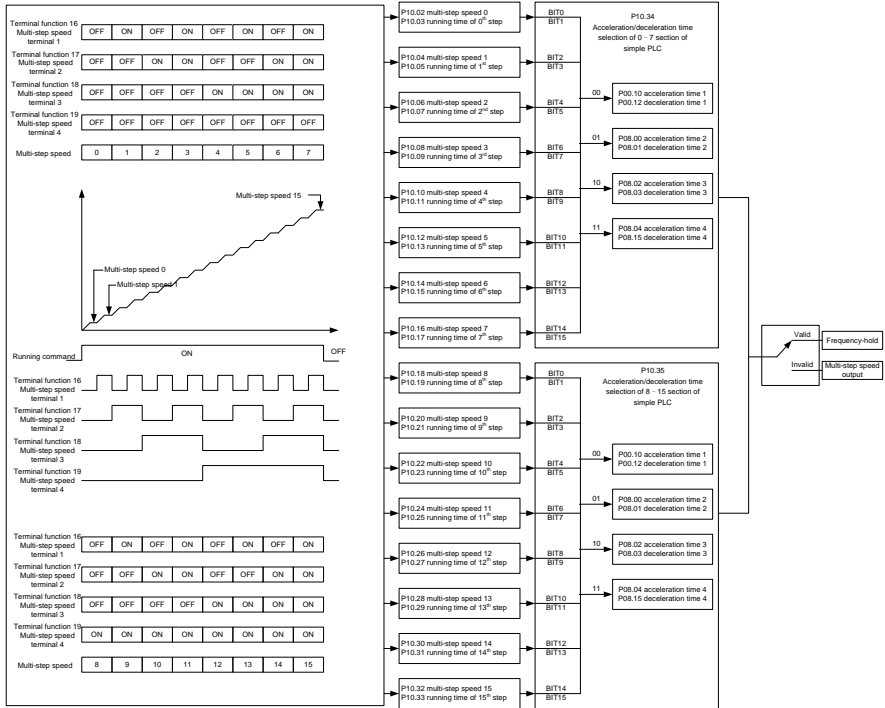

Related parameter list:

Function code	Name	Description	Default
P05.01–P05.06	Digital input function selection	16: Multi-step speed terminal 1 17: Multi-step speed terminal 2 18: Multi-step speed terminal 3 19: Multi-step speed terminal 4 20: Pause multi-step speed running	
P10.02	Multi-step speed 0	-100.0–100.0%	0.0%
P10.03	Running time of step 0	0.0–6553.5s (min)	0.0s
P10.04	Multi-step speed 1	-100.0–100.0%	0.0%
P10.05	Running time of step 1	0.0–6553.5s (min)	0.0s
P10.06	Multi-step speed 2	-100.0–100.0%	0.0%
P10.07	Running time of step 2	0.0–6553.5s (min)	0.0s
P10.08	Multi-step speed 3	-100.0–100.0%	0.0%

Function code	Name	Description	Default
P10.09	Running time of step 3	0.0–6553.5s (min)	0.0s
P10.10	Multi-step speed 4	-100.0–100.0%	0.0%
P10.11	Running time of step 4	0.0–6553.5s (min)	0.0s
P10.12	Multi-step speed 5	-100.0–100.0%	0.0%
P10.13	Running time of step 5	0.0–6553.5s (min)	0.0s
P10.14	Multi-step speed 6	-100.0–100.0%	0.0%
P10.15	Running time of step 6	0.0–6553.5s (min)	0.0s
P10.16	Multi-step speed 7	-100.0–100.0%	0.0%
P10.17	Running time of step 7	0.0–6553.5s (min)	0.0s
P10.18	Multi-step speed 8	-100.0–100.0%	0.0%
P10.19	Running time of step 8	0.0–6553.5s (min)	0.0s
P10.20	Multi-step speed 9	-100.0–100.0%	0.0%
P10.21	Running time of step 9	0.0–6553.5s (min)	0.0s
P10.22	Multi-step speed 10	-100.0–100.0%	0.0%
P10.23	Running time of step 10	0.0–6553.5s (min)	0.0s
P10.24	Multi-step speed 11	-100.0–100.0%	0.0%
P10.25	Running time of step 11	0.0–6553.5s (min)	0.0s
P10.26	Multi-step speed 12	-100.0–100.0%	0.0%
P10.27	Running time of step 12	0.0–6553.5s (min)	0.0s
P10.28	Multi-step speed 13	-100.0–100.0%	0.0%
P10.29	Running time of step 13	0.0–6553.5s (min)	0.0s
P10.30	Multi-step speed 14	-100.0–100.0%	0.0%
P10.31	Running time of step 14	0.0–6553.5s (min)	0.0s
P10.32	Multi-step speed 15	-100.0–100.0%	0.0%
P10.33	Running time of step 15	0.0–6553.5s (min)	0.0s
P10.34	ACC/DEC time of steps 0–7 of simple PLC	0x0000–0xFFFF	0000
P10.35	ACC/DEC time of steps 8–15 of simple PLC	0x0000–0xFFFF	0000
P17.27	Simple PLC and actual step of multi-step speed	0–15	0

6.5.15 Graded multi-step speed reference

Graded reference is a speed reference method for hoisting applications. Graded reference supports

the graded operating lever mode and graded remote-control mode. Graded reference can implement 6-step speeds by combing the five graded multi-step reference terminals. The combination methods are as follows:

Graded reference terminal 1	Graded reference terminal 2	Graded reference terminal 3	Graded reference terminal 4	Graded reference terminal 5	Speed setting	Function code
OFF	OFF	OFF	OFF	OFF	Graded multi-step speed reference 0	P90.06
NO	OFF	OFF	OFF	OFF	Graded multi-step speed reference 1	P90.07
NO	NO	OFF	OFF	OFF	Graded multi-step speed reference 2	P90.08
NO	NO	NO	OFF	OFF	Graded multi-step speed reference 3	P90.09
NO	NO	NO	NO	OFF	Graded multi-step speed reference 4	P90.10
NO	NO	NO	NO	NO	Graded multi-step speed reference 5	P90.11

Related parameter list:

Function code	Name	Description	Default
P05.01–P05.06 I/O expansion card P25.01–P25.08	Digital input function selection	77: Graded reference terminal 1 78: Graded reference terminal 2 79: Graded reference terminal 3 80: Graded reference terminal 4 81: Graded reference terminal 5	
P90.06	Graded multi-step speed reference 0	-100.0–100.0%, relative to P00.03	0.0%
P90.07	Graded multi-step speed reference 1	-100.0–100.0%, relative to P00.03	0.0%
P90.08	Graded multi-step speed reference 2	-100.0–100.0%, relative to P00.03	0.0%
P90.09	Graded multi-step speed reference 3	-100.0–100.0%, relative to P00.03	0.0%
P90.10	Graded multi-step speed reference 4	-100.0–100.0%, relative to P00.03	0.0%
P90.11	Graded multi-step speed reference 5	-100.0–100.0%, relative to P00.03	0.0%

Note: The multi-step settings of a higher grade can be closed only after the multi-step settings of all lower grades are closed.

6.5.16 Local encoder input

6.5.17 Commissioning procedures for position control and spindle positioning

6.5.18 Fault handling

For details about sections 6.5.16 to 6.5.18, see the *Goodrive350 Series High-performance Multifunction VFD Operation Manual*.

7 Function parameter list

7.1 What this chapter contains

This chapter lists all the function codes and corresponding description of each function code.

7.2 Function parameter list

The function parameters of the VFD are divided into groups by function. Among the function parameter groups, groups P85–P94 are hoisting function groups, P98 is the analog input and output calibration group, while P99 contains the factory function parameters, which are user inaccessible. Each group includes several function codes (each function code identifies a function parameter). A three-level menu style is applied to function codes. For example, "[P08.08](#)" indicates the 8th function code in P08.

The function group numbers correspond to the level-1 menus, the function codes correspond to the level-2 menus, and the function parameters correspond to the level-3 menus.

1. The content of the function code table is as follows:

Column 1 "Function code ": Code of the function group and parameter

Column 2 "Name": Full name of the function parameter

Column 3 "Description": Detailed description of the function parameter

Column 4 "Default": Initial value set in factory

Column 5 "Modify": Whether the parameter can be modified, and conditions for the modification

"○" indicates that the value of the parameter can be modified when the VFD is in stopped or running state.

"◎" indicates that the value of the parameter cannot be modified when the VFD is in running state.

"●" indicates that the value of the parameter is detected and recorded, and cannot be modified.

(The VFD automatically checks and constrains the modification of parameters, which helps prevent incorrect modifications.)

2. The parameters adopt the decimal system (DEC). If the hexadecimal system is adopted, all bits are mutually independent on data during parameter editing, and the setting ranges at some bits can be hexadecimal (0–F).
3. "Default" indicates the factory setting of the function parameter. If the value of the parameter is detected or recorded, the value cannot be restored to the factory setting.
4. To better protect parameters, the VFD provides the password protection function. After a password is set (that is, [P07.00](#) is set to a non-zero value), "0.0.0.0.0" is displayed when you press the **PRG/ESC** key to enter the function code editing interface. You need to enter the correct user password to enter the interface. For the factory parameters, you need to enter the correct factory password to enter the interface. (You are not advised to modify the factory

parameters. Incorrect parameter setting may cause operation exceptions or even damage to the VFD.) If password protection is not in locked state, you can change the password any time. You can set [P07.00](#) to 0 to cancel the user password. When [P07.00](#) is set to a non-zero value during power-on, parameters are prevented from being modified by using the user password function. When you modify function parameters through serial communication, the user password protection function is also applicable and compliant with the same rule.

P00 group—Basic functions

Function code	Name	Description	Default	Modify
P00.00	Speed control mode	0: Sensorless vector control (SVC) mode 0 1: Sensorless vector control (SVC) mode 1 2: Space voltage vector control mode 3: Closed-loop vector control mode Note: Before using a vector control mode (0, 1, or 3), enable the VFD to perform motor parameter autotuning first.	2	☉
P00.01	Channel of running commands	0: Keypad 1: Terminal 2: Communication	0	○
P00.02	Communication mode of running commands	0: Modbus/Modbus TCP 1: PROFIBUS/CANopen/DeviceNet 2: Ethernet 3: EtherCAT/PROFINET/EtherNet IP 4: Programmable expansion card 5: Wireless communication card 6: 216 communication card 7: USB (Reserved) Note: The options 1, 2, 3, 4, 5, 6 and 7 are add-on functions and are available only when corresponding expansion cards are configured.	0	○
P00.03	Max. output frequency	Used to set the max. output frequency of the VFD. Pay attention to the function code because it is the foundation of the frequency setting and the speed of acceleration (ACC) and deceleration (DEC). Setting range: Max (P00.04 , 10.00)–150.00Hz	50.00Hz	☉
P00.04	Upper limit of running frequency	The upper limit of the running frequency is the upper limit of the output frequency of the VFD,	50.00Hz	☉

Function code	Name	Description	Default	Modify
		<p>which is lower than or equal to the max. output frequency.</p> <p>When the set frequency is higher than the upper limit of the running frequency, the upper limit of the running frequency is used for running.</p> <p>Setting range: P00.05–P00.03 (Max. output frequency)</p>		
P00.05	Lower limit of running frequency	<p>The lower limit of the running frequency is the lower limit of the output frequency of the VFD, When the set frequency is lower than the lower limit of the running frequency, the lower limit of the running frequency is used for running.</p> <p>Note: Max. output frequency ≥ Upper limit of frequency ≥ Lower limit of frequency</p> <p>Setting range: 0.00Hz–P00.04 (Upper limit of running frequency)</p>	0.00Hz	☉
P00.06	Setting channel of A frequency command	<p>0: Keypad</p> <p>1: AI1</p> <p>2: AI2</p>	0	○
P00.07	Setting channel of B frequency command	<p>3: AI3</p> <p>4: High-speed pulse HDIA</p> <p>5: Simple PLC program</p> <p>6: Multi-step speed running</p> <p>7: PID control</p> <p>8: Modbus/Modbus TCP communication</p> <p>9: PROFIBUS/CANopen/DeviceNet communication</p> <p>10: Ethernet communication</p> <p>11: High-speed pulse HDIB</p> <p>12: Pulse train AB</p> <p>13: EtherCAT/PROFINET/EtherNet IP communication</p> <p>14: Programmable expansion card</p> <p>15: Multi-step speed run</p> <p>16: 216 communication</p>	1	○
P00.08	Reference object of B frequency command	<p>0: Max. output frequency</p> <p>1: A frequency command</p>	0	○

Function code	Name	Description	Default	Modify										
P00.09	Combination mode of setting source	0: A 1: B 2: (A+B) 3: (A-B) 4: Max(A, B) 5: Min(A, B)	0	<input type="radio"/>										
P00.10	Frequency set through keypad	When A and B frequency commands select the keypad for setting, the value is the original setting one of the frequency data of VFD. Setting range: 0.00 Hz– P00.03 (Max. output frequency)	50.00Hz	<input type="radio"/>										
P00.11	ACC time 1	ACC time means the time needed if the VFD speeds up from 0Hz to the max. output frequency (P00.03). DEC time means the time needed if the VFD speeds down from the max. output frequency (P00.03) to 0Hz. The VFD has four groups of ACC/DEC time, which can be selected by P05. The factory default ACC/DEC time of the VFD is the first group. P00.11 and P00.12 setting range: 0.0–3600.0s	Model depended	<input type="radio"/>										
P00.12	DEC time 1		Model depended	<input type="radio"/>										
P00.13	Running direction	0: Run at the default direction. 1: Run at the opposite direction. 2: Disable reverse running Note: It can be modified only when P11.26 is 1 indicating special functions are enabled.	0	<input type="radio"/>										
P00.14	Carrier frequency	<table border="1"> <thead> <tr> <th>Carrier frequency</th> <th>Electro magnetic noise</th> <th>Noise and leakage current</th> <th>Cooling level</th> </tr> </thead> <tbody> <tr> <td>1kHz</td> <td rowspan="3">↑ High ↓ Low</td> <td rowspan="3">↑ Low ↓ High</td> <td rowspan="3">↑ Low ↓ High</td> </tr> <tr> <td>10kHz</td> </tr> <tr> <td>15kHz</td> </tr> </tbody> </table>	Carrier frequency	Electro magnetic noise	Noise and leakage current	Cooling level	1kHz	↑ High ↓ Low	↑ Low ↓ High	↑ Low ↓ High	10kHz	15kHz	Model depended	<input type="radio"/>
		Carrier frequency	Electro magnetic noise	Noise and leakage current	Cooling level									
		1kHz	↑ High ↓ Low	↑ Low ↓ High	↑ Low ↓ High									
		10kHz												
15kHz														
Mapping between models and carrier frequencies:														
Model	Default carrier frequency													
380V	0.4–11kW	4kHz												

Function code	Name	Description		Default	Modify	
			>15kW	1.5kHz		
		660V	22-55kW	4kHz		
			>75kW	2kHz		
		<p>Advantage of high carrier frequency: ideal current waveform, little current harmonic wave and motor noise.</p> <p>Disadvantage of high carrier frequency: increasing the switch loss, increasing VFD temperature and the impact to the output capacity. The VFD needs to derate on high carrier frequency. At the same time, the leakage and electrical magnetic interference will increase.</p> <p>On the contrary, an extremely-low a carrier frequency may cause unstable operation at low frequency, decrease the torque, or even lead to oscillation.</p> <p>The carrier frequency has been properly set in the factory before the VFD is delivered. In general, you do not need to modify it.</p> <p>When the frequency used exceeds the default carrier frequency, the VFD needs to derate by 10% for each increase of 1k carrier frequency.</p> <p>Setting range: 1.0-15.0kHz</p>				
P00.15	Motor parameter autotuning	<p>0: No operation</p> <p>1: Rotary autotuning.</p> <p>Comprehensive motor parameter autotuning. It is recommended to use rotating autotuning when high control accuracy is needed.</p> <p>2: Static autotuning 1 (comprehensive autotuning); static autotuning 1 is used in cases where the motor cannot be disconnected from load.</p> <p>3: Static autotuning 2 (partial autotuning); when the present motor is motor 1, only P02.06, P02.07, and P02.08 are autotuned; when the present motor is motor 2, only P12.06, P12.07, and P12.08 are autotuned.</p>		0	©	

Function code	Name	Description	Default	Modify
		4: Dynamic autotuning 2 (valid only for AMs) 5: Partial parameter static autotuning 2 (valid only for AMs)		
P00.16	AVR function selection	0: Disable 1: Valid during the whole procedure The auto-adjusting function of the VFD can eliminate the impact on the output voltage of the VFD because of the bus voltage fluctuation.	1	○
P00.18	Function parameter restore	Setting range of P00.18: 0–6 0: No operation 1: Restore default values (Excluding motor parameters) 2: Clear fault records 3: Lock keypad parameters 5: Restore default values (in factory test mode) 6: Restore default values (Including motor parameters) Note: After the selected operation is performed, the function code is automatically restored to 0. Restoring the default values may delete the user password. Exercise caution when using this function.	0	◎

P01 group—Start and stop control

Function code	Name	Description	Default	Modify
P01.00	Start mode	0: Direct start 1: Start after DC braking 2: Speed tracking restart 1 3: Speed tracking restart 2 Note: It can be modified only when P11.26 is 1 indicating special functions are enabled.	0	◎
P01.01	Starting frequency of direct start	The function code indicates the initial frequency during VFD start. See P01.02 (Starting frequency hold time) for detailed information. Setting range: 0.00–50.00Hz	0.50Hz	◎

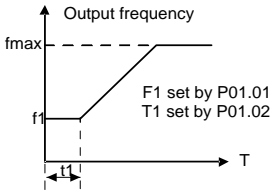
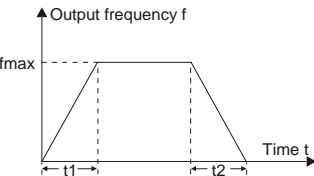
Function code	Name	Description	Default	Modify
P01.02	Starting frequency hold time	 <p>Setting a proper starting frequency can increase the torque during VFD start. During the hold time of the starting frequency, the output frequency of the VFD is the starting frequency. And then, the VFD runs from the starting frequency to the set frequency. If the set frequency is lower than the starting frequency, the VFD stops running and keeps in the standby state. The starting frequency is not limited in the lower limit frequency. Setting range: 0.0–50.0s</p>	0.0s	☉
P01.03	Braking current before start	<p>The VFD performs DC braking with the braking current before start and it speeds up after the DC braking time. If the set DC braking time is 0, DC braking is invalid.</p> <p>Stronger braking current indicates larger braking power. The DC braking current before start is a percentage of the VFD rated output current. P01.03 setting range: 0.0–100.0% P01.04 setting range: 0.00–50.00s</p>	0.0%	☉
P01.04	Braking time before start		0.00s	☉
P01.05	ACC/DEC mode	<p>Used to indicate the changing mode of the frequency during start and running.</p> <p>0: Linear type. The output frequency increases or decreases linearly.</p>  <p>1: S curve. The output frequency increases or decreases according to the S curve.</p>	0	☉

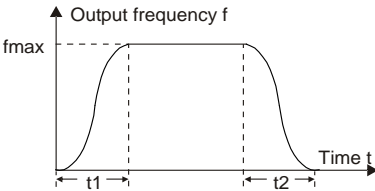
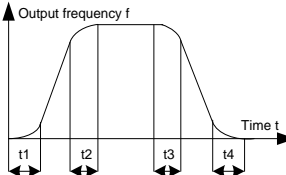
Function code	Name	Description	Default	Modify
		<p>The S curve is generally applied to elevators, conveyors, and other application scenarios where smoother start or stop is required.</p>  <p>2: Slewing application mode Note: When the function parameter is set to 1, you also need to set P01.06, P01.07, P01.27, and P01.28.</p>		
P01.06	Time of starting segment of ACC S curve	<p>The curvature of S curve is determined by the ACC range and ACC/DEC time.</p> 	0.1s	☉
P01.07	Time of ending segment of ACC S curve	<p>Setting range: 0.0–50.0s</p>	0.1s	☉
P01.08	Stop mode	<p>0: Decelerate to stop. After a stop command takes effect, the VFD lowers output frequency based on the DEC mode and the defined DEC time; after the frequency drops to the stop speed (P01.15), the VFD stops.</p> <p>1: Coast to stop. After a stop command takes effect, the VFD stops output immediately; and the load coasts to stop according to mechanical inertia.</p>	0	○
P01.09	Starting frequency of DC braking for stop	<p>Starting frequency of DC braking for stop: During the deceleration to stop, the VFD starts DC braking for stop when running frequency reaches the starting frequency determined by P01.09.</p>	0.00Hz	○
P01.10	Demagnetization time		0.00s	○
P01.11	DC braking	Wait time before DC braking: The VFD blocks	0.0%	○

Function code	Name	Description	Default	Modify
	current for stop	the output before starting DC braking. After this wait time, DC braking is started so as to prevent overcurrent caused by DC braking at high speed.		
P01.12	DC braking time for stop	<p>DC braking current for stop: It indicates the applied DC braking energy. Stronger current indicates greater DC braking effect.</p> <p>DC braking time for stop: It indicates the hold time of DC braking. If the time is 0, DC braking is invalid, and the VFD decelerates to stop within the specified time.</p> <p>P01.09 setting range: 0.00Hz–P00.03 (Max. output frequency) P01.10 setting range: 0.00–30.00s P01.11 setting range: 0.0–100.0% (of the rated VFD output current) P01.12 setting range: 0.0–50.0s</p>	0.00s	○
P01.13	FWD/REV running deadzone time	<p>This function code indicates the transition time specified in P01.14 during FWD/REV rotation switching. See the following figure:</p> <p>Setting range: 0.0–3600.0s</p>	0.0s	○
P01.14	FWD/REV running switching mode	<p>0: Switch at zero frequency 1: Switch at the starting frequency 2: Switch after the speed reaches the stop</p>	1	◎

Function code	Name	Description	Default	Modify
		speed with a delay		
P01.15	Stop speed	0.00–100.00Hz	0.50Hz	☉
P01.16	Stop speed detection mode	0: Detect by the set speed (unique in space voltage vector control mode) 1: Detect by the feedback speed	0	☉
P01.17	Stop speed detection time	0.00–100.00s	0.50s	☉
P01.18	Terminal-based running command protection at power-on	When the channel of running commands is terminal control, the system detects the state of the running terminal during power-on. 0: The terminal running command is invalid at power-on. Even the running command is considered as valid during power-on, the VFD does not run and it keeps the protection state until the running command is canceled and enabled again. 1: The terminal running command is valid at power-on. If the running command is considered as valid during power-on, the VFD is started automatically after the initialization. 2: The terminal running command is invalid at power-on, and a fault is reported. (Power-on terminal command exception POE). During power on, the VFD does not run but reports the fault, although the running command terminal is valid. The fault disappears only when the running command is canceled. Note: Exercise caution before using this function. Otherwise, serious result may follow.	0	○
P01.19	Action selected when running frequency less than frequency lower limit (valid when frequency lower limit greater than 0)	The function code determines the running state of the VFD when the set frequency is lower than the lower-limit one. 0: Run at the frequency lower limit 1: Stop 2: Sleep The VFD coasts to stop when the set frequency is lower than the lower-limit one. If the set	0	☉

Function code	Name	Description	Default	Modify
		frequency exceeds the lower limit one again and it lasts for the time set by P01.20 , the VFD resumes the running state automatically.		
P01.20	Wake-up-from-sleep delay	<p>Used to set the wake-up-from-sleep delay time. When the running frequency of the VFD is lower than the lower limit, the VFD becomes standby. When the set frequency exceeds the lower limit one again and it lasts for the time set by P01.20, the VFD runs automatically.</p> <p>Setting range: 0.0–3600.0s (Valid only when P01.19=2)</p>	0.0s	○
P01.21	Power-off restart selection	<p>Indicates whether the VFD automatically runs after re-power on. 0: Disable 1: Enable. If the restart condition is met, the VFD runs automatically with the wait time P01.22.</p>	0	○
P01.22	Wait time for restart after power-off	<p>Indicates the wait time before the automatic running of the VFD that is re-powered on.</p> <p>Setting range: 0.0–3600.0s (Valid only when P01.21=1)</p>	1.0s	○
P01.23	Start delay	After a VFD running command is given, the VFD	0.0s	○

Function code	Name	Description	Default	Modify
		is in standby state and restarts with the delay defined by P01.23 to implement brake release. Setting range: 0.0–600.0s		
P01.24	Stop speed delay	0.0–600.0s	0.0s	<input type="radio"/>
P01.25	Open-loop 0Hz output selection	0: Output without voltage 1: Output with voltage 2: Output with the DC braking current for stop	0	<input type="radio"/>
P01.26	DEC time for emergency stop	0.0–60.0s	2.0s	<input type="radio"/>
P01.27	Time of starting segment of DEC S curve	0.0–50.0s	0.1s	<input checked="" type="radio"/>
P01.28	Time of ending segment of DEC S curve	0.0–50.0s	0.1s	<input checked="" type="radio"/>
P01.29	Short-circuit braking current	When the VFD starts in direct start mode (P01.00 =0), set P01.30 to a non-zero value to	0.0%	<input type="radio"/>
P01.30	Hold time of short-circuit braking for start	enter short-circuit braking. During stop, if the running frequency of VFD is lower than the starting frequency of brake for stop (P01.09), set P01.31 to a non-zero value to	0.00s	<input type="radio"/>
P01.31	Hold time of short-circuit braking for stop	enter short-circuit braking for stop, and then carry out DC braking in the time set by P01.12 . (Refer to the descriptions for P01.09 – P01.12 .) P01.29 setting range: 0.0–150.0% (of the rated VFD output current) P01.30 setting range: 0.0–50.0s P01.31 setting range: 0.0–50.0s	0.00s	<input type="radio"/>
P01.32	Pre-exciting time for jogging	0–10.000s	0.000s	<input type="radio"/>
P01.33	Starting frequency of braking for stop in jogging	0–P00.03	0.00Hz	<input type="radio"/>
P01.34	Sleep delay	0–3600.0s	0.0s	<input type="radio"/>

P02 group—Parameters of motor 1

Function code	Name	Description	Default	Modify
P02.00	Type of motor 1	0: Asynchronous motor (AM) 1: Synchronous motor (SM)	0	☉
P02.01	Rated power of AM 1	0.1–3000.0kW	Model depended	☉
P02.02	Rated frequency of AM 1	0.01Hz– P00.03 (Max. output frequency)	50.00Hz	☉
P02.03	Rated speed of AM 1	1–36000rpm	Model depended	☉
P02.04	Rated voltage of AM 1	0–1200V	Model depended	☉
P02.05	Rated current of AM 1	0.8–6000.0A	Model depended	☉
P02.06	Stator resistance of AM 1	0.001–65.535Ω	Model depended	○
P02.07	Rotor resistance of AM 1	0.001–65.535Ω	Model depended	○
P02.08	Leakage inductance of AM 1	0.1–6553.5Mh	Model depended	○
P02.09	Mutual inductance of AM 1	0.1–6553.5Mh	Model depended	○
P02.10	No-load current of AM 1	0.1–6553.5A	Model depended	○
P02.11	Magnetic saturation coefficient 1 of iron core of AM 1	0.0–100.0%	80.0%	○
P02.12	Magnetic saturation coefficient 2 of iron core of AM 1	0.0–100.0%	68.0%	○
P02.13	Magnetic saturation coefficient 3 of iron core of AM 1	0.0–100.0%	57.0%	○
P02.14	Magnetic	0.0–100.0%	40.0%	○

Function code	Name	Description	Default	Modify
	saturation coefficient 4 of iron core of AM 1			
P02.15	Rated power of SM 1	0.1–3000.0kW	Model depended	☉
P02.16	Rated frequency of SM 1	0.01Hz– P00.03 (Max. output frequency)	50.00Hz	☉
P02.17	Number of pole pairs of SM 1	1–128	2	☉
P02.18	Rated voltage of SM 1	0–1200V	Model depended	☉
P02.19	Rated current of SM 1	0.8–6000.0A	Model depended	☉
P02.20	Stator resistance of SM 1	0.001–65.535Ω	Model depended	○
P02.21	Direct-axis inductance of SM 1	0.01–655.35Mh	Model depended	○
P02.22	Quadrature-axis inductance of SM 1	0.01–655.35Mh	Model depended	○
P02.23	Counter-emf of SM 1	0–10000	300	○
P02.24	Initial magnetic pole position of SM 1	0x0000–0xFFFF	0	●
P02.25	Identification current of SM 1	0%–50.0% (of the motor rated current)	10%	●
P02.26	Overload protection of motor 1	0: No protection 1: Common motor protection (with low-speed compensation). As the cooling effect of a common motor is degraded at low speed running, the corresponding electronic thermal protection value needs to be adjusted properly, the low compensation indicates lowering the overload protection threshold of the motor whose running frequency is lower than 30Hz.	2	☉

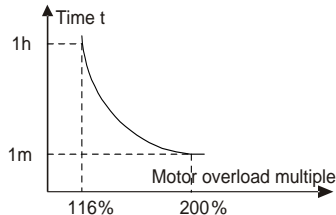
Function code	Name	Description	Default	Modify
		2: Variable-frequency motor protection (without low speed compensation). Because the heat dissipation function for a variable-frequency motor is not impacted by the rotation speed, it is not necessary to adjust the protection value at low speed running.		
P02.27	Overload protection coefficient of motor 1	<p>Motor overload multiples $M = I_{out} / (I_n * K)$</p> <p>I_n is rated motor current, I_{out} is VFD output current, K is motor overload protection coefficient.</p> <p>A smaller value of "K" indicates a bigger value of "M".</p> <p>When $M=116\%$, protection is performed after motor overload lasts for 1 hour; when $M=200\%$, protection is performed after motor overload lasts for 60 seconds; and when $M \geq 400\%$, protection is performed immediately.</p>  <p>Setting range: 20.0% –120.0%</p>	100.0%	<input type="radio"/>
P02.28	Power display calibration coefficient of motor 1	The function code can be used to adjust the power display value of motor 1. However, it does not affect the control performance of the VFD. Setting range: 0.00–3.00	1.00	<input type="radio"/>
P02.29	Parameter display of motor 1	0: Display by motor type. In this mode, only parameters related to the present motor type are displayed. 1: Display all. In this mode, all the motor parameters are displayed.	0	<input type="radio"/>
P02.30	System inertia of motor 1	0–30.000kgm ²	0	<input type="radio"/>
P02.31	Max. slip limit	When P02.31=0, the max. slip limit cannot be used.	0	<input checked="" type="radio"/>

Function code	Name	Description	Default	Modify
P02.32	Enabling flux-weakening two-zone control in closed-loop mode	0–1	0	☉

P03 group—Vector control of motor 1

Function code	Name	Description	Default	Modify
P03.00	Speed-loop proportional gain 1	<p>The parameters P03.00–P03.05 are applicable only to vector control mode. Below the switching frequency 1 (P03.02), the speed-loop PI parameters are: P03.00 and P03.01. Above the switching frequency 2 (P03.05), the speed-loop PI parameters are: P03.03 and P03.04. PI parameters are obtained according to the linear change of two groups of parameters. See the following figure:</p>	20.0	○
P03.01	Speed-loop integral time 1		0.200s	○
P03.02	Low-point frequency for switching		5.00Hz	○
P03.03	Speed-loop proportional gain 2		20.0	○
P03.04	Speed-loop integral time 2		0.200s	○
P03.05	High-point frequency for switching	<p>The speed loop dynamic response characteristics of vector control can be adjusted by setting the proportional coefficient and integral time of speed regulator. Increasing proportional gain or reducing integral time can accelerate dynamic response of speed loop; however, if the proportional gain is too large or integral time is too small, system oscillation and overshoot may occur; if proportional gain is too small, stable oscillation or speed offset may occur.</p> <p>PI parameters have a close relationship with the inertia of the system. Adjust PI parameters</p>	10.00Hz	○

Function code	Name	Description	Default	Modify
		depending on different loads to meet various demands. P03.00 setting range: 0.0–200.0 P03.01 setting range: 0.000–10.000s P03.02 setting range: 0.00Hz– P03.05 P03.03 setting range: 0.0–200.0 P03.04 setting range: 0.000–10.000s P03.05 setting range: P03.02 – P00.03 (Max. output frequency)		
P03.06	Speed-loop output filter	0–8 (corresponding to 0–2 ⁸ /10ms)	0	<input type="radio"/>
P03.07	Electromotive slip compensation coefficient of vector control	Slip compensation coefficient is used to adjust the slip frequency of the vector control and improve the speed control accuracy of the system. Adjusting the parameter properly can control the speed steady-state error. Setting range: 50–200%	100%	<input type="radio"/>
P03.08	Braking slip compensation coefficient of vector control		100%	<input type="radio"/>
P03.09	Current-loop proportional coefficient P	The two function codes impact the dynamic response speed and control accuracy of the system. Generally, you do not need to modify the two function codes.	1000	<input type="radio"/>
P03.10	Current-loop integral coefficient I	Applicable to SVC mode 0 (P00.00 =0), SVC mode 1 (P00.00 =1), and closed-loop vector control mode (P00.00 =3). Setting range: 0–65535	1000	<input type="radio"/>
P03.11	Torque setting method	0–1: Keypad (P03.12) 2: AI1 3: AI2 4: AI3 5: Pulse frequency HDIA 6: Multi-step torque 7: Modbus/Modbus TCP communication 8: PROFIBUS/CANopen/DeviceNet communication 9: Ethernet communication 10: Pulse frequency HDIB	0	<input type="radio"/>

Function code	Name	Description	Default	Modify
		11: EtherCAT/PROFINET/EtherNet IP communication 12: Programmable expansion card 13: 216 communication Note: For these settings, 100% corresponds to the motor rated current.		
P03.12	Torque set through keypad	-300.0%–300.0% (of the motor rated current)	20.0%	<input type="radio"/>
P03.13	Torque reference filter time	0.000–10.000s	0.010s	<input type="radio"/>
P03.14	Setting source of forward rotation upper-limit frequency in torque control	0: Keypad (P03.16) 1: AI1 2: AI2 3: AI3 4: Pulse frequency HDIA 5: Multi-step setting 6: Modbus/Modbus TCP communication 7: PROFIBUS/CANopen/DeviceNet communication 8: Ethernet communication 9: Pulse frequency HDIB 10: EtherCAT/PROFINET/EtherNet IP communication 11: Programmable expansion card 12: 216 communication Note: For these settings, 100% corresponds to the max. frequency.	0	<input type="radio"/>
P03.15	Setting source of reverse rotation upper-limit frequency in torque control	0: Keypad (P03.17) 1–12: Same as those for P03.14	0	<input type="radio"/>
P03.16	Forward rotation upper-limit frequency set through keypad in torque control	Used to set the frequency upper limits. 100% corresponds to the max. frequency. P03.16 sets the value when P03.14 =1; P03.17 sets the value when P03.15 =1. Setting range: 0.00Hz– P00.03 (Max. output	50.00Hz	<input type="radio"/>
P03.17	Reverse rotation	frequency)	50.00Hz	<input type="radio"/>

Function code	Name	Description	Default	Modify
	upper-limit frequency set through keypad in torque control			
P03.18	Setting source of electromotive torque upper limit	0: Keypad (P03.20) 1: AI1 2: AI2 3: AI3 4: Pulse frequency HDIA 5: Modbus/Modbus TCP communication 6: PROFIBUS/CANopen/DeviceNet communication 7: Ethernet communication 8: Pulse frequency HDIB 9: EtherCAT/PROFINET/EtherNet IP communication 10: Programmable expansion card 11: 216 communication Note: For these settings, 100% corresponds to the motor rated current.	0	<input type="radio"/>
P03.19	Setting source of braking torque upper limit	0: Keypad (P03.21) 1–11: Same as those for P03.18	0	<input type="radio"/>
P03.20	Electromotive torque upper limit set through keypad	0.0–300.0% (of the motor rated current) Note: It can be modified only when the ones place of P11.26 = 1 indicating special functions are enabled.	250.0%	<input type="radio"/>
P03.21	Braking torque upper limit set through keypad		250.0%	<input type="radio"/>
P03.22	Weakening coefficient in constant power zone	Used when the AM is in flux-weakening control.	0.3	<input type="radio"/>
P03.23	Lowest weakening point in constant power zone		20%	<input type="radio"/>

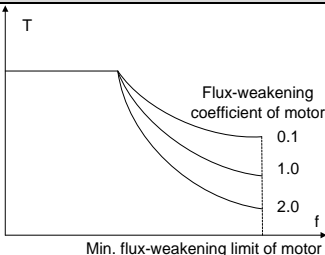
Function code	Name	Description	Default	Modify
		 <p>The function codes P03.22 and P03.23 are valid at constant power. The motor enters the flux-weakening state when the motor runs above the rated speed. Change the flux-weakening curvature by modifying the flux-weakening control coefficient. The larger the coefficient, the steeper the curve, the smaller the coefficient, the smoother the curve.</p> <p>P03.22 setting range: 0.1–2.0 P03.23 setting range: 10% –100.0%</p>		
P03.24	Max. voltage limit	P03.24 sets the max. output voltage of the VFD, which is the percentage of motor rated voltage. Set the value according to onsite conditions. Setting range: 0.0–120%	100.0%	<input type="radio"/>
P03.25	Pre-exciting time	Pre-exciting is performed for the motor when the VFD starts up. A magnetic field is built up inside the motor to improve the torque performance during the start process. Setting range: 0.000–10.000s	0.000s	<input type="radio"/>
P03.26	Flux-weakening proportional gain	0–8000	1000	<input type="radio"/>
P03.27	Speed display selection in vector control	0: Display the actual value 1: Display the set value	0	<input type="radio"/>
P03.28	Static friction compensation coefficient	0.0–100.0%	0.0%	<input type="radio"/>
P03.29	Corresponding frequency point of static friction	0.50– P03.31	1.00Hz	<input type="radio"/>

Function code	Name	Description	Default	Modify
P03.30	High speed friction compensation coefficient	0.0–100.0%	0.0%	<input type="radio"/>
P03.31	Corresponding frequency of high speed friction torque	P03.29 –400.00kHz	50.00Hz	<input type="radio"/>
P03.32	Enabling torque control	0: Disable 1: Enable	0	<input checked="" type="radio"/>
P03.33	Flux-weakening integral gain	0–8000	1200	<input type="radio"/>
P03.34	Flux-weakening control mode selection	0–0x112 Ones place: Control mode selection 0: Mode 0 1: Mode 1 2: Mode 2 Tens place: Compensation of inductance saturation coefficient 0: Yes 1: No Hundreds place: Whether to enable current loop feedforward compensation 0: Compensation 1: No compensation In mode 0, the weak magnetic current that is obtained from the weak magnetic curve is used to calculate the slip coefficient, while the number of filter times is fixed to 1. In mode 1, the actual weak magnetic current is used to calculate the slip coefficient, while the number of filter times is determined by the mutual inductance and rotor resistance. In mode 2, the actual weak magnetic current is used to calculate the slip coefficient, while the number of filter times is fixed to 1.	0x000	<input type="radio"/>
P03.35	Control optimization setting	0–0x1111 Ones place: Torque command selection 0: Torque giving	0x0000	<input type="radio"/>

Function code	Name	Description	Default	Modify
		1: Torque current reference Tens place: Reserved Hundreds place: indicates whether to enable speed-loop integral separation 0: Disable 1: Enable Thousands place: Reserved 0: Reserved 1: Reserved Range: 0x0000–0x1111		
P03.36	Speed-loop differential gain	0.00–10.00s	0.00s	<input type="radio"/>
P03.37	High-frequency current-loop proportional coefficient	In the closed-loop vector control mode (P00.00 =3), when the frequency is lower than the current-loop high-frequency switching threshold (P03.39), the current-loop PI parameters are P03.09 and P03.10 ; and when the frequency is higher than the current-loop high-frequency switching threshold, the current-loop PI parameters are P03.37 and P03.38 .	1000	<input type="radio"/>
P03.38	High-frequency current-loop integral coefficient	high-frequency switching threshold, the current-loop PI parameters are P03.37 and P03.38 .	1000	<input type="radio"/>
P03.39	Current-loop high-frequency switching threshold	P03.37 setting range: 0–65535 P03.38 setting range: 0–65535 P03.39 setting range: 0.0–100.0% (of the max. frequency)	100.0%	<input type="radio"/>
P03.40	Enabling inertia compensation	0: Disable 1: Enable	0	<input type="radio"/>
P03.41	Upper limit of inertia compensation torque	The max. inertia compensation torque is limited to prevent inertia compensation torque from being too large. Setting range: 0.0–150.0% (of the motor rated torque)	10.0%	<input type="radio"/>
P03.42	Inertia compensation filter times	Filter times of inertia compensation torque, used to smooth inertia compensation torque. Setting range: 0–10	7	<input type="radio"/>
P03.43	Inertia identification torque	Due to friction force, it is required to set certain identification torque for the inertia identification to be performed properly.	10.0%	<input type="radio"/>

Function code	Name	Description	Default	Modify
		0.0–100.0% (of the motor rated torque)		
P03.44	Enabling inertia identification	0: No operation 1: Enable	0	☉
P03.45	Current loop proportional coefficient after autotuning	0–65535	0	○
P03.46	Current integral proportional coefficient after autotuning	0–65535	0	○

P04 group—V/F control

Function code	Name	Description	Default	Modify
P04.00	V/F curve setting of motor 1	<p>This group of function code defines the V/F curve of motor 1 to meet the needs of different loads.</p> <p>0: Straight-line V/F curve, applicable to constant torque loads</p> <p>1: Multi-point V/F curve</p> <p>2: Torque-down V/F curve (power of 1.3)</p> <p>3: Torque-down V/F curve (power of 1.7)</p> <p>4: Torque-down V/F curve (power of 2.0)</p> <p>Curves 2 – 4 are applicable to the torque loads such as fans and water pumps. You can adjust according to the characteristics of the loads to achieve best performance.</p> <p>5: Customized V/F (V/F separation); in this mode, V can be separated from F and F can be adjusted through the frequency setting channel set by P00.06 or the voltage setting channel set by P04.27 to change the characteristics of the curve.</p> <p>Note: In the following figure, V_b is the motor rated voltage and f_b is the motor rated frequency.</p>	0	☉

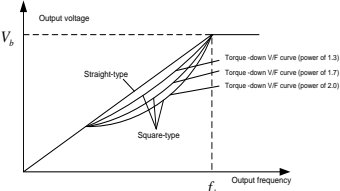
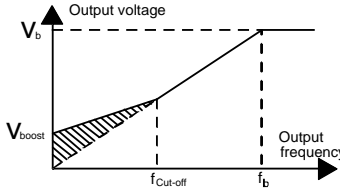
Function code	Name	Description	Default	Modify
				
P04.01	Torque boost of motor 1	<p>In order to compensate for low-frequency torque characteristics, you can make some boost compensation for the output voltage. P04.01 is relative to the max. output voltage V_b.</p>	0.0%	○
P04.02	Torque boost cut-off of motor 1	<p>P04.02 defines the percentage of cut-off frequency of manual torque boost to the rated motor frequency f_b. Torque boost can improve the low-frequency torque characteristics of V/F. You need to select torque boost based on the load. For example, larger load requires larger torque boost, however, if the torque boost is too large, the motor will run at over-excitation, which may cause increased output current and motor overheating, thus decreasing the efficiency. When torque boost is set to 0.0%, the VFD uses automatic torque boost.</p> <p>Torque boost cut-off threshold: Below this frequency threshold, torque boost is valid; exceeding this threshold will invalidate torque boost.</p>  <p>P04.01 setting range: 0.0%: Automatic; 0.1%–10.0% P04.02 setting range: 0.0% –50.0%</p>	20.0%	○
P04.03	V/F frequency point 1 of motor 1	<p>When P04.00=1 (multi-dot V/F curve), you can set the V/F curve through P04.03–P04.08.</p>	0.00Hz	○

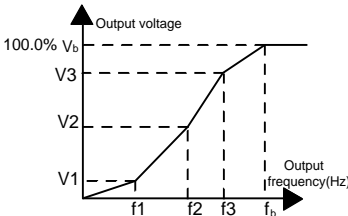
Function code	Name	Description	Default	Modify
P04.04	V/F voltage point 1 of motor 1	The V/F curve is generally set according to the load characteristics of the motor.	00.0%	<input type="radio"/>
P04.05	V/F frequency point 2 of motor 1	<p>Note: $V1 < V2 < V3$, $f1 < f2 < f3$. Too high voltage for low frequency will cause motor overheat or damage and cause VFD overcurrent stall or overcurrent protection.</p> 	0.00Hz	<input type="radio"/>
P04.06	V/F voltage point 2 of motor 1		0.0%	<input type="radio"/>
P04.07	V/F frequency point 3 of motor 1		0.00Hz	<input type="radio"/>
P04.08	V/F voltage point 3 of motor 1		<p>P04.03 setting range: 0.00Hz–P04.05</p> <p>P04.04 setting range: 0.0%–110.0% (of the rated voltage of motor 1)</p> <p>P04.05 setting range: P04.03–P04.07</p> <p>P04.06 setting range: 0.0%–110.0% (of the rated voltage of motor 1)</p> <p>P04.07 setting range: P04.05–P02.02 (Rated frequency of AM 1) or P04.05–P02.16 (Rated frequency of SM 1)</p> <p>P04.08 setting range: 0.0%–110.0% (of the rated voltage of motor 1)</p>	00.0%
P04.09	V/F slip compensation gain of motor 1	<p>Used to compensate for the motor rotating speed change caused by load change in the space voltage vector mode, and thus improve the rigidity of the mechanical characteristics of the motor. You need to calculate the rated slip frequency of the motor as follows:</p> $\Delta f = f_b - n * p / 60$ <p>Of which, f_b is the rated frequency of the motor, corresponding to function code P02.02. n is the rated rotating speed of the motor, corresponding to function code P02.03. p is the number of pole pairs of the motor. 100.0% corresponds to the rated slip frequency Δf of motor 1.</p>	0.0%	<input type="radio"/>

Function code	Name	Description	Default	Modify
		Setting range: 0.0–200.0%		
P04.10	Low-frequency oscillation control factor of motor 1	In space voltage vector control mode, the motor, especially the large-power motor, may experience current oscillation at certain frequencies, which may cause unstable motor running, or even VFD overcurrent. You can adjust the two function codes properly to eliminate such phenomenon. P04.10 setting range: 0–100 P04.11 setting range: 0–100 P04.12 setting range: 0.00Hz– P00.03 (Max. output frequency)	10	<input type="radio"/>
P04.11	High-frequency oscillation control factor of motor 1		10	<input type="radio"/>
P04.12	Oscillation control threshold of motor 1		30.00Hz	<input type="radio"/>
P04.13	V/F curve setting of motor 2	This group of function code defines the V/F curve of motor 2 to meet the needs of different loads. 0: Straight-line V/F curve 1: Multi-point V/F curve 2: Torque-down V/F curve (power of 1.3) 3: Torque-down V/F curve (power of 1.7) 4: Torque-down V/F curve (power of 2.0) 5: Customized V/F curve (V/F separation) Note: Refer to the description for P04.00 .	0	<input checked="" type="radio"/>
P04.14	Torque boost of motor 2	Note: Refer to the descriptions for P04.01 and P04.02 . P04.14 setting range: 0.0%: Automatic; 0.1%–10.0% P04.15 setting range: 0.0%–50.0% (of the rated frequency of motor 2)	0.0%	<input type="radio"/>
P04.15	Torque boost cut-off of motor 2		20.0%	<input type="radio"/>
P04.16	V/F frequency point 1 of motor 2	Note: Refer to the descriptions for P04.03 and P04.08 . P04.16 setting range: 0.00Hz– P04.18 P04.17 setting range: 0.0%–110.0% (of the rated voltage of motor 2) P04.18 setting range: P04.16 – P04.20 P04.19 setting range: 0.0%–110.0% (of the rated voltage of motor 2) P04.20 setting range: P04.18 – P12.02 (Rated	0.00Hz	<input type="radio"/>
P04.17	V/F voltage point 1 of motor 2		00.0%	<input type="radio"/>
P04.18	V/F frequency point 2 of motor 2		0.00Hz	<input type="radio"/>
P04.19	V/F voltage point 2 of motor 2		00.0%	<input type="radio"/>
P04.20	V/F frequency		0.00Hz	<input type="radio"/>

Function code	Name	Description	Default	Modify
P04.21	point 3 of motor 2	frequency of AM 2) or P04.18 – P12.16 (Rated frequency of SM 2) P04.21 setting range: 0.0%–110.0% (of the rated voltage of motor 2)	00.0%	<input type="radio"/>
	V/F voltage point 3 of motor 2			
P04.22	V/F slip compensation gain of motor 2	Used to compensate for the motor rotating speed change caused by load change in the space voltage vector mode, and thus improve the rigidity of the mechanical characteristics of the motor. You need to calculate the rated slip frequency of the motor as follows: $\Delta f = f_b - n * p / 60$ Of which, f_b is the rated frequency of the motor 2, corresponding to function code P12.02 . n is the rated rotating speed of the motor 2, corresponding to function code P12.03 . p is the number of pole pairs of the motor. 100.0% corresponds to the rated slip frequency Δf of motor 2. Setting range: 0.0–200.0%	0.0%	<input type="radio"/>
P04.23	Low-frequency oscillation control factor of motor 2	In space voltage vector control mode, the motor, especially the large-power motor, may experience current oscillation at certain frequencies, which may cause unstable motor running, or even VFD overcurrent. You can adjust the two function codes properly to eliminate such phenomenon. P04.23 setting range: 0–100 P04.24 setting range: 0–100 P04.25 setting range: 0.00Hz– P00.03 (Max. output frequency)	10	<input type="radio"/>
P04.24	High-frequency oscillation control factor of motor 2		10	<input type="radio"/>
P04.25	Oscillation control threshold of motor 2		30.00Hz	<input type="radio"/>
P04.26	Energy-saving run	0: Disable 1: Automatic energy-saving run In light-load state, the motor can adjust the output voltage automatically to achieve energy saving.	0	<input checked="" type="radio"/>
P04.27	Voltage setting channel	0: Keypad (The output voltage is determined by P04.28 .) 1: AI1	0	<input type="radio"/>

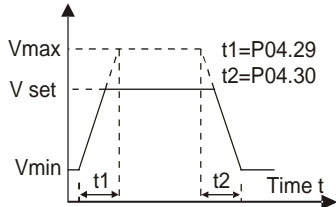
Function code	Name	Description	Default	Modify
		2: AI2 3: AI3 4: HDIA 5: Multi-step speed running (The setting is determined by group P10.) 6: PID 7: Modbus/Modbus TCP communication 8: PROFIBUS/CANopen/DeviceNet communication 9: Ethernet communication 10: HDIB 11: EtherCAT/PROFINET/EtherNet IP communication 12: Programmable expansion card 13: 216 communication		
P04.28	Voltage set through keypad	The function code is the voltage digital setting when "keypad" is selected as the voltage setting channel. Setting range: 0.0%–100.0%	100.0%	○
P04.29	Voltage increase time	Voltage increase time means the time needed for the VFD to accelerate from min. output voltage to the max. output frequency. Voltage decrease time means the time needed for the VFD to decelerate from the max. output frequency to min. output voltage. Setting range: 0.0–3600.0s	5.0s	○
P04.30	Voltage decrease time		5.0s	○
P04.31	Max. output voltage	The function codes are used to set the upper and lower limits of output voltage.	100.0%	◎
P04.32	Output min. voltage	 <p> P04.31 setting range: P04.32 –100.0% (of the motor rated voltage) P04.32 setting range: 0.00Hz–P04.31 </p>	0.0%	◎

Function code	Name	Description	Default	Modify
P04.33	Weakening coefficient in constant power zone	1.00–1.30	1.00	<input type="radio"/>
P04.34	Pull-in current 1 in SM V/F control	When the SM VF control mode is enabled, the function code is used to set the reactive current of the motor when the output frequency is lower than the frequency specified by P04.36 . Setting range: -100.0%–+100.0% (of the motor rated current)	20.0%	<input type="radio"/>
P04.35	Pull-in current 2 in SM V/F control	When the SM VF control mode is enabled, the function code is used to set the reactive current of the motor when the output frequency is lower than the frequency specified by P04.36 . Setting range: -100.0%–+100.0% (of the motor rated current)	10.0%	<input type="radio"/>
P04.36	Frequency threshold for pull-in current switching in SM V/F control	When the SM VF control mode is enabled, the function code is used to set the frequency threshold for the switching between pull-in current 1 and pull-in current 2. Setting range: 0.0–200.0% (of the motor rated frequency)	20.0%	<input type="radio"/>
P04.37	Reactive current closed-loop proportional coefficient in SM V/F control	When the SM VF control mode is enabled, the function code is used to set the proportional coefficient of reactive current closed-loop control. Setting range: 0–3000	50	<input type="radio"/>
P04.38	Reactive current closed-loop integral time in SM V/F control	When the SM VF control mode is enabled, the function code is used to set the integral coefficient of reactive current closed-loop control. Setting range: 0–3000	30	<input type="radio"/>
P04.39	Reactive current closed-loop output limit in SM VF control	When the SM VF control mode is enabled, the function code is used to set the output limit of the reactive current closed-loop control. A greater value indicates a higher reactive closed-loop compensation voltage and higher output power of the motor. In general, you do	8000	<input type="radio"/>

Function code	Name	Description	Default	Modify
		not need to modify the function code. Setting range: 0–16000		
P04.40	Enabling I/F mode for AM 1	0: Disable 1: Enable Note: The I/F mode is not applicable to conical motors.	0	☉
P04.41	Forward current setting in I/F mode for AM 1	When I/F control is adopted for AM 1, this parameter is used to set the output current. The value is a percentage in relative to the rated current of the motor. Setting range: 0.0–200.0%	120.0%	○
P04.42	Proportional coefficient in I/F mode for AM 1	When I/F control is adopted for AM 1, this parameter is used to set the proportional coefficient of the output current in closed-loop control. Setting range: 0–5000	350	○
P04.43	Integral coefficient in I/F mode for AM 1	When I/F control is adopted for AM 1, this parameter is used to set the integral coefficient of the output current in closed-loop control. Setting range: 0–5000	150	○
P04.44	Starting frequency for switching off I/F mode for AM 1	When I/F control is adopted for AM 1, this parameter is used to set the starting frequency for switching off the output current closed-loop control. When the output frequency is lower than the value of this parameter, the current closed-loop control in the I/F control mode is enabled; and when the output frequency is higher than P04.50, the current closed-loop control in the I/F control mode is disabled.	10.00Hz	○

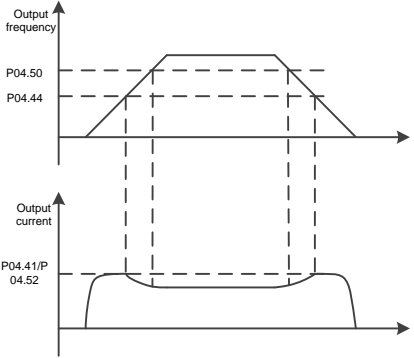
Function code	Name	Description	Default	Modify
		 <p>Setting range: 0.00–20.00 Hz</p>		
P04.45	Enabling I/F mode for AM 2	0: Disable 1: Enable Note: The I/F mode is not applicable to conical motors.	0	☉
P04.46	Forward current setting in I/F mode for AM 2	When I/F control is adopted for AM 2, this parameter is used to set the output current. The value is a percentage in relative to the rated current of the motor. Setting range: 0.0–200.0%	120.0%	○
P04.47	Proportional coefficient in I/F mode for AM 2	When I/F control is adopted for AM 2, the function code is used to set the proportional coefficient of output current in closed-loop control. Setting range: 0–5000	350	○
P04.48	Integral coefficient in I/F mode for AM 2	When I/F control is adopted for AM 2, the function code is used to set the integral coefficient of output current in closed-loop control. Setting range: 0–5000	150	○
P04.49	Starting frequency for switching off I/F mode for AM 2	When I/F control is adopted for AM 2, this parameter is used to set the starting frequency for switching off the output current closed-loop control. When the output frequency is lower than the value of this parameter, the current closed-loop control in the I/F control mode is	10.00Hz	○

Function code	Name	Description	Default	Modify
		enabled; and when the output frequency is higher than P04.51, the current closed-loop control in the I/F control mode is disabled. Setting range: 0.00–20.00 Hz		
P04.50	End frequency for switching off I/F mode for motor 1	P04.44–P00.03	25.00Hz	○
P04.51	End frequency for switching off I/F mode for motor 2	P04.49–P00.03	25.00Hz	○
P04.52	Reverse current setting in I/F mode for AM 1	0.0–200.0%	120.0%	○
P04.53	Reverse current setting in I/F mode for AM 2	0.0–200.0%	120.0%	○

P05 group—Input terminals

Function code	Name	Description	Default	Modify
P05.00	HDI input type	0x00–0x11 Ones place: HDIA input type 0: HDIA is high-speed pulse input 1: HDIA is digital input Tens place: HDIB input type 0: HDIB is high-speed pulse input 1: HDIB is digital input	0x00	◎
P05.01	Function of S1	0: No function	1	◎
P05.02	Function of S2	1: Run forward	2	◎
P05.03	Function of S3	2: Run reversely	7	◎
P05.04	Function of S4	3: Three-wire running control	0	◎
P05.05	Function of HDIA	4: Jog forward	0	◎
P05.06	Function of HDIB	5: Jog reversely	0	◎
P05.07	Reserved	6: Coast to stop 7: Reset faults 8: Pause running 9: External fault input 10: Increase frequency setting (UP)	0	◎

Function code	Name	Description	Default	Modify
		11: Decrease frequency setting (DOWN) 12: Clear the frequency increase/decrease setting 13: Switch between A setting and B setting 14: Switch between combination setting and A setting 15: Switch between combination setting and B setting 16: Multi-step speed terminal 1 17: Multi-step speed terminal 2 18: Multi-step speed terminal 3 19: Multi-step speed terminal 4 20: Pause multi-step speed running 21: ACC/DEC time selection 1 22: ACC/DEC time selection 2 23: Simple PLC stop reset 24: Pause simple PLC 25: Pause PID control 26: Pause wobbling frequency 27: Reset wobbling frequency 28: Counter reset 29: Switch between speed control and torque control 30: Disable ACC/DEC 31: Trigger the counter 32: Reserved 33: Clear the frequency increase/decrease setting temporarily 34: DC braking 35: Switch from motor 1 to motor 2 36: Switch the running command channel to keypad 37: Switch the running command channel to terminal 38: Switch the running command channel to communication 39: Pre-exciting command 40: Clear electricity consumption		

Function code	Name	Description	Default	Modify
		41: Keep electricity consumption 42: Switch the setting source of braking torque upper limit to keypad 43: Position reference point input (only valid for S2, S3 and S4) 44: Disable spindle orientation 45: Spindle zeroing / Local positioning zeroing 46: Spindle zeroing position selection 1 47: Spindle zeroing position selection 2 48: Spindle scale division selection 1 49: Spindle scale division selection 2 50: Spindle scale division selection 3 51: Terminal for switching between position control and speed control 52: Disable pulse input 53: Clear position deviation 54: Switch position proportional gains 55: Enable cyclic digital positioning 56: Emergency stop 57: Motor overtemperature fault input 58: Enable rigid tapping 59: Switch to V/F control 60: Switch to FVC control 61: Switch PID polarities 62: Switch to SVC1 control (open-loop vector control 1) 63: Enable servo 64: Limit of forward run (upward) 65: Limit of reverse run (downward) 66: Clear encoder counting 67: Increase pulses 68: Enable pulse superposition 69: Decrease pulses 70: Electronic gear selection 71: Switch to the master 72: Switch to the slave 73: Enable the VFD 74: Contactor feedback signal		

Function code	Name	Description	Default	Modify
		75: Brake feedback signal 76: Operating lever zero-point position 77: Graded reference terminal 1 78: Graded reference terminal 2 79: Graded reference terminal 3 80: Graded reference terminal 4 81: Graded reference terminal 5 82: Upward DEC limit position 83: Downward DEC limit position 84: Light load speed boost signal 85: Brake detection 86: PTC overtemperature valid signal (supporting only S8 of EC-IO502-00) 87: Reset the position synchronization pulse counting 88: Switch from motor 1 to motor 3 89: Anti-snap protection input 90: Enable anti-sway 91: Switch from master/slave mode to a non master/slave mode 92: Enable sway reducing 93: Braking by foot brakes		
P05.08	Input terminal polarity	Used to set the polarity of input terminals. When a bit is 0, the input terminal is positive; when a bit is 1, the input terminal is negative. 0x000–0x3F Corresponding to HDIB, HDIA, S4, S3, S2, and S1 in sequence	0x000	○
P05.09	Digital input filter time	The function code is used to set the filter time for S1–S4, HDIA, and HDIB. In strong interference cases, increase the value to avoid maloperation. 0.000–1.000s	0.010s	○
P05.10	Virtual terminal setting	0x000–0x3F (0: Disable. 1: Enable) BIT0: S1 virtual terminal BIT1: S2 virtual terminal BIT2: S3 virtual terminal BIT3: S4 virtual terminal BIT4: HDIA virtual terminal	0x00	◎

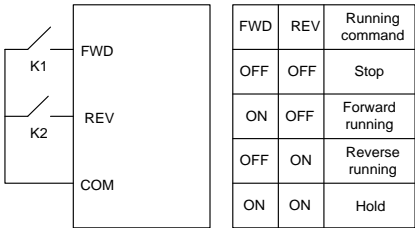
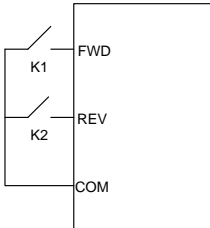
Function code	Name	Description	Default	Modify																														
		BIT5: HDIB virtual terminal																																
P05.11	Terminal control mode	<p>Used to set the mode of terminal control.</p> <p>0: Two-wire control 1, the enabling consistent with the direction. This mode is widely used. The defined FWD/REV terminal command determines the motor rotation direction.</p>  <table border="1" data-bbox="613 416 792 639"> <thead> <tr> <th>FWD</th> <th>REV</th> <th>Running command</th> </tr> </thead> <tbody> <tr> <td>OFF</td> <td>OFF</td> <td>Stop</td> </tr> <tr> <td>ON</td> <td>OFF</td> <td>Forward running</td> </tr> <tr> <td>OFF</td> <td>ON</td> <td>Reverse running</td> </tr> <tr> <td>ON</td> <td>ON</td> <td>Hold</td> </tr> </tbody> </table> <p>1: Two-wire control 2, the enabling separated from the direction. In this mode, FWD is the enabling terminal. The direction depends on the defined REV state.</p>  <table border="1" data-bbox="613 772 796 1000"> <thead> <tr> <th>FWD</th> <th>REV</th> <th>Running command</th> </tr> </thead> <tbody> <tr> <td>OFF</td> <td>OFF</td> <td>Stop</td> </tr> <tr> <td>ON</td> <td>OFF</td> <td>Forward running</td> </tr> <tr> <td>OFF</td> <td>ON</td> <td>Stop</td> </tr> <tr> <td>ON</td> <td>ON</td> <td>Reverse running</td> </tr> </tbody> </table> <p>2: Three-wire control 1. This mode defines Sin as the enabling terminal, and the running command is generated by FWD, while the direction is controlled by REV. During running, the Sin terminal needs to be closed, and terminal FWD generates a rising edge signal, then the VFD starts to run in the direction set by the state of terminal REV; the VFD needs to be stopped by disconnecting terminal Sin.</p>	FWD	REV	Running command	OFF	OFF	Stop	ON	OFF	Forward running	OFF	ON	Reverse running	ON	ON	Hold	FWD	REV	Running command	OFF	OFF	Stop	ON	OFF	Forward running	OFF	ON	Stop	ON	ON	Reverse running	0	©
FWD	REV	Running command																																
OFF	OFF	Stop																																
ON	OFF	Forward running																																
OFF	ON	Reverse running																																
ON	ON	Hold																																
FWD	REV	Running command																																
OFF	OFF	Stop																																
ON	OFF	Forward running																																
OFF	ON	Stop																																
ON	ON	Reverse running																																

Function code	Name	Description	Default	Modify																						
		<div data-bbox="384 220 586 424" data-label="Diagram"> </div> <p data-bbox="384 437 739 491">The direction control is as follows during running:</p> <table border="1" data-bbox="387 494 804 778"> <thead> <tr> <th>Sin</th> <th>REV</th> <th>Previous direction</th> <th>Present direction</th> </tr> </thead> <tbody> <tr> <td rowspan="2">ON</td> <td rowspan="2">OFF→ON</td> <td>FWD run</td> <td>REV run</td> </tr> <tr> <td>REV run</td> <td>FWD run</td> </tr> <tr> <td rowspan="2">ON</td> <td rowspan="2">ON→OFF</td> <td>REV run</td> <td>FWD run</td> </tr> <tr> <td>FWD run</td> <td>REV run</td> </tr> <tr> <td>ON→OFF</td> <td>ON</td> <td colspan="2" rowspan="2">Decelerate to stop</td> </tr> <tr> <td>OFF</td> <td>OFF</td> </tr> </tbody> </table> <p data-bbox="384 788 804 842">Sin: Three-wire control; FWD: Forward running; REV: Reverse running</p> <p data-bbox="384 852 804 1129">3: Three-wire control 2. This mode defines Sin as the enabling terminal, and the running command is generated by FWD or REV, but the direction is controlled by both FWD and REV. During running, the Sin terminal needs to be closed, and terminal FWD or REV generates a rising edge signal to control the running and direction of the VFD; the VFD needs to be stopped by disconnecting terminal Sin.</p> <div data-bbox="384 1139 631 1385" data-label="Diagram"> </div>	Sin	REV	Previous direction	Present direction	ON	OFF→ON	FWD run	REV run	REV run	FWD run	ON	ON→OFF	REV run	FWD run	FWD run	REV run	ON→OFF	ON	Decelerate to stop		OFF	OFF		
Sin	REV	Previous direction	Present direction																							
ON	OFF→ON	FWD run	REV run																							
		REV run	FWD run																							
ON	ON→OFF	REV run	FWD run																							
		FWD run	REV run																							
ON→OFF	ON	Decelerate to stop																								
OFF	OFF																									

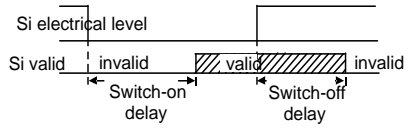
Function code	Name	Description	Default	Modify																					
		<table border="1"> <thead> <tr> <th>Sin</th> <th>FWD</th> <th>REV</th> <th>Running direction</th> </tr> </thead> <tbody> <tr> <td rowspan="2">ON</td> <td>OFF→ON</td> <td>ON</td> <td>FWD run</td> </tr> <tr> <td></td> <td>OFF</td> <td>FWD run</td> </tr> <tr> <td rowspan="2">ON</td> <td>ON</td> <td rowspan="2">OFF→ON</td> <td>REV run</td> </tr> <tr> <td>OFF</td> <td>REV run</td> </tr> <tr> <td>ON→OFF</td> <td></td> <td></td> <td>DEC to stop</td> </tr> </tbody> </table> <p>Sin: Three-wire control; FWD: Forward running; REV: Reverse running</p> <p>Note: For two-wire controlled running mode, when the FWD/REV terminal is valid, if the VFD stops due to a stop command given by another source, the VFD does not run again after the stop command disappears even if the control terminal FWD/REV is still valid. To make the VFD run, you need to trigger FWD/REV again, for example, PLC single-cycle stop, fixed-length stop, and valid STOP/RST stop during terminal control. (See P07.04.)</p>	Sin	FWD	REV	Running direction	ON	OFF→ON	ON	FWD run		OFF	FWD run	ON	ON	OFF→ON	REV run	OFF	REV run	ON→OFF			DEC to stop		
Sin	FWD	REV	Running direction																						
ON	OFF→ON	ON	FWD run																						
		OFF	FWD run																						
ON	ON	OFF→ON	REV run																						
	OFF		REV run																						
ON→OFF			DEC to stop																						
P05.12	S1 switch-on delay	<p>Used to specify the delay time corresponding to the electrical level changes when the programmable input terminals switch on or switch off.</p>  <p>Setting range: 0.000–50.000s</p> <p>Note: After a virtual terminal is enabled, the state of the terminal can be changed only in communication mode. The communication address is 0x200A.</p>	0.000s	○																					
P05.13	S1 switch-off delay		0.000s	○																					
P05.14	S2 switch-on delay		0.000s	○																					
P05.15	S2 switch-off delay		0.000s	○																					
P05.16	S3 switch-on delay		0.000s	○																					
P05.17	S3 switch-off delay		0.000s	○																					
P05.18	S4 switch-on delay		0.000s	○																					
P05.19	S4 switch-off		0.000s	○																					

Function code	Name	Description	Default	Modify
	delay			
P05.20	HDIA switch-on delay		0.000s	<input type="radio"/>
P05.21	HDIA switch-off delay		0.000s	<input type="radio"/>
P05.22	HDIB switch-on delay		0.000s	<input type="radio"/>
P05.23	HDIB switch-off delay		0.000s	<input type="radio"/>
P05.24	AI1 lower limit	Used to define the relationship between the analog input voltage and its corresponding setting. When the analog input voltage exceeds the range from the upper limit to the lower limit, the upper limit or lower limit is used.	0.00V	<input type="radio"/>
P05.25	Corresponding setting of AI1 lower limit		0.0%	<input type="radio"/>
P05.26	AI1 upper limit		10.00V	<input type="radio"/>
P05.27	Corresponding setting of AI1 upper limit	When the analog input is current input, 0mA–20mA current corresponds to 0V–10V voltage. In different applications, 100.0% of the analog setting corresponds to different nominal values. See the descriptions of each application section for details.	100.0%	<input type="radio"/>
P05.28	AI1 input filter time		0.030s	<input type="radio"/>
P05.29	AI2 lower limit		-10.00V	<input type="radio"/>
P05.30	Corresponding setting of AI2 lower limit	The following figure illustrates the cases of several settings:	-100.0%	<input type="radio"/>
P05.31	AI2 middle value 1		0.00V	<input type="radio"/>
P05.32	Corresponding setting of AI2 middle value 1		0.0%	<input type="radio"/>
P05.33	AI2 middle value 2		0.00V	<input type="radio"/>
P05.34	Corresponding setting of AI2 middle value 2		0.0%	<input type="radio"/>
P05.35	AI2 upper limit	Input filter time: to adjust the sensitivity of analog input. Increasing the value properly can enhance analog input anti-interference but may reduce the sensitivity of analog input.	10.00V	<input type="radio"/>
P05.36	Corresponding setting of AI2 upper limit	Note: AI1 supports the 0–10V/0–20mA input.	100.0%	<input type="radio"/>
P05.37	AI2 input filter time	When AI1 selects the 0–20mA input, the corresponding voltage of 20mA is 10V. AI2	0.030s	<input type="radio"/>

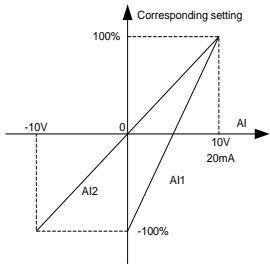

Function code	Name	Description	Default	Modify
		supports the -10~+10V input. P05.24 setting range: 0.00V~ P05.26 P05.25 setting range: -300.0% ~-300.0% P05.26 setting range: P05.24 ~10.00V P05.27 setting range: -300.0% ~-300.0% P05.28 setting range: 0.000s~10.000s P05.29 setting range: -10.00V~ P05.31 P05.30 setting range: -300.0% ~-300.0% P05.31 setting range: P05.29 ~ P05.33 P05.32 setting range: -300.0% ~-300.0% P05.33 setting range: P05.31 ~ P05.35 P05.34 setting range: -300.0% ~-300.0% P05.35 setting range: P05.33 ~10.00V P05.36 setting range: -300.0% ~-300.0% Setting range of P05.37 : 0.000s~10.000s		
P05.38	HDIA high-speed pulse input function selection	0: Input set through frequency 1: Reserved 2: Input set through encoder, used together with HDIB	0	☉
P05.39	HDIA lower limit frequency	0.000 kHz~ P05.41	0.000 kHz	○
P05.40	Corresponding setting of HDIA lower limit frequency	-300.0%~300.0%	0.0%	○
P05.41	HDIA upper limit frequency	P05.39 ~50.000kHz	50.000 kHz	○
P05.42	Corresponding setting of HDIA upper limit frequency	-300.0%~300.0%	100.0%	○
P05.43	HDIA frequency input filter time	0.000s~10.000s	0.030s	○
P05.44	HDIB high-speed pulse input function selection	0: Input set through frequency 1: Reserved 2: Input set through encoder, used with HDIA	0	☉
P05.45	HDIB lower limit	0.000 kHz – P05.47	0.000	○

Function code	Name	Description	Default	Modify
	frequency		kHz	
P05.46	Corresponding setting of HDIB lower limit frequency	-300.0%~300.0%	0.0%	<input type="radio"/>
P05.47	HDIB upper limit frequency	P05.45 ~50.000kHz	50.000 kHz	<input type="radio"/>
P05.48	Corresponding setting of HDIB upper limit frequency	-300.0%~300.0%	100.0%	<input type="radio"/>
P05.49	HDIB frequency input filter time	0.000s~10.000s	0.030s	<input type="radio"/>
P05.50	AI1 input signal type	0: Voltage 1: Current Note: You can set the AI1 input signal type through the corresponding function code.	0	<input checked="" type="radio"/>

P06 group—Output terminals

Function code	Name	Description	Default	Modify
P06.00	HDO output type	0: Open collector high-speed pulse output. The max. frequency of pulse is 50.00kHz. For details about the related functions, see P06.27~P06.31 . 1: Open collector output. For details about the related functions, see P06.02 .	0	<input checked="" type="radio"/>
P06.01	Y1 output	0: Disable	0	<input type="radio"/>
P06.02	HDO output	1: Running	0	<input type="radio"/>
P06.03	RO1 output	2: Running forward	1	<input type="radio"/>
P06.04	RO2 output	3: Running reversely 4: Jogging 5: VFD in fault 6: Frequency level detection FDT1 7: Frequency level detection FDT2 8: Frequency reached 9: Running in zero speed 10: Upper limit frequency reached 11: Lower limit frequency reached	5	<input type="radio"/>

Function code	Name	Description	Default	Modify
		12: Ready for running 13: Pre-exciting 14: Overload pre-alarm 15: Underload pre-alarm 16: Simple PLC stage completed 17: Simple PLC cycle completed 18: Set counting value reached 19: Designated counting value reached 20: External fault is valid 21: Reserved 22: Running time reached 23: Modbus/Modbus TCP communication virtual terminal output 24: PROFIBUS/CANopen/DeviceNet communication virtual terminal output 25: Ethernet communication virtual terminal output 26: DC bus voltage established 27: Z pulse output 28: Superposing pulses 29: STO action 30: Positioning completed 31: Spindle zeroing completed 32: Spindle scale division completed 33: In speed limit 34: EtherCAT/PROFINET/EtherNet IP communication virtual terminal output 35: Reserved 36: Speed/position control switchover completed 37: Any frequency reached 38: Non STO fault 39–40: Reserved 41: C_Y1 from PLC (Set P27.00 to 1.) 42: C_Y2 from PLC (Set P27.00 to 1.) 43: C_HDO from PLC (Set P27.00 to 1.) 44: C_RO1 from PLC (Set P27.00 to 1.) 45: C_RO2 from PLC (Set P27.00 to 1.) 46: C_RO3 from PLC (Set P27.00 to 1.)		

Function code	Name	Description	Default	Modify								
		47: C_RO4 from PLC (Set P27.00 to 1.) 48: Contactor output 50: Brake output 50: Ready to release the brake 51: Ready to close the brake 52: The upward limit position is reached. 53: The downward limit position is reached. 54: Low voltage protection 55: Overload protection 56: Brake detection reminding 57: Brake failure alarm 58: Input phase loss alarm 59: Loose rope status (FWD loose rope protection, REV loose rope alarm or fault) 60: In motor 1 state 61: In motor 2 state 62: In motor 3 state 63: PT100 temperature alarm 64: PT1000 temperature alarm 65: Boosting the speed with light load 66: Frequency decrease with voltage 67: Weighing alarm 68: AI detected temperature alarm 69: 216 communication virtual terminal output 70: In stopped state or running at zero speed										
P06.05	Output terminal polarity selection	Used to set the polarity of output terminals. When a bit is 0, the input terminal is positive; when a bit is 1, the input terminal is negative. <table border="1" style="margin-left: 20px;"> <tr> <td style="border: 1px solid black;">BIT3</td> <td style="border: 1px solid black;">BIT2</td> <td style="border: 1px solid black;">BIT1</td> <td style="border: 1px solid black;">BIT0</td> </tr> <tr> <td style="border: 1px solid black;">RO2</td> <td style="border: 1px solid black;">RO1</td> <td style="border: 1px solid black;">HDO</td> <td style="border: 1px solid black;">Y1</td> </tr> </table> Setting range: 0x0 -0xF	BIT3	BIT2	BIT1	BIT0	RO2	RO1	HDO	Y1	00	○
BIT3	BIT2	BIT1	BIT0									
RO2	RO1	HDO	Y1									
P06.06	Y1 switch-on delay	Used to specify the delay time corresponding to the electrical level changes when the programmable output terminals switch on or switch off.	0.000s	○								
P06.07	Y1 switch-off delay		0.000s	○								
P06.08	HDO switch-on delay		0.000s	○								

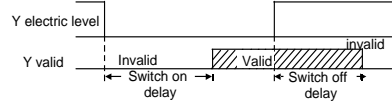
Function code	Name	Description	Default	Modify
P06.09	HDO switch-off delay	 <p>Setting range: 0.000–50.000s Note: P06.08 and P06.09 are valid only when P06.00=1.</p>	0.000s	<input type="radio"/>
P06.10	RO1 switch-on delay		0.000s	<input type="radio"/>
P06.11	RO1 switch-off delay		0.000s	<input type="radio"/>
P06.12	RO2 switch-on delay		0.000s	<input type="radio"/>
P06.13	RO2 switch-off delay		0.000s	<input type="radio"/>
P06.14	AO1 output		0: Running frequency (0–Max. output frequency)	0
P06.16	HDO high-speed pulse output	1: Set frequency (0–Max. output frequency) 2: Ramp reference frequency (0–Max. output frequency) 3: Rotational speed (0–Speed corresponding to max. output frequency) 4: Output (0–Twice the inverter unit rated current) 5: Output current (0–Twice the motor rated current) 6: Output (0–1.5 times the inverter unit rated voltage) 7: Output power (0–Twice the motor rated power) 8: Set torque (0–Twice the motor rated torque) 9: Output torque (Absolute value 0–±Twice the motor rated torque) 10: AI1 input (0–10V/0–20mA) 11: AI2 input (0–10V) 12: AI3 input (0–10V/0–20mA) 13: HDIA input (0.00–50.00kHz) 14: Value 1 set through Modbus/Modbus TCP communication (0–1000) 15: Value 2 set through Modbus/Modbus TCP communication (0–1000) 16: Value 1 set through PROFIBUS/CANopen/DeviceNet communication (0–1000)	0	<input type="radio"/>

Function code	Name	Description	Default	Modify
		17: Value 2 set through PROFIBUS/CANopen/DeviceNet communication (0–1000) 18: Value 1 set through Ethernet communication (0–1000) 19: Value 2 set through Ethernet communication (0–1000) 20: HDIB input (0.00–50.00kHz) 21: Value 1 set through EtherCAT/PROFINET/EtherNet IP communication (0–1000) 22: Torque current (Bipolar, 0–Triple the motor rated current) 23: Exciting current (Bipolar, 0–Triple the motor rated current) 24: Set frequency (Bipolar, 0–Max. output frequency) 25: Ramp reference frequency (Bipolar, 0–Max. output frequency) 26: Rotational speed (Bipolar, 0–Speed corresponding to max. output frequency) 27: Value 2 set through EtherCAT/PROFINET/EtherNet IP communication (0–1000) 28: C_AO1 from PLC (Set P27.00 to 1) (0–1000) 29: C_AO2 from PLC (Set P27.00 to 1) (0–1000) 30: Rotational speed (0–Twice the motor rated synchronous speed) 31: Output torque (Actual value, 0–Twice the motor rated torque) 32: AI/AO temperature detection output 33: Value 1 set through 216 communication (0–1000) 34: Value 2 set through 216 communication (0–1000) 35: Hook rope length (0–Max. rope length) 36–63: Reserved		
P06.17	AO1 output lower	Used to define the relationship between the	0.0%	○

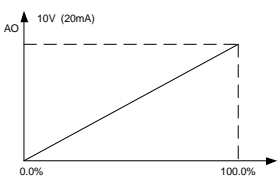
Function code	Name	Description	Default	Modify
	limit	output value and analog output. When the output value exceeds the allowed range, the output uses the lower limit or upper limit.		
P06.18	AO1 output corresponding to lower limit	When the analog output is current output, 1mA equals 0.5V.	0.00V	<input type="radio"/>
P06.19	AO1 output upper limit	In different cases, the corresponding analog output of 100% of the output value is different.	100.0%	<input type="radio"/>
P06.20	AO1 output corresponding to upper limit		10.00V	<input type="radio"/>
P06.21	AO1 output filter time	 <p>Setting range of P06.17: -300.0%–P06.19 P06.18 setting range: 0.00V–10.00V P06.19 setting range: P06.17–300.0% P06.20 setting range: 0.00V–10.00V P06.21 setting range: 0.000s–10.000s</p>	0.000s	<input type="radio"/>
P06.23	Output current setting of AO1	Applicable to P92.22=4 (using PTC for temperature measuring). Refere to section 5.18.3. Set P06.24 and P06.25 according to the selected PTC model resistance and temperature curve.	4.000	<input type="radio"/>
P06.24	PTC resistance alarm threshold		750	<input type="radio"/>
P06.25	PTC resistance alarm recovery threshold	When P06.26 is greater than P06.24, the VFD reports the alarm A-Aot and runs normally.	150	<input type="radio"/>
P06.26	Actual PTC resistance	When P06.26 is less than P06.25, the alarm A-Aot is cleared. P06.23 setting range: 0.00–20.000mA P06.24 setting range: 0–60000Ω P06.25 setting range: 0–60000Ω P06.26 setting range: 0–60000Ω	0	<input checked="" type="radio"/>
P06.27	HDO output lower limit	-300.0%– P06.29	0.00%	<input type="radio"/>
P06.28	HDO output corresponding to lower limit	0.00–50.00Hz	0.00kHz	<input type="radio"/>
P06.29	HDO output upper limit	P06.27 –300.0%	100.0%	<input type="radio"/>

Function code	Name	Description	Default	Modify
P06.30	HDO output corresponding to upper limit	0.00–50.00Hz	50.00 kHz	<input type="radio"/>
P06.31	HDO output filter time	0.000s–10.000s	0.000s	<input type="radio"/>
P06.33	Detection value for frequency being reached	0–P00.03	1.00Hz	<input type="radio"/>
P06.34	Frequency reaching detection time	0–3600.0s	0.5s	<input type="radio"/>

P07 group—Human-machine interface

Function code	Name	Description	Default	Modify
P07.00	User password	<p>0–65535</p> <p>When you set the function code to a non-zero number, password protection is enabled. If you set the function code to 00000, the previous user password is cleared and password protection is disabled.</p> <p>After the user password is set and takes effect, you cannot enter the parameter menu if you enter an incorrect password. Please remember your password and save it in a secure place.</p> <p>After you exit the function code editing interface, the password protection function is enabled within 1 minute. If password protection is enabled, "0.0.0.0" is displayed when you press the PRG/ESC key again to enter the function code editing interface. You need to enter the correct user password to enter the interface.</p> <p>Note: Restoring the default values may delete the user password. Exercise caution when using this function.</p>	0	<input type="radio"/>
P07.01	Parameter copy	<p>Range: 0–4</p> <p>0: No operation</p>	0	<input checked="" type="radio"/>

Function code	Name	Description	Default	Modify
		1: Upload parameters to the keypad 2: Download all parameters (including motor parameters) 3: Download non-motor parameters 4: Download motor parameters		
P07.02	Key function selection	Range: 0x00–0x27 Ones place: Function of QUICK/JOG 0: No function 1: Jog 2: Reserved 3: Switch between forward and reverse rotating 4: Clear the UP/DOWN setting 5: Coast to stop 6: Switch command channels in sequence 7: Reserved Tens place: Reserved	0x01	☉
P07.03	Sequence of switching running-command channels by pressing QUICK	When P07.02 =6, set the sequence of switching running-command channels by pressing this key. 0: Keypad→Terminal→Communication 1: Keypad←→Terminal 2: Keypad←→Communication 3: Terminal←→Communication	0	○
P07.04	Stop function validity of STOP/RST	Used to specify the stop function validity of STOP/RST . For fault reset, STOP/RST is valid in any conditions. 0: Valid only for keypad control 1: Valid both for keypad and terminal control 2: Valid both for keypad and communication control 3: Valid for all control modes	0	○
P07.05	Selection 1 of parameters displayed in running state	0x0000–0xFFFF	0x03FF	
P07.06	Selection 2 of parameters displayed in	0x0000–0xFFFF	0x0000	

Function code	Name	Description	Default	Modify
	running state			
P07.07	Selection of parameters displayed in stopped state	0x0000–0xFFFF	0x00FF	
P07.08	Frequency display coefficient	0.01–10.00 Display frequency = Running frequency * P07.08	1.00	○
P07.09	Rotational speed display coefficient	0.1–999.9% Mechanical rotation speed = 120 * (Displayed running frequency) * P07.09 /(Motor pole pairs)	100.0%	○
P07.10	Linear speed display coefficient	0.1–999.9% Linear speed=(Mechanical rotation speed) * P07.10	1.0%	○
P07.11	Rectifier bridge temperature	-20.0°C–120.0°C		●
P07.12	Inverter temperature	-20.0°C–120.0°C		●
P07.13	Control board software version	1.00–655.35		●
P07.14	Local accumulative running time	0–65535h		●
P07.15	VFD electricity consumption high-order bits	Used to display the electricity consumption of the VFD. VFD electricity consumption = P07.15 *1000 +		●
P07.16	VFD electricity consumption low-order bits	P07.16 P07.15 setting range: 0–65535 kWh (*1000) P07.16 setting range: 0.0–999.9 kWh		●
P07.17	VFD type	0: G type 1: P type		●
P07.18	VFD rated power	0.4–3000.0kW		●
P07.19	VFD rated voltage	50–1200V		●
P07.20	VFD rated current	0.1–6000.0A		●
P07.21	Factory bar code 1	0x0000–0xFFFF		●
P07.22	Factory bar code 2	0x0000–0xFFFF		●
P07.23	Factory bar code 3	0x0000–0xFFFF		●

Function code	Name	Description	Default	Modify
P07.24	Factory bar code 4	0x0000–0xFFFF		●
P07.25	Factory bar code 3	0x0000–0xFFFF		●
P07.26	Factory bar code 4	0x0000–0xFFFF		●
P07.27	Type of present fault	0: No fault 1: Inverter unit U-phase protection (OUt1)		●
P07.28	Last fault type	2: Inverter unit V-phase protection (OUt2)		●
P07.29	2nd-last fault type	3: Inverter unit W-phase protection (OUt3)		●
P07.30	3rd-last fault type	4: Overcurrent during acceleration (OC1)		●
P07.31	4th-last fault type	5: Overcurrent during deceleration (OC2)		●
P07.32	5th-last fault type	6: Overcurrent during constant speed running (OC3) 7: Overvoltage during acceleration (OV1) 8: Overvoltage during deceleration (OV2) 9: Overvoltage during constant speed running (OV3) 10: Bus undervoltage fault (UV) 11: Motor overload (OL1) 12: VFD overload (OL2) 13: Phase loss on input side (SPI) 14: Phase loss on output side (SPO) 15: Rectifier module overheat (OH1) 16: Inverter module overheat (OH2) 17: External fault (EF) 18: RS485 communication fault (CE) 19: Current detection fault (ItE) 20: Motor autotuning fault (tE) 21: EEPROM operation error (EEP) 22: PID feedback offline fault (PIDE) 23: Braking unit fault (bCE) 24: Running time reached (END) 25: Electronic overload (OL3) 26: Keypad communication error (PCE) 27: Parameter upload error (UPE) 28: Parameter download error (DNE) 29: PROFIBUS communication fault (E_dP) 30: Ethernet communication fault (E_NET) 31: CANopen communication fault (E-CAN) 32: To-ground short-circuit fault 1 (ETH1)		●

Function code	Name	Description	Default	Modify
		33: To-ground short-circuit fault 2 (ETH2) 34: Speed deviation fault (dEu) 35: Mal-adjustment fault (STo) 36: Underload fault (LL) 37: Encoder disconnection fault (ENC1o) 38: Encoder direction reversal fault (ENC1d) 39: Encoder Z-pulse disconnection fault (ENC1Z) 40: Safe torque off (STO) 41: Channel 1 safety circuit exception (STL1) 42: Channel 2 safety circuit exception (STL2) 43: Exception in both channels 1 and 2 (STL3) 44: Safety code FLASH CRC fault (CrCE) 45: PLC card customized fault 1 (P-E1) 46: PLC card customized fault 2 (P-E2) 47: PLC card customized fault 3 (P-E3) 48: PLC card customized fault 4 (P-E4) 49: PLC card customized fault 5 (P-E5) 50: PLC card customized fault 6 (P-E6) 51: PLC card customized fault 7 (P-E7) 52: PLC card customized fault 8 (P-E8) 53: PLC card customized fault 9 (P-E9) 54: PLC card customized fault 10 (P-E10) 55: Duplicate expansion card type (E-Err) 56: Encoder UVW lost (ENCUV) 57: PROFINET communication fault (E_PN) 58: CAN communication fault (SECAN) 59: Motor overtemperature fault (OT) 60: Failure to identify the card at slot 1 (F1-Er) 61: Failure to identify the card at slot 2 (F2-Er) 62: Failure to identify the card at slot 3 (F3-Er) 63: Communication timeout of the card at slot 1 (C1-Er) 64: Communication timeout of the card at slot 2 (C2-Er) 65: Communication timeout of the card at slot 3 (C3-Er) 66: EtherCAT communication fault (E-CAT)		

Function code	Name	Description	Default	Modify
		67: Bacnet communication fault (E-BAC) 68: DeviceNet communication fault (E-DEV) 69: CAN slave fault in master/slave synchronization (S-Err) 70: VFD disabled (dIS) 71: Contactor feedback fault (tbE) 72: Brake feedback fault (FAE) 73: Torque verification fault (tPF) 74: Operating lever zero-position fault (STC) 75: Low speed running protection fault (LSP) 76: Terminal command exception (tCE) 77: Power-on terminal command exception (POE) 78: Loose rope protection fault (SLE) 79: Brake failure (bE) 80: Master/slave position synchronization fault (ELS) 81: Analog speed reference deviation fault (AdE) 82: PT100 overtemperature (OtE1) 83: PT1000 overtemperature (OtE2) 84: Set frequency fault (SFE) 85: Current imbalance fault (Cuu) 86: PTC overtemperature fault (PtcE) 87: Overload fault (E-OvL) 88: Overspeed fault (E-OS) 89: Stalling fault (E-dS) 90: 216 communication disconnection (E-216) 91: External fault received by 216 communication card (216EF) 92: AI1 disconnected (E-AI1) 93: AI2 disconnected (E-AI2) 94: AI3 disconnected (E-AI3) 95: EtherNet IP communication timeout (E-EIP) 96: No upgrade bootloader (E-PAO)		
P07.33	Running frequency at present fault	0.00Hz~P00.03	0.00Hz	●

Function code	Name	Description	Default	Modify
P07.34	Ramp reference frequency at present fault	0.00Hz~P00.03	0.00Hz	●
P07.35	Output current at present fault	0~1200V	0V	●
P07.36	Output current at present fault	0.0~6300.0A	0.0A	●
P07.37	Bus voltage at present fault	0.0~2000.0V	0.0V	●
P07.38	Temperature at present fault	-20.0~120.0°C	0.0°C	●
P07.39	Input terminal status at present fault	0x0000~0xFFFF	0	●
P07.40	Output terminal status at present fault	0x0000~0xFFFF	0	●
P07.41	Running frequency at last fault	0.00Hz~P00.03	0.00Hz	●
P07.42	Ramp reference frequency at last fault	0.00Hz~P00.03	0.00Hz	●
P07.43	Output voltage at last fault	0~1200V	0V	●
P07.44	Output current at last fault	0.0~6300.0A	0.0A	●
P07.45	Bus voltage at last fault	0.0~2000.0V	0.0V	●
P07.46	Temperature at last fault	-20.0~120.0°C	0.0°C	●
P07.47	Input terminal status at last fault	0x0000~0xFFFF	0	●
P07.48	Output terminal status at last fault	0x0000~0xFFFF	0	●
P07.49	Running frequency at	0.00Hz~P00.03	0.00Hz	●

Function code	Name	Description	Default	Modify
	2nd-last fault			
P07.50	Ramp reference frequency at 2nd-last fault	0.00Hz–P00.03	0.00Hz	●
P07.51	Output voltage at 2nd-last fault	0–1200V	0V	●
P07.52	Output current at 2nd-last fault	0.0–6300.0A	0.0A	●
P07.53	Bus voltage at 2nd-last fault	0.0–2000.0V	0.0V	●
P07.54	Temperature at 2nd-last fault	-20.0–120.0°C	0.0°C	●
P07.55	Input terminal status at 2nd-last fault	0x0000–0xFFFF	0	●
P07.56	Output terminal status at 2nd-last fault	0x0000–0xFFFF	0	●

P08 group—Enhanced functions

Function code	Name	Description	Default	Modify
P08.00	ACC time 2	For details, see P00.11 and P00.12 . The VFD has four groups of ACC/DEC time, which can be selected by P05. The factory default ACC/DEC time of the VFD is the first group. Setting range: 0.0–3600.0s	Model depended	<input type="radio"/>
P08.01	DEC time 2		Model depended	<input type="radio"/>
P08.02	ACC time 3		Model depended	<input type="radio"/>
P08.03	DEC time 3		Model depended	<input type="radio"/>
P08.04	ACC time 4		Model depended	<input type="radio"/>
P08.05	DEC time 4		Model depended	<input type="radio"/>
P08.06	Running frequency of jog	The function code is used to define the reference frequency during jogging. Setting range: 0.00Hz– P00.03 (Max. output frequency)	5.00Hz	<input type="radio"/>

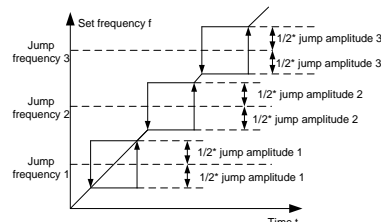
Function code	Name	Description	Default	Modify
P08.07	ACC time for jogging	ACC time for jogging means the time needed for the VFD to accelerate from 0Hz to the max. output frequency (P00.03).	Model depended	<input type="radio"/>
P08.08	DEC time for jogging	DEC time for jogging means the time needed for the VFD to decelerate from the max. output frequency (P00.03) to 0Hz. Setting range: 0.0–3600.0s	Model depended	<input type="radio"/>
P08.09	Jump frequency 1	When the set frequency is within the range of jump frequency, the VFD runs at the boundary of jump frequency. The VFD can avoid mechanical resonance points by setting jump frequencies. The VFD supports the setting of three jump frequencies. If the jump frequency points are set to 0, this function is invalid.	0.00Hz	<input type="radio"/>
P08.10	Jump frequency amplitude 1		0.00Hz	<input type="radio"/>
P08.11	Jump frequency 2		0.00Hz	<input type="radio"/>
P08.12	Jump frequency amplitude 2		0.00Hz	<input type="radio"/>
P08.13	Jump frequency 3		0.00Hz	<input type="radio"/>
P08.14	Jump frequency amplitude 3	 <p>Setting range: 0.00Hz–P00.03 (Max. output frequency)</p>	0.00Hz	<input type="radio"/>
P08.15	Amplitude of wobbling frequency	0.0–100.0% (of the set frequency)	0.0%	<input type="radio"/>
P08.16	Amplitude of sudden jump frequency	0.0–50.0% (of the amplitude of wobbling frequency)	0.0%	<input type="radio"/>
P08.17	Rise time of wobbling frequency	0.1–3600.0s	5.0s	<input type="radio"/>
P08.18	Fall time of wobbling frequency	0.1–3600.0s	5.0s	<input type="radio"/>
P08.19	Switching	0.00– P00.03 (Max. output frequency)	0.00Hz	<input type="radio"/>

Function code	Name	Description	Default	Modify
	frequency of ACC/DEC time	0.00Hz: No switchover If the running frequency is greater than P08.19 , switch to ACC/DEC time 2.		
P08.20	Frequency threshold of the start of droop control	0.00–50.00Hz	2.00Hz	<input type="radio"/>
P08.21	Reference frequency of ACC/DEC time	0: Max. output frequency 1: Set frequency 2: 100Hz Note: Valid only for straight-line ACC/DEC	0	<input checked="" type="radio"/>
P08.22	Output torque calculation method	0: Based on torque current 1: Based on output power	0	<input type="radio"/>
P08.23	Number of decimal points of frequency	0: Two 1: One	0	<input type="radio"/>
P08.24	Number of decimal points of linear speed	0: No decimal point 1: One 2: Two 3: Three	0	<input type="radio"/>
P08.25	Set counting value	P08.26 –65535	0	<input type="radio"/>
P08.26	Designated counting value	0– P08.25	0	<input type="radio"/>
P08.27	Set running time	0–65535min	0min	<input type="radio"/>
P08.28	Auto fault reset count	Auto fault reset count: When the VFD uses automatic fault reset, it is used to set the number of automatic fault reset times. When the number of continuous reset times exceeds the value, the VFD reports a fault and stops.	0	<input type="radio"/>
P08.29	Auto fault reset interval	Auto fault reset interval: Time interval from when a fault occurred to when automatic fault reset takes effect. After VFD starts, If no fault occurred within 600s after the VFD starts, the number of automatic fault reset times is cleared. P08.28 setting range: 0–10	1.0s	<input type="radio"/>

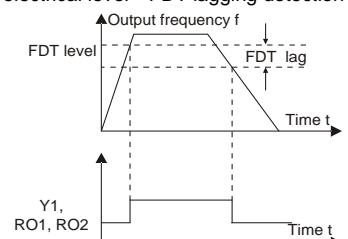
Function code	Name	Description	Default	Modify
		P08.29 setting range: 0.1–3600.0s		
P08.30	Frequency decrease ratio in drop control	The output frequency of the VFD changes as the load changes. The function code is mainly used to balance the power when several motors drive a same load. Setting range: 0.00–50.00Hz	0.00Hz	○
P08.31	Channel for switching between motor 1 and motor 3	0x00–0x15 Ones place: Switchover channel 0: Terminal 1: Modbus/Modbus TCP communication 2: PROFIBUS/CANopen/DeviceNet communication 3: Ethernet communication 4: EtherCAT/PROFINET/EtherNet IP communication 5: 216 communication Tens place: indicates whether to enable switchover during running 0: Disable 1: Enable	0x00	◎
P08.32	FDT1 electrical level detection value	When the output frequency exceeds the corresponding frequency of FDT electrical level, the multifunction digital output terminal	50.00Hz	○
P08.33	FDT1 lagging detection value	continuously outputs the signal of "Frequency level detection FDT". The signal is invalid only	5.0%	○
P08.34	FDT2 electrical level detection value	when the output frequency decreases to a value lower than the frequency corresponding to (FDT electrical level—FDT lagging detection value).	50.00Hz	○
P08.35	FDT2 lagging detection value	 <p>P08.32 setting range: 0.00Hz–P00.03 (Max. output frequency)</p>	5.0%	○

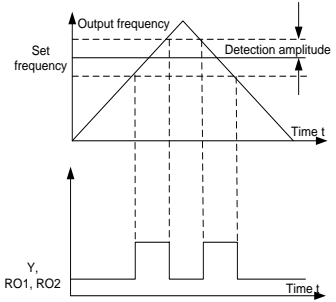
Function code	Name	Description	Default	Modify
		<p>P08.33 setting range: 0.0–100.0% (FDT1 electrical level)</p> <p>P08.34 setting range: 0.00Hz–P00.03 (Max. output frequency)</p> <p>P08.35 setting range: 0.0–100.0% (FDT2 electrical level)</p>		
P08.36	Detection value for frequency being reached	<p>When the output frequency is within the detection range, the multifunction digital output terminal outputs the signal of "Frequency reached".</p>  <p>Setting range: 0.00Hz–P00.03 (Max. output frequency)</p>	0.00Hz	○
P08.37	Enabling energy-consumption on braking	<p>0x00–0x11</p> <p>Ones place:</p> <p>0: Disable</p> <p>1: Enable</p> <p>Tens place:</p> <p>0: Disable braking short-circuit protection</p> <p>1: Enable braking short-circuit protection</p> <p>Braking short-circuit protection is disabled for 22kW and lower VFD models by default.</p> <p>Note: For the 380V models, the default value is 0x11 for 30kW (included)–110kW (included), 0x01 for <30kW, and 0x00 for >110kW.</p>	Model depended	○
P08.38	Energy-consumption braking threshold voltage	The function code is used to set the starting bus voltage of energy consumption braking. Adjust this value properly to achieve effective braking for the load. The default value varies depending	<p>For 220V: 380.0V</p> <p>For 380V: 700.0V</p>	○

Function code	Name	Description	Default	Modify
		on the voltage class. Setting range: 200.0–2000.0V	For 660V: 1120.0V	
P08.39	Cooling-fan running mode	0: The fan runs with the VFD; the fan stops 1 minute after the VFD stops. 1: Permanent running after power-on 2: Run mode 2 In addition to the running requirements in run mode 0, run mode 2 has the feature that the fan still runs even when the ramp frequency is greater than 0	0	○
P08.40	PWM selection	0x0000–0x1121 Ones place: PWM mode selection 0: PWM mode 1, 3PH modulation and 2PH modulation 1: PWM mode 2, 3PH modulation Tens place: PWM low-speed carrier frequency limit 0: Low-speed carrier frequency limit mode 1 1: Low-speed carrier frequency limit mode 2 2: No limit on low-speed carrier frequency Hundreds place: Deadzone compensation method 0: Compensation method 1 1: Compensation method 2 Thousands place: PWM loading mode selection 0: Interruptive loading 1: Normal loading	0x1101	◎
P08.41	Overmodulation selection	0x00–0x1111 Ones place: 0: Disable 1: Enable Tens place 0: Mild overmodulation 1: Deepened overmodulation Hundreds: Carrier frequency limit 0:Yes 1:No Thousands: Output voltage compensation	0x1001	◎

Function code	Name	Description	Default	Modify
		0: No 1: Yes		
P08.42	LED keypad digit control setting	0x000–0x1223 Ones place: Frequency adjustment selection 0: Both the \wedge/\vee key and potentiometer are valid for adjustment. 1: Only the \wedge/\vee key is valid for adjustment. 2: Only the potentiometer is valid for adjustment. 3: Neither the \wedge/\vee key nor the potentiometer is valid for adjustment. Tens place: Frequency control validity 0: Only valid when P00.06=0 or P00.07=0 1: Valid for all frequency setting manners 2: Invalid for multi-step speed when multi-step speed has the priority Hundreds place: Action selection during stop 0: Setting is valid 1: Valid during running, cleared after stop 2: Valid during running, cleared after receiving the stop command Thousands place: Integral function of the \wedge/\vee key and potentiometer 0: The integral function is valid 1: The integral function is invalid	0x0003	<input type="radio"/>
P08.43	LED keypad digital potentiometer integral rate	0.01–10.00s	0.10s	<input type="radio"/>
P08.44	UP/DOWN terminal control setting	0x000–0x221 Ones place: Frequency setting selection 0: The setting made through UP/DOWN is valid. 1: The setting made through UP/DOWN is invalid. Tens place: Frequency control selection 0: Valid only when P00.06=0 or P00.07=0 1: Valid for all frequency setting methods 2: Invalid for multi-step speed running when	0x000	<input type="radio"/>

Function code	Name	Description	Default	Modify
		multi-step speed running has the priority Hundreds place: Action selection for stop 0: Setting is valid. 1: Valid during running, cleared after stop 2: Valid during running, cleared after a stop command is received		
P08.45	Frequency increment integral rate of the UP terminal	0.01–50.00Hz/s	0.50Hz/s	<input type="radio"/>
P08.46	Frequency integral rate of the DOWN terminal	0.01–50.00Hz/s	0.50Hz/s	<input type="radio"/>
P08.47	Action selection at power-off during frequency setting	0x000–0x111 Ones place: Action selection at power-off during frequency adjusting through digitals. 0: Save the setting at power-off. 1: Clear the setting at power-off. Action selection at power-off during frequency adjusting through Modbus/Modbus TCP communication 0: Save the setting at power-off. 1: Clear the setting at power-off. Hundreds place: Action selection at power-off during frequency adjusting through DP communication methods 0: Save the setting at power-off. 1: Clear the setting at power-off.	0x000	<input type="radio"/>
P08.48	Initial electricity consumption high-order bits	Used to set the initial electricity consumption. Initial electricity consumption = P08.48 *1000 + P08.49	0 kWh	<input type="radio"/>
P08.49	Initial electricity consumption low-order bits	P08.48 setting range: 0–59999 kWh (k) P08.49 setting range: 0.0–999.9 kWh	0.0 kWh	<input type="radio"/>
P08.50	Magnetic flux braking	Used to enable magnetic flux braking. 0: Disable 100–150: A larger coefficient indicates stronger braking.	0	<input type="radio"/>

Function code	Name	Description	Default	Modify
		<p>The VFD can quickly slow down the motor by increasing the magnetic flux. The energy generated by the motor during braking can be transformed into heat energy by increasing the magnetic flux.</p> <p>The VFD monitors the state of the motor continuously even during the magnetic flux period. Magnetic flux braking can be used for motor stop, as well as for motor rotation speed change. The other advantages include: Braking is performed immediately after the stop command is given. The braking can be started without waiting for magnetic flux weakening. The cooling is better. The current of the stator other than the rotor increases during magnetic flux braking, while the cooling of the stator is more effective than the rotor.</p>		
P08.51	VFD input power factor	This function code is used to adjust the current display value on the AC input side. 0.00–1.00	0.56	<input type="radio"/>
P08.52	STO lock selection	0: Lock upon STO alarm Lock upon STO alarm indicates resetting is required after state restoration if STO occurs. 1: No lock on STO alarm No lock on STO alarm indicates STO alarm disappears automatically after state restoration if STO occurs.	0	<input type="radio"/>
P08.53	Upper limit frequency bias value in torque control	0.00 Hz– P00.03 (Max. output frequency) Note: Valid only for torque control.	0.00Hz	<input type="radio"/>
P08.54	Upper limit frequency ACC/DEC selection in torque control	0: No limit on acceleration or deceleration 1: ACC/DEC time 1 2: ACC/DEC time 2 3: ACC/DEC time 3 4: ACC/DEC time 4	0	<input type="radio"/>
P08.55	Enabling auto carrier frequency	0: Disable 1: Enable	0	<input type="radio"/>

Function code	Name	Description	Default	Modify
	reduction	Note: Automatic carrier frequency reduction indicates that the VFD automatically reduces the carrier frequency when detecting the heat sink temperature exceeds the rated temperature. When the temperature decreases to a certain degree, the carrier frequency recovers. This function reduces the chance of VFD overheat alarm.		
P08.56	Min. carrier frequency	1.0–15.0kHz	Model dependent	●
P08.57	Temperature point of auto carrier frequency reduction	40.0–85.0°C	70.0°C	○
P08.58	Interval of carrier frequency reduction	0–30(min)	10	○
P08.59	AI1 disconnection detection threshold	0–100%	0	○
P08.60	AI2 disconnection detection threshold	0–100%	0	○
P08.61	AI3 disconnection detection threshold	0–100%	0	○
P08.62	Output current filter time	0.000–10.000s	0.000	○
P08.63	Output torque filter times	0–8	8	○

P09 group— PID control

Function code	Name	Description	Default	Modify
P09.00	PID reference source	When frequency command selection (P00.06 , P00.07) is 7, or channel of voltage setup	0	○

Function code	Name	Description	Default	Modify
		<p>(P04.27) is 6, the running mode of VFD is process PID control. The function code determines the target given channel during the PID process. 0: Set by P09.01 1: AI1 2: AI2 3: AI3 4: High-speed pulse HDIA 5: Multi-step running 6: Modbus/Modbus TCP communication 7: PROFIBUS/CANopen/DeviceNet communication 8: Ethernet communication 9: High-speed pulse HDIB 10: EtherCAT/PROFINET/EtherNet IP communication 11: Programmable expansion card 12: 216 communication</p> <p>The set target of process PID is a relative value, for which 100% equals 100% of the feedback signal of the controlled system. The system always performs calculation by using a relative value (0–100.0%).</p>		
P09.01	PID digital setting	<p>The function code is mandatory when P09.00=0. The base value of The function code is the feedback of the system. Setting range: -100.0%–100.0%</p>	0.0%	○
P09.02	PID feedback source	<p>Used to select PID feedback channel. 0: AI1 1: AI2 2: AI3 3: High-speed pulse HDIA 4: Modbus/Modbus TCP communication 5: PROFIBUS/CANopen/DeviceNet communication 6: Ethernet communication 7: High-speed pulse HDIB</p>	0	○

Function code	Name	Description	Default	Modify
		8: EtherCAT/PROFINET/EtherNet IP communication 9: Programmable expansion card 10: Reserved 11: 216 communication Note: The reference channel and feedback channel cannot be duplicate. Otherwise, effective PID control cannot be achieved.		
P09.03	PID output characteristics selection	0: PID output is positive. When the feedback signal is greater than the PID reference value, the output frequency of the VFD will decrease to balance the PID. Example: PID control on strain during unwinding. 1: PID output is negative. When the feedback signal is greater than the PID reference value, the output frequency of the VFD will increase to balance the PID. Example: PID control on strain during unwinding.	0	<input type="radio"/>
P09.04	Proportional gain (Kp)	The function is applied to the proportional gain P of PID input. P determines the strength of the whole PID adjuster. The value 100 indicates that when the difference between the PID feedback value and given value is 100%, the range within which the PID regulator can regulate the output frequency command is the max. frequency (ignoring integral function and differential function). Setting range: 0.00–100.00	1.80	<input type="radio"/>
P09.05	Integral time (Ti)	Used to determine the speed of the integral adjustment on the deviation of PID feedback and reference from the PID regulator. When the deviation of PID feedback and reference is 100%, the integral adjuster works continuously during the time (ignoring proportional and differential function) to achieve the max. output frequency (P00.03) or the max. voltage (P04.31). Shorter integral time indicates stronger adjustment.	0.90s	<input type="radio"/>

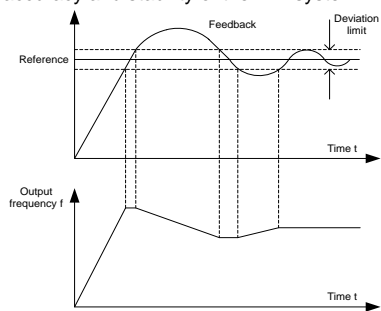
Function code	Name	Description	Default	Modify
		Setting range: 0.00–10.00s		
P09.06	Differential time (Td)	Used to determine the strength of the change ratio adjustment on the deviation of PID feedback and reference from the PID regulator. If the PID feedback changes 100% during the time, the adjustment of the differential regulator (ignoring proportional and integral function) is the max. output frequency (P00.03) or the max. voltage (P04.31). Longer differential time indicates stronger adjustment. Setting range: 0.00–10.00s	0.00s	<input type="radio"/>
P09.07	Sampling cycle (T)	Used to indicate the sampling cycle of feedback. The regulator calculates in each sampling cycle. A longer sampling cycle indicates slower response. Setting range: 0.001–10.000s	0.001s	<input type="radio"/>
P09.08	PID control deviation limit	The output of the PID system is relative to the max. deviation of the closed loop reference. As shown in the following figure, the PID regulator stops regulating in the range of deviation limit. Set the function parameter properly to adjust the accuracy and stability of the PID system.  Setting range: 0.0–100.0%	0.0%	<input type="radio"/>
P09.09	PID output upper limit	The function codes are used to set the upper and lower limits of PID regulator output values.	100.0%	<input type="radio"/>
P09.10	PID output lower limit	100.0% corresponds to the max. output frequency (P00.03) or max. voltage (P04.31). P09.09 setting range: P09.10—100.0%	0.0%	<input type="radio"/>

Function code	Name	Description	Default	Modify
		Setting range of P09.10 : -100.0%– P09.09		
P09.11	Feedback offline detection value	Used to set the PID feedback offline detection value. When the feedback value is smaller than or equal to the feedback offline detection value, and the duration exceeds the value specified by P09.12 , the VFD reports "PID feedback offline fault" and the keypad displays PIDE.	0.0%	<input type="radio"/>
P09.12	Feedback offline detection time	<p>P09.11 setting range: 0.0–100.0% P09.12 setting range: 0.0–3600.0s</p>	1.0s	<input type="radio"/>
P09.13	PID control selection	0x0000–0x1111 Ones place: 0: Continue integral control after the frequency reaches upper/lower limit 1: Stop integral control after the frequency reaches upper/lower limit Tens place: 0: Same as the main reference direction 1: Contrary to the main reference direction Hundreds place: 0: Limit as per the max. frequency 1: Limit as per A frequency Thousands place: 0: A+B frequency. ACC/DEC of main reference A frequency source buffering is invalid. 1: A+B frequency. ACC/DEC of main reference A frequency source buffering is valid. The ACC/DEC is determined by P08.04 (ACC time 4).	0x0001	<input type="radio"/>
P09.14	Low frequency proportional gain (Kp)	0.00–100.00 Low-frequency switching point: 5.00Hz, high-frequency switching point: 10.00Hz	1.00	<input type="radio"/>

Function code	Name	Description	Default	Modify
		(P09.04 corresponds to high-frequency parameter), and the middle is the linear interpolation between these two points.		
P09.15	ACC/DEC time of PID command	0.0–1000.0s	0.0s	<input type="radio"/>
P09.16	PID output filter time	0.000–10.000s	0.000s	<input type="radio"/>
P09.18	Low frequency integral time	0.00–10.00s	0.90s	<input type="radio"/>
P09.19	Low frequency differential time	0.00–10.00s	0.00s	<input type="radio"/>
P09.20	Low frequency point for PID parameter switching	0–P09.21	5.00Hz	<input type="radio"/>
P09.21	High frequency point for PID parameter switching	P09.20–P00.03	10.00Hz	<input type="radio"/>

P10 group—Simple PLC and multi-step speed control

Function code	Name	Description	Default	Modify
P10.00	Simple PLC mode	0: Stop after running once. The VFD stops automatically after running for one cycle, and it can be started only after receiving the running command. 1: Keep running in the final value after running for one cycle. The VFD keeps the running frequency and direction of the last section after a single cycle. 2: Cyclic running. The VFD enters the next cycle after completing one cycle until receiving the stop command.	0	<input type="radio"/>
P10.01	Simple PLC memory selection	0: No power-failure memory 1: Memory after power-off. The PLC memories its running stage and running frequency before power-off.	0	<input type="radio"/>

Function code	Name	Description	Default	Modify
P10.02	Multi-step speed 0	<p>Frequency setting range for steps from step 0 to step 15: -100.0–100.0%. 100.0% corresponds to the max. output frequency P00.03.</p> <p>Running time setting range for steps from step 0 to step 15: 0.0–6553.5s(min). The time unit is specified by P10.37.</p> <p>When simple PLC operation is selected, set P10.02–P10.33 to determine the running frequency and running time of each step.</p> <p>Note: The symbol of multi-step speed determines the running direction of simple PLC, and the negative value means reverse running.</p>	0.0%	<input type="radio"/>
P10.03	Running time of step 0		0.0s (min)	<input type="radio"/>
P10.04	Multi-step speed 1		0.0%	<input type="radio"/>
P10.05	Running time of step 1		0.0s (min)	<input type="radio"/>
P10.06	Multi-step speed 2		0.0%	<input type="radio"/>
P10.07	Running time of step 2		0.0s (min)	<input type="radio"/>
P10.08	Multi-step speed 3		0.0%	<input type="radio"/>
P10.09	Running time of step 3		0.0s (min)	<input type="radio"/>
P10.10	Multi-step speed 4		0.0%	<input type="radio"/>
P10.11	Running time of step 4		0.0s (min)	<input type="radio"/>
P10.12	Multi-step speed 5		0.0%	<input type="radio"/>
P10.13	Running time of step 5		0.0s (min)	<input type="radio"/>
P10.14	Multi-step speed 6		0.0%	<input type="radio"/>
P10.15	Running time of step 6		0.0s (min)	<input type="radio"/>
P10.16	Multi-step speed 7		0.0%	<input type="radio"/>
P10.17	Running time of step 7	When selecting multi-step speed running, the multi-step speed is within the range of -fmax–fmax, and it can be set continuously. The start/stop of multi-step stop running is also determined by P00.01 .	0.0s (min)	<input type="radio"/>
P10.18	Multi-step speed 8	0.0%	<input type="radio"/>	
P10.19	Running time of step 8	0.0s (min)	<input type="radio"/>	
P10.20	Multi-step speed 9	0.0%	<input type="radio"/>	
P10.21	Running time of step 9	The VFD supports the setting of 16-step speed, which are set by combined codes of multi-step terminals 1–4 set by S terminals, corresponding to function codes P05.01–P05.06 and correspond to multi-step speeds 0 to 15.	0.0s (min)	<input type="radio"/>
P10.22	Multi-step speed 10	0.0%	<input type="radio"/>	
P10.23	Running time of step 10	0.0s (min)	<input type="radio"/>	
P10.24	Multi-step speed 11	0.0%	<input type="radio"/>	
P10.25	Running time of	0.0s (min)	<input type="radio"/>	

Function code	Name	Description	Default	Modify																																																																																										
	step 11	<p>When terminals 1–4 are OFF, the frequency input mode is set by P00.06 or P00.07. When terminals 1–4 are not all OFF, the frequency set by multi-step speed will prevail, and the priority of multi-step setting is higher than that of the keypad, analog, high-speed pulse, PID, and communication.</p> <p>Mapping between terminals and multi-step speed (T indicates terminal):</p> <table border="1"> <tr><td>Trml 1</td><td>OFF</td><td>ON</td><td>OFF</td><td>ON</td><td>OFF</td><td>ON</td><td>OFF</td><td>ON</td></tr> <tr><td>Trml 2</td><td>OFF</td><td>OFF</td><td>ON</td><td>ON</td><td>OFF</td><td>OFF</td><td>ON</td><td>ON</td></tr> <tr><td>Trml 3</td><td>OFF</td><td>OFF</td><td>OFF</td><td>OFF</td><td>ON</td><td>ON</td><td>ON</td><td>ON</td></tr> <tr><td>Trml 4</td><td>OFF</td><td>OFF</td><td>OFF</td><td>OFF</td><td>OFF</td><td>OFF</td><td>OFF</td><td>OFF</td></tr> <tr><td>Step</td><td>0</td><td>1</td><td>2</td><td>3</td><td>4</td><td>5</td><td>6</td><td>7</td></tr> <tr><td>Trml 1</td><td>OFF</td><td>ON</td><td>OFF</td><td>ON</td><td>OFF</td><td>ON</td><td>OFF</td><td>ON</td></tr> <tr><td>Trml 2</td><td>OFF</td><td>OFF</td><td>ON</td><td>ON</td><td>OFF</td><td>OFF</td><td>ON</td><td>ON</td></tr> <tr><td>Trml 3</td><td>OFF</td><td>OFF</td><td>OFF</td><td>OFF</td><td>ON</td><td>ON</td><td>ON</td><td>ON</td></tr> <tr><td>Trml 4</td><td>ON</td><td>ON</td><td>ON</td><td>ON</td><td>ON</td><td>ON</td><td>ON</td><td>ON</td></tr> <tr><td>Step</td><td>8</td><td>9</td><td>10</td><td>11</td><td>12</td><td>13</td><td>14</td><td>15</td></tr> </table>	Trml 1	OFF	ON	OFF	ON	OFF	ON	OFF	ON	Trml 2	OFF	OFF	ON	ON	OFF	OFF	ON	ON	Trml 3	OFF	OFF	OFF	OFF	ON	ON	ON	ON	Trml 4	OFF	OFF	OFF	OFF	OFF	OFF	OFF	OFF	Step	0	1	2	3	4	5	6	7	Trml 1	OFF	ON	OFF	ON	OFF	ON	OFF	ON	Trml 2	OFF	OFF	ON	ON	OFF	OFF	ON	ON	Trml 3	OFF	OFF	OFF	OFF	ON	ON	ON	ON	Trml 4	ON	ON	ON	ON	ON	ON	ON	ON	Step	8	9	10	11	12	13	14	15	0.0%	<input type="radio"/>
Trml 1	OFF		ON	OFF	ON	OFF	ON	OFF	ON																																																																																					
Trml 2	OFF		OFF	ON	ON	OFF	OFF	ON	ON																																																																																					
Trml 3	OFF		OFF	OFF	OFF	ON	ON	ON	ON																																																																																					
Trml 4	OFF		OFF	OFF	OFF	OFF	OFF	OFF	OFF																																																																																					
Step	0		1	2	3	4	5	6	7																																																																																					
Trml 1	OFF		ON	OFF	ON	OFF	ON	OFF	ON																																																																																					
Trml 2	OFF		OFF	ON	ON	OFF	OFF	ON	ON																																																																																					
Trml 3	OFF	OFF	OFF	OFF	ON	ON	ON	ON																																																																																						
Trml 4	ON	ON	ON	ON	ON	ON	ON	ON																																																																																						
Step	8	9	10	11	12	13	14	15																																																																																						
P10.26	Multi-step speed 12		0.0%	<input type="radio"/>																																																																																										
P10.27	Running time of step 12		0.0s (min)	<input type="radio"/>																																																																																										
P10.28	Multi-step speed 13		0.0%	<input type="radio"/>																																																																																										
P10.29	Running time of step 13		0.0s (min)	<input type="radio"/>																																																																																										
P10.30	Multi-step speed 14		0.0%	<input type="radio"/>																																																																																										
P10.31	Running time of step 14		0.0s (min)	<input type="radio"/>																																																																																										
P10.32	Multi-step speed 15		0.0%	<input type="radio"/>																																																																																										
P10.33	Running time of step 15		0.0s (min)	<input type="radio"/>																																																																																										
P10.34	ACC/DEC time of steps 0–7 of simple PLC	<table border="1"> <thead> <tr> <th>Code</th> <th>Binary</th> <th>Step</th> <th>ACC/DEC T1</th> <th>ACC/DEC T2</th> <th>ACC/DEC T3</th> <th>ACC/DEC T4</th> </tr> </thead> <tbody> <tr> <td>BIT1</td> <td>BIT0</td> <td>0</td> <td>00</td> <td>01</td> <td>10</td> <td>11</td> </tr> <tr> <td>BIT3</td> <td>BIT2</td> <td>1</td> <td>00</td> <td>01</td> <td>10</td> <td>11</td> </tr> <tr> <td>BIT5</td> <td>BIT4</td> <td>2</td> <td>00</td> <td>01</td> <td>10</td> <td>11</td> </tr> <tr> <td>BIT7</td> <td>BIT6</td> <td>3</td> <td>00</td> <td>01</td> <td>10</td> <td>11</td> </tr> <tr> <td>BIT9</td> <td>BIT8</td> <td>4</td> <td>00</td> <td>01</td> <td>10</td> <td>11</td> </tr> <tr> <td>BIT11</td> <td>BIT10</td> <td>5</td> <td>00</td> <td>01</td> <td>10</td> <td>11</td> </tr> <tr> <td>BIT13</td> <td>BIT12</td> <td>6</td> <td>00</td> <td>01</td> <td>10</td> <td>11</td> </tr> </tbody> </table>	Code	Binary	Step	ACC/DEC T1	ACC/DEC T2	ACC/DEC T3	ACC/DEC T4	BIT1	BIT0	0	00	01	10	11	BIT3	BIT2	1	00	01	10	11	BIT5	BIT4	2	00	01	10	11	BIT7	BIT6	3	00	01	10	11	BIT9	BIT8	4	00	01	10	11	BIT11	BIT10	5	00	01	10	11	BIT13	BIT12	6	00	01	10	11	0x0000	<input type="radio"/>																																		
Code	Binary	Step	ACC/DEC T1	ACC/DEC T2	ACC/DEC T3	ACC/DEC T4																																																																																								
BIT1	BIT0	0	00	01	10	11																																																																																								
BIT3	BIT2	1	00	01	10	11																																																																																								
BIT5	BIT4	2	00	01	10	11																																																																																								
BIT7	BIT6	3	00	01	10	11																																																																																								
BIT9	BIT8	4	00	01	10	11																																																																																								
BIT11	BIT10	5	00	01	10	11																																																																																								
BIT13	BIT12	6	00	01	10	11																																																																																								
P10.35	ACC/DEC time of steps 8–15 of simple PLC	<p>P10.34</p> <table border="1"> <tbody> <tr> <td>BIT1</td> <td>BIT0</td> <td>0</td> <td>00</td> <td>01</td> <td>10</td> <td>11</td> </tr> <tr> <td>BIT3</td> <td>BIT2</td> <td>1</td> <td>00</td> <td>01</td> <td>10</td> <td>11</td> </tr> <tr> <td>BIT5</td> <td>BIT4</td> <td>2</td> <td>00</td> <td>01</td> <td>10</td> <td>11</td> </tr> <tr> <td>BIT7</td> <td>BIT6</td> <td>3</td> <td>00</td> <td>01</td> <td>10</td> <td>11</td> </tr> <tr> <td>BIT9</td> <td>BIT8</td> <td>4</td> <td>00</td> <td>01</td> <td>10</td> <td>11</td> </tr> <tr> <td>BIT11</td> <td>BIT10</td> <td>5</td> <td>00</td> <td>01</td> <td>10</td> <td>11</td> </tr> <tr> <td>BIT13</td> <td>BIT12</td> <td>6</td> <td>00</td> <td>01</td> <td>10</td> <td>11</td> </tr> </tbody> </table>	BIT1	BIT0	0	00	01	10	11	BIT3	BIT2	1	00	01	10	11	BIT5	BIT4	2	00	01	10	11	BIT7	BIT6	3	00	01	10	11	BIT9	BIT8	4	00	01	10	11	BIT11	BIT10	5	00	01	10	11	BIT13	BIT12	6	00	01	10	11	0x0000	<input type="radio"/>																																									
BIT1	BIT0	0	00	01	10	11																																																																																								
BIT3	BIT2	1	00	01	10	11																																																																																								
BIT5	BIT4	2	00	01	10	11																																																																																								
BIT7	BIT6	3	00	01	10	11																																																																																								
BIT9	BIT8	4	00	01	10	11																																																																																								
BIT11	BIT10	5	00	01	10	11																																																																																								
BIT13	BIT12	6	00	01	10	11																																																																																								

Function code	Name	Description	Default	Modify																																																															
		<table border="1"> <tr> <td>BIT15</td> <td>BIT14</td> <td>7</td> <td>00</td> <td>01</td> <td>10</td> <td>11</td> </tr> <tr> <td>BIT11</td> <td>BIT10</td> <td>8</td> <td>00</td> <td>01</td> <td>10</td> <td>11</td> </tr> <tr> <td>BIT9</td> <td>BIT8</td> <td>9</td> <td>00</td> <td>01</td> <td>10</td> <td>11</td> </tr> <tr> <td>BIT5</td> <td>BIT4</td> <td>10</td> <td>00</td> <td>01</td> <td>10</td> <td>11</td> </tr> <tr> <td>BIT7</td> <td>BIT6</td> <td>11</td> <td>00</td> <td>01</td> <td>10</td> <td>11</td> </tr> <tr> <td>BIT9</td> <td>BIT8</td> <td>12</td> <td>00</td> <td>01</td> <td>10</td> <td>11</td> </tr> <tr> <td>BIT11</td> <td>BIT10</td> <td>13</td> <td>00</td> <td>01</td> <td>10</td> <td>11</td> </tr> <tr> <td>BIT13</td> <td>BIT12</td> <td>14</td> <td>00</td> <td>01</td> <td>10</td> <td>11</td> </tr> <tr> <td>BIT15</td> <td>BIT14</td> <td>15</td> <td>00</td> <td>01</td> <td>10</td> <td>11</td> </tr> </table> <p>Select corresponding acceleration/deceleration time, and then convert 16-bit binary number into hexadecimal number, finally, and then set corresponding function codes. ACC/DEC time 1 is set by P00.11 and P00.12; ACC/DEC time 2 is set by P08.00 and P08.01; ACC/DEC time 3 is set by P08.02 and P08.03; ACC/DEC time 4 is set by P08.04 and P08.05. Setting range: 0x0000 –0xFFFF</p>	BIT15	BIT14	7	00	01	10	11	BIT11	BIT10	8	00	01	10	11	BIT9	BIT8	9	00	01	10	11	BIT5	BIT4	10	00	01	10	11	BIT7	BIT6	11	00	01	10	11	BIT9	BIT8	12	00	01	10	11	BIT11	BIT10	13	00	01	10	11	BIT13	BIT12	14	00	01	10	11	BIT15	BIT14	15	00	01	10	11		
BIT15	BIT14	7	00	01	10	11																																																													
BIT11	BIT10	8	00	01	10	11																																																													
BIT9	BIT8	9	00	01	10	11																																																													
BIT5	BIT4	10	00	01	10	11																																																													
BIT7	BIT6	11	00	01	10	11																																																													
BIT9	BIT8	12	00	01	10	11																																																													
BIT11	BIT10	13	00	01	10	11																																																													
BIT13	BIT12	14	00	01	10	11																																																													
BIT15	BIT14	15	00	01	10	11																																																													
P10.36	PLC restart mode	<p>0: Restart from the first step, namely if the VFD stops during running (caused by stop command, fault or power down), it will run from the first step after restart.</p> <p>1: Continue running from the step frequency when interruption occurred, namely if the VFD stops during running (caused by stop command or fault), it will record the running time of current step, and enters this step automatically after restart, then continue running at the frequency defined by this step in the remaining time.</p>	0	⊙																																																															
P10.37	Multi-step time unit	<p>0: second; the running time of each step is counted in seconds</p> <p>1: minute; the running time of each step is counted in minutes</p>	0	⊙																																																															

P11 group—Protection parameters

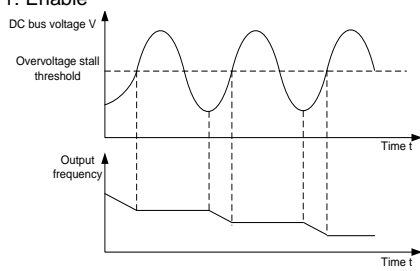
Function code	Name	Description	Default	Modify
P11.00	Protection against phase loss	0x000–0x1111 Ones place: Reserved Tens place: 0: Disable output phase loss protection. 1: Enable output phase loss protection. Hundreds place: 0: Disable hardware input phase loss protection. 1: Enable hardware input phase loss protection. Thousands place: 0: During stop, if a hardware input phase loss fault occurs, it reports SPI. 1: During stop, if a hardware input phase loss fault occurs, it reports A-SPI.	Model depended	<input type="radio"/>
P11.01	Frequency drop at transient power-off	0: Disable 1: Enable	0	<input type="radio"/>
P11.02	Enabling energy-consumption on braking for stop	0: Enable 1: Disable	0	<input checked="" type="radio"/>
P11.03	Overvoltage stalling protection	0: Disable 1: Enable  Note: It can be modified only when P11.26 is 1 indicating special functions are enabled.	0	<input type="radio"/>
P11.04	Overvoltage stalling protection voltage	120–150% (standard bus voltage) (380V)	136%	<input type="radio"/>
		120–150% (standard bus voltage) (220V)	120%	
P11.05	Current limit mode	During accelerated running, as the load is too	10	<input checked="" type="radio"/>

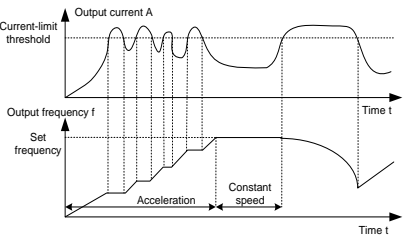
Function code	Name	Description	Default	Modify
		<p>large, the actual acceleration rate of motor is lower than that of output frequency, if no measures are taken, the VFD may trip due to overcurrent during acceleration. 0x00–0x21 Ones place: Hardware and software current-limit action selection 0: Invalid 1: Always valid Tens: Hardware current limit overload alarm selection 0: OL2 is valid. 1: OL2 is invalid. 2: Reserved Note: It can be modified only when P11.26 is 1 indicating special functions are enabled.</p>		
P11.06	Automatic current limit threshold	Current-limit protection function detects output current during running, and compares it with the current-limit level defined by P11.06 , if it	250.0%	☉
P11.07	Frequency drop rate during current limit	<p>if it exceeds the current-limit level, the VFD will run at stable frequency during accelerated running, or run in decreased frequency during constant-speed running; if it exceeds the current-limit level continuously, the VFD output frequency will drop continuously until reaching lower limit frequency. When the output current is detected to be lower than the current-limit level again, it will continue accelerated running.</p>  <p>P11.06 setting range: 50.0–250.0% (of the rated VFD output current)</p>	10.00 Hz/s	☉

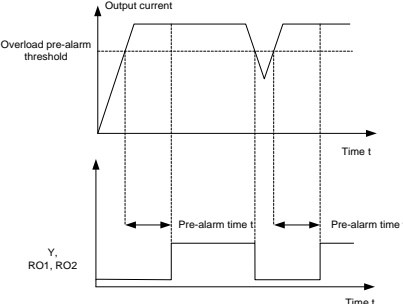
Function code	Name	Description	Default	Modify
		P11.07 setting range: 0.00–50.00Hz/s		
P11.08	VFD/motor OL/UL pre-alarm selection	If the VFD or motor output current is larger than the overload pre-alarm detection level (P11.09), and the duration exceeds the overload pre-alarm detection time (P11.10), overload pre-alarm signal will be outputted.	0x0000	<input type="radio"/>
P11.09	Overload pre-alarm detection level		150%	<input type="radio"/>
P11.10	Overload pre-alarm detection time	 <p>P11.08 setting range: Enable and define overload pre-alarm function of the VFD and motor. Setting range: 0x0000 –0x1132 Ones place: 0: Motor OL/UL pre-alarm, relative to motor rated current. 1: VFD OL/UL pre-alarm, relative to VFD rated output current. 2: Motor output torque overload/underload pre-alarm, relative to motor rated torque. Tens place: 0: The VFD continues to work for an OL/UL alarm. 1: The VFD continues to work for a UL alarm but stops running for an OL fault. 2: The VFD continues to work for an OL alarm but stops running for a UL fault. 3: The VFD stops running for an OL/UL alarm. Hundreds place: 0: Detect all the time. 1: Detect during constant speed running.</p>	1.00s	<input type="radio"/>

Function code	Name	Description	Default	Modify
		Thousands place: VFD overload current reference selection 0: Related to current calibration coefficient 1: Irrelated to current calibration coefficient P11.09 setting range: P11.11 –200% (relative value determined by the ones place of P11.08) P11.10 setting range: 0.01–3600.00s		
P11.11	Underload pre-alarm detection threshold	Underload pre-alarm signal will be outputted if the output current of the VFD or motor is lower than underload pre-alarm detection level (P11.11), and the duration exceeds underload pre-alarm detection time (P11.12).	25%	<input type="radio"/>
P11.12	Underload pre-alarm detection time	P11.11 setting range: 0– P11.09 (relative value determined by the ones place of P11.08) Setting range of P11.12 : 0.01–360.00s	0.05s	<input type="radio"/>
P11.13	Fault output terminal action upon fault occurring	Used to set the action of fault output terminals at undervoltage and fault reset. 0x00–0x11 Ones place: 0: Act upon an undervoltage fault 1: Do not act upon an undervoltage fault Tens place: 0: Act during automatic reset 1: Do not act during the automatic reset period	0x00	<input type="radio"/>
P11.14	Speed deviation detection value	0.0–50.0% Used to set the speed deviation detection value.	10.0%	<input type="radio"/>
P11.15	Speed deviation detection time	Used to set the speed deviation detection time. If P11.14 is set to a non-zero value, and the speed deviation is greater than the value of P11.14, which lasts the time specified by P11.15, the speed deviation fault dEu is reported. Note: Speed deviation protection is invalid when P11.15=0.0.	2.0s	<input type="radio"/>

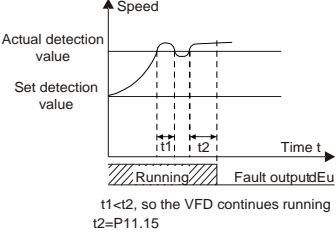
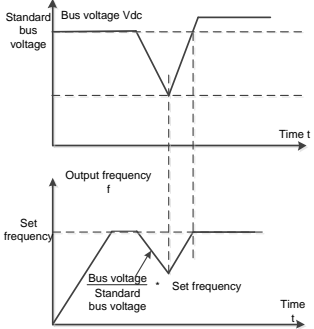
Function code	Name	Description	Default	Modify
		 <p>t1 < t2, so the VFD continues running t2=P11.15</p> <p>Setting range: 0.0–10.0s</p>		
P11.16	Automatic frequency-reduction during voltage drop	<p>0–1 0: Disable 1: Enable</p> 	0	○
P11.17	Proportional coefficient of voltage regulator during undervoltage stall	Used to set the proportional coefficient of the bus voltage regulator during undervoltage stall. Setting range: 0–1000	100	○
P11.18	Proportional coefficient of voltage regulator during undervoltage stall	Used to set the integral coefficient of the bus voltage regulator during undervoltage stall. Setting range: 0–1000	40	○
P11.19	Proportional coefficient of current regulator during undervoltage stall	Used to set the proportional coefficient of the active current regulator during undervoltage stall. Setting range: 0–1000	25	○

Function code	Name	Description	Default	Modify
P11.20	Integral coefficient of current regulator during undervoltage stall	Used to set the integral coefficient of the active current regulator during undervoltage stall. Setting range: 0–2000	150	<input type="radio"/>
P11.21	Proportional coefficient of voltage regulator during overvoltage stall	Used to set the proportional coefficient of the bus voltage regulator during overvoltage stall. Setting range: 0–1000	60	<input type="radio"/>
P11.22	Integral coefficient of voltage regulator during overvoltage stall	This parameter is used to set the integral coefficient of the bus voltage regulator during overvoltage stall. Setting range: 0–1000	10	<input type="radio"/>
P11.23	Proportional coefficient of current regulator during overvoltage stall	This parameter is used to set the proportional coefficient of the active current regulator during overvoltage stall. Setting range: 0–1000	60	<input type="radio"/>
P11.24	Integral coefficient of current regulator during overvoltage stall	This parameter is used to set the integral coefficient of the active current regulator during overvoltage stall. Setting range: 0–2000	250	<input type="radio"/>
P11.25	Enable VFD overload integral	0: Disable 1: Enable When this parameter is set to 0, the overload timing value P17.48 is reset to zero after the VFD is stopped. In this case, the determination of VFD overload takes more time, and therefore the effective protection over the VFD is weakened. When this parameter is set to 1, the overload timing value P17.48 is not reset, and the overload timing value is accumulative. In this case, the determination of VFD overload takes less time, and therefore the protection over the VFD can be performed more quickly. VFD overload curve:	0	<input checked="" type="radio"/>

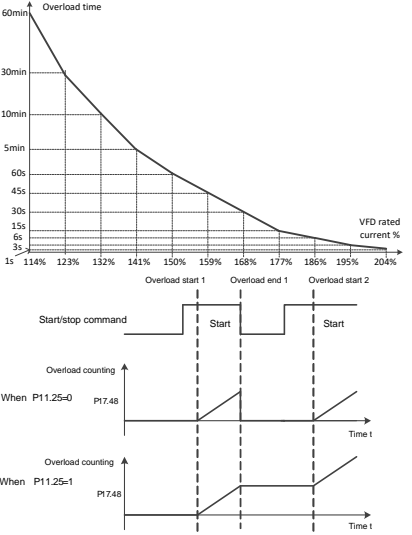
Function code	Name	Description	Default	Modify
				
P11.26	Enabling special functions	<p>0-1</p> <p>Ones place: indicates whether to enable special function 1</p> <p>0: Disable</p> <p>1: Enable</p> <p>Tens place: indicates whether to enable special function 2</p> <p>0: Disable</p> <p>1: Enable</p> <p>Special function 1 includes P11.03 (Overvoltage stall protection), P11.05 (Current-limit selection), P01.00 (Running mode of start), P00.13 (Running direction), P03.20 (Set upper limit of the torque when motoring via keypad), and P03.21 (Set upper limit of brake torque via keypad).</p> <p>When it is set to 0, special function codes are restored to the factory settings and are not displayed, and therefore cannot be modified.</p> <p>When it is set to 1, special function codes can be</p>	00	©

Function code	Name	Description	Default	Modify
		modified and used normally. Special function 2 includes: When it is set to 0, the function is invalid. When it is set to 1, different parameters are automatically matched for the open-loop vector and closed-loop vector.		
P11.27	VF oscillation control method	0x00–0x11 Ones place: 0: Method 1 1: Method 2 Tens place: Reserved Note: SMs support only method 1, while AMs support both methods.	0x00	☉
P11.28	SPO detection start delay time	0.0–60.0s Note: The SPO detection is started only after the VFD runs for the delay time specified by P11.28 to avoid false alarms caused by the unstable frequency.	5.0	○
P11.29	SPO unbalance factor	0–10	6	○
P11.30	Reserved	0–2	0	☉
P11.31	Fault severity group 1	0x0000–0x3333 Thousands place/Hundreds place/Tens place/Ones place: 0: Report the fault 1: Report the fault after deceleration to stop 2: Pre-alarm, with the action executed according to P11.51 3: Screen out the fault Note: Different fault actions are taken for different fault severities. The first 10 faults are not grouped by severity, but each four of the subsequent faults are grouped by severity in ascending order from right to left in hexadecimal format, that is, from the ones place to the thousands place (for example, the ones place of fault severity group 1 corresponds to fault 11,	0x0000	○
P11.32	Fault severity group 2		0x0000	○
P11.33	Fault severity group 3		0x0000	○
P11.34	Fault severity group 4		0x0000	○
P11.35	Fault severity group 5		0x0000	○
P11.36	Fault severity group 6		0x0000	○
P11.37	Fault severity group 7		0x0000	○
P11.38	Fault severity group 8		0x0000	○

Function code	Name	Description	Default	Modify
P11.39	Fault severity group 9	OL1). Group 1: Faults 11–14 (OL1, OL2, SPI, SPO)	0x0000	<input type="radio"/>
P11.40	Fault severity group 10	Group 2: Faults 15–18 (OH1, OH2, EF, CE) Group 3: Faults 19–22 (ItE, tE, EEP, PIDE)	0x0000	<input type="radio"/>
P11.41	Fault severity group 11	Group 4: Faults 23–26 (bCE, END, OL3, PCE) Group 5: Faults 27–30 (UPE, DNE, E-DP,	0x0000	<input type="radio"/>
P11.42	Fault severity group 12	E-NET) Group 6: Faults 31–34 (E-CAN, ETH1, ETH2,	0x0000	<input type="radio"/>
P11.43	Fault severity group 13	dEu) Group 7: Faults 35–38 (STo, LL, ENC1o,	0x0000	<input type="radio"/>
P11.44	Fault severity group 14	ENC1d) Group 8: Faults 39–42 (ENC1Z, STO, STL1,	0x0000	<input type="radio"/>
P11.45	Fault severity group 15	STL2) Group 9: Faults 43–46 (STL3, CrCE, P-E1,	0x0000	<input type="radio"/>
P11.46	Fault severity group 16	P-E2) Group 10: Faults 47–50 (P-E3, P-E4, P-E5,	0x0000	<input type="radio"/>
P11.47	Fault severity group 17	P-E6) Group 11: Faults 51–54 (P-E7, P-E8, P-E9,	0x0000	<input type="radio"/>
P11.48	Fault severity group 18	P-E10) Group 12: Faults 55–58 (E-Err, ENCU, E-PN,	0x0000	<input type="radio"/>
P11.49	Fault severity group 19	SECAN) Group 13: Faults 59–62 (OT, F1-Er, F2-Er,	0x0000	<input type="radio"/>
P11.50	Fault severity group 20	F3-Er) Group 14: Faults 63–66 (C1-Er, C2-Er, C3-Er,	0x0000	<input type="radio"/>
P11.51	Fault severity group 21	E-CAT) Group 15: Faults 67–70 (E-BAC, E-DEV, S-Err,	0x0000	<input type="radio"/>
P11.52	Fault severity group 22	dIS) Group 16: Faults 71–74 (tbE, FAE, tPF, STC) Group 17: Faults 75–78 (LSP, tCE, POE, SLE)	0x0000	<input type="radio"/>
P11.53	Fault severity group 23	Group 18: Faults 79–82 (bE, ELS, AdE, OtE1) Group 19: Faults 83–86 (OtE2, SFE, Cuu, PtcE)	0x0000	<input type="radio"/>
P11.54	Fault severity group 24	Group 20: Faults 87–90 (E-OvL, E-OS, E-dS,	0x0000	<input type="radio"/>
P11.55	Fault severity group 25	E-216) Group 21: Faults 91–94 (216EF, E-AI1, E-AI2, E-AI3) Group 22: Faults 95–98 (E-EIP, E-PAO, Reserved, Reserved) Group 23: Faults 99–102 (Reserved, Reserved,	0x0000	<input type="radio"/>

Function code	Name	Description	Default	Modify
		Reserved, Reserved) Group 24: Faults 103–106 (Reserved, Reserved, Reserved, Reserved) Group 25: Faults 107–110 (Reserved, Reserved, Reserved, Reserved)		
P11.56	Action for fault pre-alarm	0–4 0: Run at the set frequency 1: Run at the output frequency at the time of fault 2: Run at the frequency upper limit 3: Run at the frequency lower limit 4: Run at the frequency reserved for exception	0	<input type="radio"/>
P11.57	Frequency reserved for exception		0.00	<input type="radio"/>

P12 group—Parameters of motor 2

Function code	Name	Description	Default	Modify
P12.00	Type of motor 2	0: Asynchronous motor (AM) 1: Synchronous motor (SM)	0	<input checked="" type="radio"/>
P12.01	Rated power of AM 2	0.1–3000.0kW	Model depended	<input checked="" type="radio"/>
P12.02	Rated frequency of AM 2	0.01Hz– P00.03 (Max. output frequency)	50.00Hz	<input checked="" type="radio"/>
P12.03	Rated speed of AM 2	1–36000rpm	Model depended	<input checked="" type="radio"/>
P12.04	Rated voltage of AM 2	0–1200V	Model depended	<input checked="" type="radio"/>
P12.05	Rated current of AM 2	0.8–6000.0A	Model depended	<input checked="" type="radio"/>
P12.06	Stator resistance of AM 2	0.001–65.535Ω	Model depended	<input type="radio"/>
P12.07	Rotor resistance of AM 2	0.001–65.535Ω	Model depended	<input type="radio"/>
P12.08	Leakage	0.1–6553.5mH	Model	<input type="radio"/>

Function code	Name	Description	Default	Modify
	inductance of AM 2		depended	
P12.09	Mutual inductance of AM 2	0.1–6553.5mH	Model depended	○
P12.10	No-load current of AM 2	0.1–6553.5A	Model depended	○
P12.11	Magnetic saturation coefficient 1 of iron core of AM 2	0.0–100.0%	80%	○
P12.12	Magnetic saturation coefficient 2 of iron core of AM 2	0.0–100.0%	68%	○
P12.13	Magnetic saturation coefficient 3 of iron core of AM 2	0.0–100.0%	57%	○
P12.14	Magnetic saturation coefficient 4 of iron core of AM 2	0.0–100.0%	40%	○
P12.15	Rated power of SM 2	0.1–3000.0kW	Model depended	⊙
P12.16	Rated frequency of SM 2	0.01Hz– P00.03 (Max. output frequency)	50.00Hz	⊙
P12.17	Number of pole pairs of SM 2	1–128	2	⊙
P12.18	Rated voltage of SM 2	0–1200V	Model depended	⊙
P12.19	Rated current of SM 2	0.8–6000.0A	Model depended	⊙
P12.20	Stator resistance of SM 2	0.001–65.535Ω	Model depended	○
P12.21	Direct-axis inductance of SM 2	0.01–655.35mH	Model depended	○

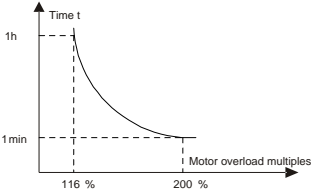
Function code	Name	Description	Default	Modify
P12.22	Quadrature-axis inductance of SM 2	0.01–655.35mH	Model depended	<input type="radio"/>
P12.23	Counter-emf constant of SM 2	0–10000V	300	<input type="radio"/>
P12.24	Reserved	0–0xFFFF	0x0000	<input checked="" type="radio"/>
P12.25	Reserved	0%–50.0% (of the motor rated current)	10%	<input checked="" type="radio"/>
P12.26	Overload protection of motor 2	0: No protection 1: Common motor (with low-speed compensation) 2: Frequency-variable motor (without low-speed compensation)	2	<input checked="" type="radio"/>
P12.27	Overload protection coefficient of motor 2	<p>Motor overload multiples $M = I_{out} / (I_n * K)$ "In" is rated motor current, "Iout" is VFD output current, and "K" is motor overload protection coefficient. A smaller value of "K" indicates a bigger value of "M". When $M = 116\%$, protection is performed after motor overload lasts for 1 hour; when $M = 200\%$, protection is performed after motor overload lasts for 60 seconds; and when $M \geq 400\%$, protection is performed immediately.</p>  <p>Setting range: 20.0% –120.0%</p>	100.0%	<input type="radio"/>
P12.28	Power display calibration coefficient of motor 2	0.00–3.00	1.00	<input type="radio"/>
P12.29	Parameter display of motor 2	0: Display by motor type. In this mode, only parameters related to the present motor type are displayed.	0	<input type="radio"/>

Function code	Name	Description	Default	Modify
		1: Display all. In this mode, all the motor parameters are displayed.		
P12.30	System inertia of motor 2	0–30.000kgm ²	0.000	<input type="radio"/>
P12.31	Speed control switchover mode of motor 2	0: No switchover, which indicates keeping consistant with P00.00 of motor 1 1: Switch to SVC1 2: Switch to VF mode 3: Switch to FVC	0	<input checked="" type="radio"/>

P13 group—SM control

Function code	Name	Description	Default	Modify
P13.00	SM injected-current decrease ratio	Used to set the reduction rate of the input reactive current. When the active current of the synchronous motor increases to some extent, the input reactive current can be reduced to improve the power factor of the motor. Setting range: 0.0%–100.0% (of the motor rated current)	80.0%	<input type="radio"/>
P13.01	Detection mode of initial pole	0: No detection 1: High-frequency superposition 2: Pulse superposition	0	<input checked="" type="radio"/>
P13.02	Pull-in current 1	Pull-in current is the pole position orientation current; pull-in current 1 is valid within the lower limit of pull-in current switch-over frequency threshold. If you need to increase the start torque, increase the value of this function parameter properly. Setting range: 0.0%–100.0% (of the motor rated current)	20.0%	<input type="radio"/>
P13.03	Pull-in current 2	Pull-in current is the pole position orientation current; pull-in current 2 is valid within the lower limit of pull-in current switch-over frequency threshold. You do not need to change the value in most cases. Setting range: 0.0%–100.0% (of the motor rated current)	10.0%	<input type="radio"/>

Function code	Name	Description	Default	Modify
P13.04	Source-current switchover frequency	0.00Hz– P00.03 (Max. output frequency)	10.00Hz	<input type="radio"/>
P13.05	High-frequency superposition frequency	200Hz–1000Hz	500Hz	<input checked="" type="radio"/>
P13.06	High-frequency superposition voltage	Used to set the pulse current threshold when the initial magnetic pole position is detected in the pulse mode, The value is a percentage in relative to the rated current of the motor. Setting range: 0.0–300.0% (of the motor rated voltage)	100.0%	<input checked="" type="radio"/>
P13.07	Control parameter 0	0.0–400.0	0.0	<input type="radio"/>
P13.08	Control parameter 1	0–0xFFFF	0	<input type="radio"/>
P13.09	Phase-locked loop switch-on frequency point	Used to set the frequency threshold for enabling the counter-electromotive force phase-locked loop in SVC 0. When the running frequency is lower than the value of the function code, the phase-locked loop is disabled; and when the running frequency is higher than that, the phase-locked loop is enabled. Setting range: 0–655.35	50.00	<input type="radio"/>
P13.10	Initial compensation angle of SM	0.0–359.9	0.0	<input type="radio"/>
P13.11	Maladjustment detection time	Used to adjust the responsiveness of anti-maladjustment function. If the load inertia is large, increase the value of this parameter properly, however, the responsiveness may slow down accordingly. Setting range: 0.0–10.0s	0.5s	<input type="radio"/>
P13.12	High-frequency compensation coefficient of SM	Valid when the motor speed exceeds the rated speed. If oscillation occurred to the motor, adjust this parameter properly. Setting range: 0.0–100.0%	0.0%	<input type="radio"/>

Function code	Name	Description	Default	Modify
P13.13	High-frequency current-loop	0–300.0% (of the rated VFD output current)	20.0%	☉

P14 group—Serial communication

Function code	Name	Description	Default	Modify
P14.00	Local communication address	Setting range: 1–247 When the master writes the slave communication address to 0 indicating a broadcast address in a frame, all the slaves on the Modbus bus receive the frame but do not respond to it. The communication addresses on the communication network are unique, which is the basis of the point-to-point communication. Note: The communication address of a slave cannot be set to 0.	1	○
P14.01	Communication baud rate	The function code is used to set the rate of data transmission between the upper computer and the VFD. 0: 1200BPS 1: 2400BPS 2: 4800BPS 3: 9600BPS 4: 19200BPS 5: 38400BPS 6: 57600BPS 7: 115200BPS Note: The baud rate set on the VFD must be consistent with that on the upper computer. Otherwise, the communication fails. A greater baud rate indicates faster communication.	4	○
P14.02	Data bit check	The data format set on the VFD must be consistent with that on the upper computer. Otherwise, the communication fails. 0: No check (N, 8, 1) for RTU 1: Even check (E, 8, 1) for RTU	1	○

Function code	Name	Description	Default	Modify
		2: Odd check (O, 8, 1) for RTU 3: No check (N, 8, 2) for RTU 4: Even check (E, 8, 2) for RTU 5: Odd check (O, 8, 2) for RTU		
P14.03	Communication response delay	0–200ms The function code indicates the communication response delay, that is, the interval from when the VFD completes receiving data to when it sends response data to the upper computer. If the response delay is shorter than the rectifier processing time, the rectifier sends response data to the upper computer after processing data. If the delay is longer than the rectifier processing time, the rectifier does not send response data to the upper computer until the delay is reached although data has been processed.	5	<input type="radio"/>
P14.04	Communication timeout time	0.0 (invalid)–60.0s When the function code is set to 0.0, the communication timeout time is invalid. When the function code is set to a non-zero value, the system reports the "485 communication fault" (CE) if the communication interval exceeds the value. In general, the function code is set to 0.0. When continuous communication is required, you can set the function code to monitor communication status.	0.0s	<input type="radio"/>
P14.05	Transmission error processing	0: Report an alarm and coast to stop 1: Keep running without reporting an alarm 2: Stop according to the stop mode without generating alarms (only in the communication-based control mode) 3: Stop according to the stop mode without generating alarms (in all control modes)	0	<input type="radio"/>
P14.06	Modbus communication	0x000–0x111 Ones place:	0x00	<input type="radio"/>

Function code	Name	Description	Default	Modify
	processing action	0: Respond to write operations 1: Not respond to write operations Tens place: 0: Password protection is invalid. 1: Password protection is valid. Hundreds place: 0: User-defined addresses of P14.07 and P14.08 are invalid. 1: User-defined addresses of P14.07 and P14.08 are valid.		
P14.07	User-defined running command address	0x0000–0xFFFF Note: It indicates the user-defined Modbus run command address.	0x2000	<input type="radio"/>
P14.08	User-defined frequency setting address	0x0000–0xFFFF Note: It indicates the user-defined Modbus frequency setting address.	0x2001	<input type="radio"/>
P14.09	Modbus TCP communication timeout time	0.0–60.0(s) Note: 0.0 indicates the function is invalid.	5.0	<input type="radio"/>
P14.10	Enabling program upgrade through RS485	0–1 0: Disable 1: Enable	0	<input checked="" type="radio"/>
P14.11	Bootloader software version	0.00–655.35	0.00	<input checked="" type="radio"/>
P14.12	Displaying no upgrade bootloader fault	0–1 0: Display 1: Do not display	1	<input type="radio"/>
P14.48	Channel selection for mapping between PZDs and function codes	0x00–0x12 Ones place: Channel for mapping function codes to PZDs 0: Reserved 1: Group P15 2: Group P16 Tens place: Save function at power failure 0: Disable 1: Enable	0x12	<input type="radio"/>

Function code	Name	Description	Default	Modify
P14.49	Mapped function code of received PZD2	0x0000-0xFFFF	0x0000	<input type="radio"/>
P14.50	Mapped function code of received PZD3	0x0000-0xFFFF	0x0000	<input type="radio"/>
P14.51	Mapped function code of received PZD4	0x0000-0xFFFF	0x0000	<input type="radio"/>
P14.52	Mapped function code of received PZD5	0x0000-0xFFFF	0x0000	<input type="radio"/>
P14.53	Mapped function code of received PZD6	0x0000-0xFFFF	0x0000	<input type="radio"/>
P14.54	Mapped function code of received PZD7	0x0000-0xFFFF	0x0000	<input type="radio"/>
P14.55	Mapped function code of received PZD8	0x0000-0xFFFF	0x0000	<input type="radio"/>
P14.56	Mapped function code of received PZD9	0x0000-0xFFFF	0x0000	<input type="radio"/>
P14.57	Mapped function code of received PZD10	0x0000-0xFFFF	0x0000	<input type="radio"/>
P14.58	Mapped function code of received PZD11	0x0000-0xFFFF	0x0000	<input type="radio"/>
P14.59	Mapped function code of received PZD12	0x0000-0xFFFF	0x0000	<input type="radio"/>
P14.60	Mapped function code of sent PZD2	0x0000-0xFFFF	0x0000	<input type="radio"/>
P14.61	Mapped function	0x0000-0xFFFF	0x0000	<input type="radio"/>

Function code	Name	Description	Default	Modify
	code of sent PZD3			
P14.62	Mapped function code of sent PZD4	0x0000–0xFFFF	0x0000	○
P14.63	Mapped function code of sent PZD5	0x0000–0xFFFF	0x0000	○
P14.64	Mapped function code of sent PZD6	0x0000–0xFFFF	0x0000	○
P14.65	Mapped function code of sent PZD7	0x0000–0xFFFF	0x0000	○
P14.66	Mapped function code of sent PZD8	0x0000–0xFFFF	0x0000	○
P14.67	Mapped function code of sent PZD9	0x0000–0xFFFF	0x0000	○
P14.68	Mapped function code of sent PZD10	0x0000–0xFFFF	0x0000	○
P14.69	Mapped function code of sent PZD11	0x0000–0xFFFF	0x0000	○
P14.70	Mapped function code of sent PZD12	0x0000–0xFFFF	0x0000	○

P15 group—Communication expansion card 1 functions

Function code	Name	Description	Default	Modify
P15.00–P15.27	See the operation manual of communication expansion card for details			
P15.28	Master/slave CAN communication address	0–127	1	◎

Function code	Name	Description	Default	Modify
P15.29	Master/slave CAN communication baud rate	0: 50Kbps 1: 100Kbps 2: 125Kbps 3: 250Kbps 4: 500Kbps 5: 1M bps	2	☉
P15.30	Master/slave CAN communication timeout period	0.0 (invalid)–60.0s	0.0s	○
P15.31– P15.69	See Goodrive350 series VFD communication expansion card manual for details.			

P16 group—Communication expansion card 2 functions

Function code	Name	Description	Default	Modify
P16.00– P16.23	See Goodrive350 series VFD communication expansion card manual for details.			
P16.24	Time to identify expansion card in card slot 1	0.0–600.0s The value 0.0 indicates that identification fault will not be detected.	0.0s	○
P16.25	Time to identify expansion card in card slot 2	0.0–600.0s The value 0.0 indicates that identification fault will not be detected.	0.0s	○
P16.26	Time to identify expansion card in card slot 3	0.0–600.0s The value 0.0 indicates that identification fault will not be detected.	0.0s	○
P16.27	Communication timeout period of card at slot 1	0.0–600.0s The value 0.0 indicates offline fault will not be detected.	0.0s	○
P16.28	Communication timeout period of card at slot 2	0.0–600.0s The value 0.0 indicates offline fault will not be detected.	0.0s	○
P16.29	Communication timeout period of card at slot 3	0.0–600.0s The value 0.0 indicates offline fault will not be detected.	0.0s	○
P16.30– P16.53	See Goodrive350 series VFD communication expansion card manual for details.			
P16.54	EtherNet IP	0.0–60.0s	5.0	○

Function code	Name	Description	Default	Modify
	communication timeout time	For an EtherNet IP communication fault, the VFD reports "E-EIP". The value 0.0 indicates invalid.		
P16.55	EtherNet IP communication rate	0: Self-adaptive 1: 100M full-duplex 2: 100M half-duplex 3: 10M full-duplex 4: 10M half-duplex	0	☉
P16.56	Bluetooth pairing code	0 - 65535	0	●
P16.57	Bluetooth host type	0-65535 0: No host connection 1: Mobile APP 2: Bluetooth box 3-65535: Reserved	0	●
P16.58	EtherNet IP communication card IP address 1	0-255	192	☉
P16.59	EtherNet IP communication card IP address 2	0-255	168	☉
P16.60	EtherNet IP communication card IP address 3	0-255	0	☉
P16.61	EtherNet IP communication card IP address 4	0-255	20	☉
P16.62	EtherNet IP communication card subnet mask 1	0-255	255	☉
P16.63	EtherNet IP communication card subnet	0-255	255	☉

Function code	Name	Description	Default	Modify
	mask2			
P16.64	EtherNet IP communication card subnet mask3	0-255	255	⊙
P16.65	EtherNet IP communication card subnet mask4	0-255	0	⊙
P16.66	EtherNet IP communication card gateway1	0-255	192	⊙
P16.67	EtherNet IP communication card gateway2	0-255	168	⊙
P16.68	EtherNet IP communication card gateway3	0-255	0	⊙
P16.69	EtherNet IP communication card gateway4	0-255	1	⊙
P16.70	Two-in-one card working mode	0: CAN master/slave Ethernet two-in-one card 1: CAN master/slave card 2: Ethernet card If the parameter setting is changed, the change takes effect only after the VFD is restarted.	0	⊙
P16.71	CAN data frame sending/receiving delay	When the two-in-one card working mode is 0, the CAN data frame sending/receiving cycle, the time is 0.25ms. A greater parameter setting indicates longer CAN master/slave communication delay, but shorter Ethernet oscilloscope data indicates better oscilloscope effect. Adjust the parameter setting based on the number of slaves to obtain good oscilloscope effect when the master/slave communication is normal.	5	⊙

Function code	Name	Description	Default	Modify
		If the parameter setting is changed, the change takes effect only after the VFD is restarted. Range: 0–20		
P16.72	CW and SW selection	0: Standard CWs and SWs 1: CWs and SWs for port crane applications 2: CWs and SWs for special CANopen	0	☉
P16.73	Communication set ACC/DEC time selection	0: Non communication 1: PROFIBUSDP or CANopen communication 2: PROFIBUSNet or EtherNet IP communication	0	☉

P17 group—Status viewing

Function code	Name	Description	Default	Modify
P17.00	Set frequency	Displays the present set frequency of the VFD. Range: 0.00Hz– P00.03	50.00Hz	●
P17.01	Output frequency	Displays the present output frequency of the VFD. Range: 0.00Hz– P00.03	0.00Hz	●
P17.02	Ramp reference frequency	Displays the present ramp reference frequency of the VFD. Range: 0.00Hz– P00.03	0.00Hz	●
P17.03	Output voltage	Displays the present output voltage of the VFD. Range: 0–1200V	0V	●
P17.04	Output current	Displays the valid value of current output current of the VFD. Range: 0.0–5000.0A	0.0A	●
P17.05	Motor rotation speed	Displays the current motor speed. Range: 0–65535RPM	0 RPM	●
P17.06	Torque current	Displays the present torque current of the VFD. Range: -3000.0–3000.0A	0.0A	●
P17.07	Exciting current	Displays the present exciting current of the VFD. Range: -3000.0–3000.0A	0.0A	●
P17.08	Motor power	Displays the present motor power; 100% relative to the rated motor power. The positive value is the motoring state while the negative value is the generating state. Range: -300.0–300.0% (relative to the rated motor power)	0.0%	●

Function code	Name	Description	Default	Modify
P17.09	Motor output torque	Displays the present output torque of the VFD; 100% relative to the rated motor torque. During forward running, the positive value is the motoring state while the negative value is generating state. During reverse running, the positive value is the generating state while the negative value is the motoring state. Range: -250.0–250.0%	0.0%	●
P17.10	Estimated motor frequency	Displays the estimated motor rotor frequency under the open-loop vector condition. Range: 0.00– P00.03	0.00Hz	●
P17.11	DC bus voltage	Displays the present DC bus voltage of the VFD. Range: 0.0–2000.0 V	0V	●
P17.12	Digital input terminal status	Displays the present digital input terminal state of the VFD. 0x00–0x3F Corresponds to HDIB, HDIA, S4, S3, S2 and S1 respectively.	0	●
P17.13	Digital output terminal status	Displays the present digital output terminal state of the VFD. 0x0–0xF Corresponds to RO2, RO1, HDO and Y1 respectively	0	●
P17.14	Digital adjustment value	Displays the adjustment on the VFD through the UP/DOWN terminal. Range: 0.00Hz– P00.03	0.00Hz	●
P17.15	Torque reference value	Relative to the percentage of the rated torque of the present motor, displaying the torque reference. Range: -300.0%–300.0% (of the motor rated current)	0.0%	●
P17.16	Linear speed	0–65535	0	●
P17.17	Reserved	0–65535	0	●
P17.18	Count value	0–65535	0	●
P17.19	AI1 input voltage	Displays the AI1 input signal. Range: 0.00–10.00V	0.00V	●
P17.20	AI2 input voltage	Displays the AI2 input signal. Range: -10.00V–10.00V	0.00V	●

Function code	Name	Description	Default	Modify
P17.21	HDIA input frequency	Display HDIA input frequency. Range: 0.000–50.000kHz	0.000 kHz	●
P17.22	HDIB input frequency	Display HDIB input frequency. Range: 0.000–50.000kHz	0.000 kHz	●
P17.23	PID reference value	Displays the PID reference value. Range: -100.0–100.0%	0.0%	●
P17.24	PID feedback value	Displays the PID feedback value. Range: -100.0–100.0%	0.0%	●
P17.25	Motor power factor	Displays the power factor of the current motor. Range: -1.00–1.00	1.00	●
P17.26	Duration of this run	Displays the duration of this run of the VFD. Range: 0–65535min	0m	●
P17.27	Simple PLC and actual step of multi-step speed	Displays simple PLC and present step number of multi-step speed. Range: 0–15	0	●
P17.28	Motor ASR controller output	Displays the ASR controller output value under the vector control mode, relative to the percentage of rated motor torque. Range: -300.0%–300.0% (of the motor rated current)	0.0%	●
P17.29	Pole angle of open-loop SM	Displays the initial identification angle of SM. Range: 0.0–360.0	0.0	●
P17.30	Phase compensation of SM	Displays the phase compensation of SM. Range: -180.0–180.0	0.0	●
P17.31	High-frequency superposition current of SM	0.0%–200.0% (of the motor rated current)	0.0	●
P17.32	Motor flux linkage	0.0%–200.0%	0.0%	●
P17.33	Exciting current reference	Displays the exciting current reference value under the vector control mode. Range: -3000.0–3000.0A	0.0A	●
P17.34	Torque current reference	Displays the torque current reference value under the vector control mode. Range: -3000.0–3000.0A	0.0A	●
P17.35	AC incoming current	Displays the valid value of incoming current on AC side.	0.0A	●

Function code	Name	Description	Default	Modify
		Range: 0.0–5000.0A		
P17.36	Output torque	Displays the output torque value. During forward running, the positive value is the motoring state while the negative value is generating state. During reverse running, the positive value is the generating state while the negative value is the motoring state. Range: -3000.0Nm–3000.0Nm	0.0Nm	●
P17.37	Motor overload count value	0–65535	0	●
P17.38	Process PID output	-100.0%–100.0%	0.00%	●
P17.39	Function codes in parameter download error	0.00–99.00	0.00	●
P17.40	Motor control mode	Ones place: Control mode 0: Vector 0 1: Vector 1 2: Space voltage vector control 3: Closed-loop vector control Tens place: Control status 0: Speed control 1: Torque control 2: Position control 0: Motor 1 1: Motor 2 2: Motor 3	0x2	●
P17.41	Electromotive torque upper limit	0.0%–300.0% (of the motor rated current)	180.0%	●
P17.42	Braking torque upper limit	0.0%–300.0% (of the motor rated current)	180.0%	●
P17.43	Forward rotation upper-limit frequency in torque control	0.00– P00.03	50.00Hz	●
P17.44	Reverse rotation upper-limit frequency in	0.00– P00.03	50.00Hz	●

Function code	Name	Description	Default	Modify
	torque control			
P17.45	Inertia compensation torque	-100.0%~100.0%	0.0%	●
P17.46	Friction compensation torque	-100.0%~100.0%	0.0%	●
P17.47	Motor pole pairs	0~65535	0	●
P17.48	VFD overload count value	0~65535	0	●
P17.49	Frequency set by A source	0.00~ P00.03	0.00Hz	●
P17.50	Frequency set by B source	0.00~ P00.03	0.00Hz	●
P17.51	PID proportional output	-100.0%~100.0%	0.00%	●
P17.52	PID integral output	-100.0%~100.0%	0.00%	●
P17.53	PID differential output	-100.0%~100.0%	0.00%	●
P17.54	Present proportional gain	0.00~100.00	0.00%	●
P17.55	Present integral time	0.00~10.00s	0.00%	●
P17.56	Present differential time	0.00~10.00s	0.00%	●
P17.57	Present terminal status in multi-step speed setting	0~0xf	0	●
P17.58	High bits in VFD power generated	0~65535 kWh (*1000)	0	●
P17.59	Low bits in VFD power generated	0.0~999.9 kWh	0.0	●

P18 group—Status viewing in closed-loop control

Function code	Name	Description	Default	Modify
P18.00	Actual frequency of encoder	Used to indicate the actual-measured encoder frequency. The value of forward running is positive; the value of reverse running is negative. Range: -999.9–3276.7Hz	0.0Hz	●
P18.01	Encoder position count value	Encoder count value, quadruple frequency. Range: 0–65535	0	●
P18.02	Encoder Z pulse count value	Corresponding count value of encoder Z pulse. Range: 0–65535	0	●
P18.03	High-order bit of position reference value	It is cleared after stop. Setting range: 0–30000	0	●
P18.04	Low-order bit of position reference value	It is cleared after stop. Range: 0–65535	0	●
P18.05	High-order bit of position feedback value	It is cleared after stop. Setting range: 0–30000	0	●
P18.06	Low-order bit of position feedback value	It is cleared after stop. Range: 0–65535	0	●
P18.07	Position deviation	Deviation between the reference position and actual running position. Setting range: -32768–32767	0	●
P18.08	Position of position reference point	Position of reference point of Z pulse when the spindle stops accurately. Range: 0–65535	0	●
P18.09	Present position setting of spindle	Present position setup when the spindle stops accurately. Setting range: 0–359.99	0.00	●
P18.10	Present position when spindle stops accurately	Present position when the spindle stops accurately. Range: 0–65535	0	●
P18.11	Encoder Z pulse direction	Z pulse direction display. When the spindle stops accurately, there may be a couple of pulses' error between the position of forward and reverse orientation, which can be eliminated	0	●

Function code	Name	Description	Default	Modify
		by adjusting Z pulse direction of P20.02 or exchanging phase AB of encoder. 0: Forward 1: Reverse		
P18.12	Encoder Z pulse angle	Reserved. Setting range: 0.00–359.99	0.00	●
P18.13	Encoder Z pulse error times	Reserved. Range: 0–65535	0	●
P18.14	High-order bits of encoder pulse count value	Encoder pulse count value. The count value is accumulated only if the VFD is powered on. 0–65535	0	●
P18.15	Low-order bits of encoder pulse count value	Encoder pulse count value. The count value is accumulated only if the VFD is powered on. 0–65535	0	●
P18.16	Speed measured by main control board	-3276.8–3276.7Hz	0.0Hz	●
P18.17	Pulse command frequency	Pulse command (A2/B2 terminal) is converted to the set frequency, and it is valid under the pulse position mode and pulse speed mode. Range: -3276.8–3276.7Hz	0.00Hz	●
P18.18	Pulse command feedforward	Pulse command (A2/B2 terminal) is converted to the set frequency, and it is valid under the pulse position mode and pulse speed mode. Range: -3276.8–3276.7Hz	0.00Hz	●
P18.19	Position regulator output	Position regulator output frequency in position control. Range: -3276.8–3276.7Hz	0	●
P18.20	Count value of resolver	Count value of the resolver. Range: 0–65535	0	●
P18.21	Resolver angle	Pole position angle read by the resolver-type encoder. Setting range: 0.00–359.99	0.00	●
P18.22	Pole angle of closed-loop SM	Present pole position. Setting range: 0.00–359.99	0.00	●
P18.23	SW 2	0–65535	0	●
P18.24	High-order bit of count value of pulse reference	Pulse command (A2,B2) count value. The count value is accumulated only if the VFD is powered on.	0	●

Function code	Name	Description	Default	Modify
		0–65535		
P18.25	Low-order bit of count value of pulse reference	Pulse command (A2,B2) count value. The count value is accumulated only if the VFD is powered on. 0–65535	0	●
P18.26	Speed measured by PG card	-3276.8–3276.7Hz	0.0Hz	●
P18.27	Encoder UVW sectors	0–7	0	●
P18.28	Encoder PPR display	0–65535	0	●
P18.29	Angle compensation value of SM	-180.0–180.0	0.0	●
P18.30	Z pulse angle of SM	0.00–655.35	0	●
P18.31	Z pulse value of pulse reference	0–65535	0	●
P18.32	Main control board measured value of pulse reference	-3276.8–3276.7Hz	0.0Hz	●
P18.33	PG card measured value of pulse reference	-3276.8–3276.7Hz	0.0Hz	●
P18.34	Present encoder filter width	0–63	0	●
P18.35	Reserved	0–65535	0	●

P19 group—Expansion card status viewing

Function code	Name	Description	Default	Modify
P19.00	Expansion card type of card slot 1	0–65535 0: No card	0	●
P19.01	Expansion card type of card slot 2	1: PLC card 2: I/O card 1	0	●
P19.02	Expansion card type of card slot 3	3: Incremental PG card 4: Incremental PG card with UVW 5: Ethernet	0	●

Function code	Name	Description	Default	Modify
		6: DP 7: Bluetooth card 8: Rotary PG card 9: CANopen communication card 10: WIFI card 11: PROFINET communication card 12: Sine-cosine PG card without CD signals 13: Sine-cosine PG card with CD signals 14: Absolute encoder PG card 15: CAN master/slave communication card 16: Modbus/Modbus TCP communication card 17: EtherCAT 18: BACnet 19: DeviceNet communication card 20: I/O card 2 for hoisting 21: EtherNet IP communication card 22: MECHATROLINK card 23: Reserved 24: CAN-NET two-in-one communication card 25: 216 communication card		
P19.03	Software version of card at slot 1	0.00–655.35	0.00	●
P19.04	Software version of card at slot 2	0.00–655.35	0.00	●
P19.05	Software version of card at slot 3	0.00–655.35	0.00	●
P19.06	Terminal input status of I/O card	0–0xFFFF	0	●
P19.07	Terminal output status of I/O card	0–0xFFFF	0	●
P19.09	AI3 input voltage of I/O card	0.00–10.00V	0.00V	●
P19.15	VFD control word	0x0000–0xFFFF It indicates the control word that the upper computer sends to the VFD through PROFIBUS-DP/CANopen/PROFINET/216 card communication.	0x000	●

Function code	Name	Description	Default	Modify
P19.16	VFD status word	0x0000–0xFFFF It indicates the status word that the VFD returns to the upper computer through PROFIBUS-DP/CANopen/PROFINET/216 card communication.	0x000	●
P19.17	Ethernet monitoring variable 1	0–65535	0	●
P19.18	Ethernet monitoring variable 2	0–65535	0	●
P19.19	Ethernet monitoring variable 3	0–65535	0	●
P19.20	Ethernet monitoring variable 4	0–65535	0	●

P20 group—Encoder of motor 1

Function code	Name	Description	Default	Modify
P20.00	Encoder type display	0: Incremental encoder 1: Resolver-type encoder 2: Sin/Cos encoder 3: Endat absolute encoder	0	●
P20.01	Encoder pulse number	Number of pulses generated when the encoder revolves for one circle. Setting range: 0–16000	1024	◎
P20.02	Encoder direction	Ones place: AB direction 0: Forward 1: Reverse Tens place: Z pulse direction (reserved) 0: Forward 1: Reverse Hundreds: CD/UVW pole signal direction 0: Forward 1: Reverse	0x000	◎
P20.03	Detection time of	Detection time of encoder offline fault (ENC1o).	2.0s	○

Function code	Name	Description	Default	Modify
	encoder offline fault	Setting range: 0.0–10.0s		
P20.04	Detection time of encoder reversal fault	Detection time of encoder reversal fault (ENC1d). Setting range: 0.0–100.0s	0.8s	○
P20.05	Filter times of encoder detection	Setting range: 0x00 –0x99 Ones place: Low-speed filter time, corresponding to $2^{(0-9)} * 125\mu s$. Tens place: High-speed filter times, corresponding to $2^{(0-9)} * 125\mu s$.	0x33	○
P20.06	Speed ratio between encoder mounting shaft and motor	You need to set the function parameter when the encoder is not installed on the motor shaft and the drive ratio is not 1. Setting range: 0.001–65.535	1.000	○
P20.07	Control parameters of SM	Bit0: Enable Z pulse calibration Bit1: Enable encoder angle calibration Bit2: Enable SVC speed measurement Bit3: Reserved Bit4: Reserved Bit5: Reserved Bit6: Enable the CD signal calibration Bit7: Reserved Bit8: Do not detect encoder faults during autotuning Bit9: Enable Z pulse detection optimization Bit10: Enable the initial Z pulse calibration optimization Bit12: Clear the Z pulse arrival signal after stop Bit14: Detect the Z pulse after one turn of rotation	0x0003	○
P20.08	Enable Z pulse offline detection	0x00–0x11 Ones place: Z pulse detection 0: Disable 1: Enable Tens place: UVW pulse detection (for SM) 0: Disable 1: Enable	0x10	○
P20.09	Initial angle of Z	Relative electric angle between the encoder Z	0.00	○

Function code	Name	Description	Default	Modify
	pulse	pulse and the motor pole position. Setting range: 0.00–359.99		
P20.10	Pole initial angle	Relative electric angle between the encoder position and the motor pole position. Setting range: 0.00–359.99	0.00	○
P20.11	Autotuning pole initial angle	Range: 0–3 1: Rotary autotuning (DC braking) 2: Static autotuning (suitable for resolver-type encoder, sin/cos with CD signal feedback) 3: Rotary autotuning (initial angle identification) The pole initial angle obtained through rotary autotuning 1 is accurate. Rotary autotuning is recommended in most cases, in which the motor needs to be decoupled from the load or the motor load is light.	0	◎
P20.12	Speed measurement optimization selection	0: No optimization 1: Optimization mode 1 2: Optimization mode 2	1	◎
P20.13	CD signal zero offset gain	0–65535	0	○
P20.14	Encoder type selection	Ones place: Incremental encoder 0: without UVW 1: with UVW Tens place: Sin/Cos encoder 0: without CD signal 1: with CD signal	0x00	◎
P20.15	Speed measurement mode	0: Measuring speed by PG card/Measuring height by HDI 1: Measuring locally through HDIA and HDIB. Only the 24V incremental encoders are supported. 2: Pulses are obtained through CANopen or PROFIBUS-DP communication to measure the speed. 3: Pulses are obtained through PROFINET or EtherNet IP communication to measure the speed.	0	◎

Function code	Name	Description	Default	Modify
		Note: HDI height measuring is implemented through the HDIA and HDIB and supports only incremental 24V encoders.		
P20.16	Frequency division coefficient	0–255 When the function parameter is set to 0 or 1, frequency division of 1:1 is implemented.	0	○
P20.17	Pulse filter handling selection	0x0000–0xFFFF Bit0: Enable/disable encoder input filter 0: No filter 1: Filter Bit1: Encoder signal filter mode 0: Self-adaptive filter 1: Use P20.18 filter parameter Bit2: Enable/disable encoder frequency-division output filter 0: No filter 1: Filter Bit3: Enable/disable pulse reference frequency-division output filter 0: No filter 1: Filter Bit4: Enable/disable pulse reference filter 0: No filter 1: Filter Bit5: Pulse reference filter mode (valid when Bit4 is set to 1) 0: Self-adaptive filter 1: Use P20.19 filter parameter Bit6: Frequency-divided output source setting 0: Encoder signals 1: Pulse reference signals Bit7–15: Reserved	0x0033	○
P20.18	Encoder pulse filter width	0–63 The filter time is P20.18 *0.25μs. The value 0 or 1 indicates 0.25μs.	2	○
P20.19	Pulse reference filter width	0–63 The filter time is P20.19 *0.25μs. The value 0 or 1 indicates 0.25μs.	2	○

Function code	Name	Description	Default	Modify
P20.20	Pulse number of pulse reference	0–65535	1024	☉
P20.21	Enabling SM angle compensation	0–1	0	○
P20.22	Frequency point of speed measurement mode switchover	0–630.00Hz Note: Valid only when P20.12 =0.	1.00Hz	○
P20.23	Angle compensation coefficient	-200.0–200.0	100.0%	○
P20.24	Motor pole pairs in initial pole angle autotuning	1–128	2	☉

P21 group—Position control

Function code	Name	Description	Default	Modify
P21.00	Positioning mode	Ones place: Control mode selection (only for closed-loop vector control) 0: Speed control 1: Position control Tens place: Position command source 0: Pulse string, using PG card terminal (A2, B2) pulse giving signal for position control 1: Digital position, using the setting of P21.17 for position control, while the positioning mode can be set through P21.16 . 2: Positioning of photoelectric switch during stop. When a terminal receives a photoelectric switch signal (selection terminal function 43), the VFD starts positioning for stop, and the stop distance can be set through P21.17 . Hundred place: Position feedback source 0: Encoder signals 1: Reserved Thousands place: Servo mode (Reserved)	0x0000	○

Function code	Name	Description	Default	Modify
		Bit0: Position deviation mode 0: No deviation 1: With deviation Bit1: Enable/disable servo 0: Disable (The servo can be enabled by terminals.) 1: Enable Bit2–Bit7: Reserved Note: In the pulse string or spindle positioning mode, the VFD enters the servo operation mode when there is a valid servo enabling signal. If there is no servo enabling signal, the VFD enter the servo operation mode only after it receives a forward running or reverse running command.		
P21.01	Pulse command mode	Ones place: Pulse mode 0: A/B quadrature pulse; A leads B 1: A is PULSE and B is SIGN If channel B is of low electric level, the edge counts up; if channel B is of high electric level, the edge counts down. 2: A is positive pulse Channel A is positive pulse; channel B needs no wiring 3: A/B dual-channel pulse; channel A pulse edge counts up, channel B pulse edge counts down Tens place: Pulse direction Bit0: Set pulse direction 0: Forward 1: Reverse Bit1: Set pulse direction by running direction 0: Disable, and BIT0 is valid 1: Enable Hundreds place: Frequency multiplication selection for pulse +direction (reserved) 0: No frequency multiplication 1: Frequency multiplication	0x0000	©

Function code	Name	Description	Default	Modify
		Thousands place: Pulse control selection Bit0: Pulse filter selection 0: Inertia filter 1: Moving average filter Bit1: Overspeed control 0: No control 1: Control		
P21.02	APR gain 1	The two automatic position regulator (APR)	20.0	<input type="radio"/>
P21.03	APR gain 2	gains are switched based on the switching mode set through P21.04 . When the spindle orientation function is used, the gains are switched automatically, regardless of the setting of P21.04 . P21.03 is used for dynamic running, and P21.02 is used for maintaining the locked state. Setting range: 0.0–400.0	30.0	<input type="radio"/>
P21.04	APR gain switchover mode	Used to select the mode for switching between APR gains. To use torque command-based switching, you need to set P21.05 ; and to use speed command-based switching, you need to set P21.06 . 0: No switchover 1: Torque command 2: Speed command 3–5: Reserved	0	<input type="radio"/>
P21.05	APR gain switchover threshold in torque command	Setting range: 0.0–100.0% (of the motor rated torque)	10.0%	<input type="radio"/>
P21.06	APR gain switchover threshold in speed command	0.0–100.0% (of the motor rated speed)	10.0%	<input type="radio"/>
P21.07	Smooth filter coefficient for gain	Smooth filter coefficient for APR gain switchover.	5	<input type="radio"/>

Function code	Name	Description	Default	Modify
	switchover	Setting range: 0–15		
P21.08	APR output limit	Position regulator output Value. When the APR output limit is 0, the APR is invalid, and no position control can be performed, however, speed control is valid. Setting range: 0.0–100.0% (of max. output frequency P00.03)	20.0%	○
P21.09	Positioning completion zone	When the position deviation is less than P21.09 , and the duration is greater than P21.10 , positioning completion signal will be outputted. Setting range: 0–1000	10	○
P21.10	Detection time for positioning completion	0.0–1000.0ms	10.0ms	○
P21.11	Numerator of position command ratio	Electronic gear ratio, used to adjust the corresponding relation between position command and actual running displacement. Setting range: 1–65535	1000	○
P21.12	Denominator of position command ratio	Setting range: 1–65535	1000	○
P21.13	Position feedforward gain	0.00–120.00% For pulse string reference only (position control)	100.00	○
P21.14	Position feedforward filter time constant	0.0–3200.0ms For pulse string reference only (position control)	3.0ms	○
P21.15	Position command filter time constant	Position feedforward filter time constant during the pulse string positioning. 0.0–3200.0ms	0.0ms	◎
P21.16	Digital positioning mode	Bit 0: Positioning mode 0: Relative position 1: Absolute position (Origin mode. This function is reserved.) Bit 1: Cyclic positioning setting. You can enable positioning through a terminal (function 55) or choose automatic cyclic positioning. Terminals	0	○

Function code	Name	Description	Default	Modify
		<p>support only the enabling of continuous positioning, and automatic cyclic positioning can be set to cyclic positioning or reciprocating positioning through bit 2 of P21.16.</p> <p>0: Terminal-based cyclic positioning 1: Automatic cyclic positioning</p> <p>Bit 2: Cyclic mode 0: Continuous 1: Reciprocating (support the automatic cyclic positioning)</p> <p>Bit 3: P21.17 digital setting mode. You can select incremental or position type. The incremental type indicates that P21.17 needs to be conducted again after each positioning is enabled. When the position reference bit command is enabled, the displacement is set through P21.17. When P21.17 is changed, new position is be positioned automatically.</p> <p>0: Incremental 1: Position type (do not support the continuous mode)</p> <p>Bit 4: Origin searching mode. 0: Search for the origin only for once 1: Search for the origin in every time of running</p> <p>Bit 5: Origin calibration mode. 0: Calibration in real time 1: One-time calibration</p> <p>Bit 6: Positioning completion signal setting. You can set the positioning completion signal in the pulse or electrical level form. The positioning completion signal is valid in the positioning completion signal holding time set in P21.25.</p> <p>0: Valid in the positioning completion signal holding time (P21.25) 1: Always valid</p> <p>Bit 7: First positioning setting. You can set whether the first positioning is performed when a running command is received. If no, the first</p>		

Function code	Name	Description	Default	Modify
		positioning is performed only after the positioning enabling terminal or automatic cyclic positioning is enabled. 0: Disable 1: Enable Bit 8: Positioning enabling signal setting (for terminal-based cyclic positioning). In the pulse form, after positioning is completed or in the first positioning, the jump edge of the positioning enabling terminal needs to be detected for performing positioning. In the electrical level mode, after positioning is completed or in the first positioning, positioning is performed after it is detected that the positioning enabling terminal is switched on. 0: Pulse signal 1: Electrical level signal Bit 9: Position source 0: Set by P21.17 1: PROFIBUS/CANopen/PROFINET communication Bit 10: Indicates whether to save encoder pulse count value at power-off 0: No 1: Yes Bit11: Reserved Bit 12: Positioning curve setting (Reserved) 0: Straight line 1: S curve		
P21.17	Position set in digital mode	Used to set the position for digital positioning. Actual position= P21.17 x P21.11 / P21.12 0–65535	0	○
P21.18	Positioning speed setting	0: Set by P21.19 1: AI1 2: AI2 3: AI3 4: High-speed pulse HDIA 5: High-speed pulse HDIB	0	○

Function code	Name	Description	Default	Modify
P21.19	Positioning speed set in digital mode	0–100.0% (of the max. frequency)	20.0%	<input type="radio"/>
P21.20	Positioning ACC time	Used to set the ACC/DEC time in the positioning process.	3.00s	<input type="radio"/>
P21.21	Positioning DEC time	Positioning ACC time means the time needed if the VFD speeds up from 0Hz to the max. output frequency (P00.03). Positioning DEC time means the time needed if the VFD speeds down from the max. output frequency (P00.03) to 0Hz. P21.20 setting range: 0.01–300.00s P21.21 setting range: 0.01–300.00s	3.00s	<input type="radio"/>
P21.22	Positioning holding time	Used to set the holding time after the destination position is reached. Setting range: 0.000–60.000s	0.100s	<input type="radio"/>
P21.23	Origin searching speed	0.00–50.00Hz	2.00Hz	<input type="radio"/>
P21.24	Origin bias	0–65535	0	<input type="radio"/>
P21.25	Positioning completion signal holding time	Time for holding the positioning completion signal. This parameter is also valid for the positioning in spindle orientation. Setting range: 0.000–60.000s	0.200s	<input type="radio"/>
P21.26	Pulse superposition	P21.26 : -9999–32767 P21.27 : 0–3000.0/ms	0	<input type="radio"/>
P21.27	Pulse superposition rate	The function is valid in the pulse speed reference (P00.06 =12) or pulse position mode (P21.00 =1).	8.0/ms	<input type="radio"/>
P21.28	ACC/DEC time after pulse inhibition	1. Input terminal function 68 (Enable the pulse superimposition) When the rising edge of the terminal is detected, add the value set in P21.26 to the set pulse value, and compensate to the pulse reference channel based on the pulse superposition speed set in P21.27 . 2. Input terminal function 67 (pulse increase) When the terminal is valid, superpose the pulse value to the pulse reference channel based on the pulse superposition speed set in P21.27 .	5.0s	<input type="radio"/>

Function code	Name	Description	Default	Modify
		<p>Note: Terminal filter P05.09 may affect the actual superposed value.</p> <p>For example: P21.27=1.0/ms P05.05=67</p> <p>When the S5 terminal input signal is 0.5 s, the actual superposed pulses = 500 pulses.</p> <p>3. Input terminal function 69 (pulse decrease) The time sequence of this function is same as the above. The difference is that this terminal is the pulse number that is superposed degressively.</p> <p>Note: The pulses mentioned above are superposed to A2 and B2 of pulse reference channel. Functions such as filtering and electronic gear are still valid for superposed pulses.</p> <p>4. Output terminal function 28 (during pulse superposition) During the pulse superposition, the output terminal is valid. After the pulse superposition is completed, the output terminal is invalid.</p>		
P21.29	Speed feedforward filtering time constant (pulse string-based speed mode)	Filter time constant detected by the pulse string when the speed reference source is set to the pulse string (P00.06 =12 or P00.07 =12). Setting range: 0–3200.0ms	10.0ms	<input type="radio"/>
P21.30	Numerator of the 2nd command ratio	1–65535	1000	<input type="radio"/>
P21.31	Pulse reference speed measuring method	0–2 0: Main control board 1: PG card	0	<input type="radio"/>
P21.32	Pulse reference feedforward	0x0–0x1 0: AI1 or HDIA	0x0	<input checked="" type="radio"/>

Function code	Name	Description	Default	Modify
	source	1: Pulses of channel F of the encoder		
P21.33	Set value of clearing encoder count	0-65535	0	⊙

P22 group—Spindle positioning

Function code	Name	Description	Default	Modify
P22.00	Spindle positioning mode selection	Bit0: Enable spindle positioning 0: Disable 1: Enable Bit1: Select spindle positioning reference point 0: Z pulse input 1: S2/S3/S4 terminal input Bit2: Search for reference point 0: Search the reference point only once 1: Search the reference point every time Bit3: Enable reference point calibration 0: Disable 1: Enable Bit4: Positioning mode selection 1 0: Set direction positioning 1: Near-by direction positioning Bit5: Positioning mode selection 2 0: Forward positioning 1: Reverse positioning Bit6: Zeroing command selection 0: Electric level mode 1: Pulse mode Bit7: Reference point calibration mode 0: Calibrate at the first time 1: Calibration in real time Bit8: Action selection after zeroing signal cancellation (electric level type) 0: Switch to speed mode 1: Position lock mode Bit9: Positioning completion signal selection 0: Electrical level signal	0	○

Function code	Name	Description	Default	Modify
		1: Pulse signal Bit10: Z pulse signal source 0: Motor 1: Spindle Bit11–15: Reserved		
P22.01	Speed of spindle orientation	During spindle orientation, the speed of the position point of orientation will be searched, and then it will switch over to position control orientation. Setting range: 0.00–100.00Hz	10.00Hz	<input type="radio"/>
P22.02	DEC time of spindle orientation	DEC time of spindle orientation. Spindle orientation deceleration time means the time needed for the VFD to decelerate from Max. output frequency (P00.03) to 0Hz. Setting range: 0.0–100.0s	3.0s	<input type="radio"/>
P22.03	Spindle zeroing position 0	You can select four spindle zeroing positions by terminals (functions 46 and 47). Setting range: 0–39999	0	<input type="radio"/>
P22.04	Spindle zeroing position 1	Setting range: 0–39999	0	<input type="radio"/>
P22.05	Spindle zeroing position 2	Setting range: 0–39999	0	<input type="radio"/>
P22.06	Spindle zeroing position 3	Setting range: 0–39999	0	<input type="radio"/>
P22.07	Spindle scale-division angle 1	You can select seven spindle scale-division angles by terminals (functions 48, 49, and 50). Setting range: 0.00–359.99	15.00	<input type="radio"/>
P22.08	Spindle scale-division angle 2	Setting range: 0.00–359.99	30.00	<input type="radio"/>
P22.09	Spindle scale-division angle 3	Setting range: 0.00–359.99	45.00	<input type="radio"/>
P22.10	Spindle scale-division angle 4	Setting range: 0.00–359.99	60.00	<input type="radio"/>
P22.11	Spindle scale-division	Setting range: 0.00–359.99	90.00	<input type="radio"/>

Function code	Name	Description	Default	Modify
	angle 5			
P22.12	Spindle scale-division angle 6	Setting range: 0.00–359.99	120.00	<input type="radio"/>
P22.13	Spindle scale-division angle 7	Setting range: 0.00–359.99	180.00	<input type="radio"/>
P22.14	Spindle drive ratio	Used to set the reduction ratio of the spindle and the mounting shaft of the encoder. Setting range: 0.000–30.000	1.000	<input type="radio"/>
P22.15	Spindle zero-point communication setting	P22.15 is used to set spindle zero-point offset. If the selected spindle zero point is P22.03 , the final spindle zero point is the sum of P22.03 and P22.15 . Setting range: 0–39999	0	<input type="radio"/>
P22.18	Rigid tapping selection	Ones place: Enabling selection 0: Disable (This function can be enabled through a terminal (configured with function 58) 1: Enable (internally) Tens place: Analog port selection 0: Disable 1: AI1 2: AI2 3: AI3	0x00	<input checked="" type="radio"/>
P22.19	Analog filter time of rigid tapping	0.0ms–1000.0ms	1.0ms	<input type="radio"/>
P22.20	Max. frequency of rigid tapping	0.00–400.00Hz	50.00Hz	<input type="radio"/>
P22.21	Corresponding frequency of analog zero drift of rigid tapping	0.00–10.00Hz	0.00Hz	<input type="radio"/>

P23 group—Vector control of motor 2

Function code	Name	Description	Default	Modify
P23.00	Speed-loop proportional gain	The parameters P23.00–P23.05 are applicable only to vector control mode. Below the switching	20.0	<input type="radio"/>

Function code	Name	Description	Default	Modify
	1	frequency 1 (P23.00), the speed-loop PI parameters are: P23.00 and P23.01 . Above the switching frequency 2 (P23.05), the speed-loop PI parameters are: P23.03 and P23.04 . PI parameters are obtained according to the linear change of two groups of parameters. See the following figure:		
P23.01	Speed-loop integral time 1	<p>The speed loop dynamic response characteristics of vector control can be adjusted by setting the proportional coefficient and integral time of speed regulator. Increasing proportional gain or reducing integral time can accelerate dynamic response of speed loop; however, if the proportional gain is too large or integral time is too small, system oscillation and overshoot may occur; if proportional gain is too small, stable oscillation or speed offset may occur.</p> <p>PI parameters have a close relationship with the inertia of the system. Adjust PI parameters depending on different loads to meet various demands.</p> <p>P23.00 setting range: 0.0–200.0 P23.01 setting range: 0.000–10.000s P23.02 setting range: 0.00Hz–P23.05 P23.03 setting range: 0.0–200.0 P23.04 setting range: 0.000–10.000s P23.05 setting range: P23.02–P00.03 (Max. output frequency)</p>	0.200s	<input type="radio"/>
P23.02	Low-point frequency for switching		5.00Hz	<input type="radio"/>
P23.03	Speed-loop proportional gain 2		20.0	<input type="radio"/>
P23.04	Speed-loop integral time 2		0.200s	<input type="radio"/>
P23.05	High-point frequency for switching		10.00Hz	<input type="radio"/>
P23.06	Speed-loop output filter	0–8 (corresponding to 0–2 ⁸ /10ms)	0	<input type="radio"/>
P23.07	Electromotive slip	Slip compensation coefficient is used to adjust	100%	<input type="radio"/>

Function code	Name	Description	Default	Modify
	compensation coefficient of vector control	the slip frequency of the vector control and improve the speed control accuracy of the system. Adjusting the parameter properly can control the speed steady-state error.		
P23.08	Braking slip compensation coefficient of vector control	Setting range: 50–200%	100%	<input type="radio"/>
P23.09	Current-loop proportional coefficient P	The two function codes impact the dynamic response speed and control accuracy of the system. Generally, you do not need to modify the two function codes.	1000	<input type="radio"/>
P23.10	Current-loop integral coefficient I	Applicable to SVC mode 0 (P00.00=0), SVC mode 1 (P00.00=1), and closed-loop vector control mode (P00.00=3). Setting range: 0–65535	1000	<input type="radio"/>
P23.11	Speed-loop differential gain	0–10.00s	0.00s	<input type="radio"/>
P23.12	High-frequency current-loop proportional coefficient	In the closed-loop vector control mode (P00.00=3), when the frequency is lower than the current-loop high-frequency switching threshold (P23.14), the current-loop PI parameters are P23.09 and P23.10; and when the frequency is higher than the current-loop high-frequency switching threshold, the current-loop PI parameters are P23.12 and P23.13.	1000	<input type="radio"/>
P23.13	High-frequency current-loop integral coefficient	high-frequency switching threshold, the current-loop PI parameters are P23.12 and P23.13.	1000	<input type="radio"/>
P23.14	Current-loop high-frequency switching threshold	P23.12 setting range: 0–65535 P23.13 setting range: 0–65535 P23.14 setting range: 0.0–100.0% (of the max. frequency)	100.0%	<input type="radio"/>
P23.15	Enabling PI parameter switchover for start/stop in vector mode	0–1 0: Disable 1: Enable If the function is enabled, PI parameters in group P03 are used for running; PI parameters in group P23 are used for stop.	0	<input checked="" type="radio"/>

P24 group—Encoder of motor 2

Function code	Name	Description	Default	Modify
P24.00	Encoder type display	0: Incremental encoder 1: Resolver-type encoder 2: Sin/Cos encoder 3: Endat absolute encoder	0	●
P24.01	Encoder pulse number	Number of pulses generated when the encoder revolves for one circle. Setting range: 0–16000	1024	◎
P24.02	Encoder direction	Ones place: AB direction 0: Forward 1: Reverse Tens place: Z pulse direction (reserved) 0: Forward 1: Reverse Hundreds: CD/UUVW pole signal direction 0: Forward 1: Reverse	0x000	◎
P24.03	Detection time of encoder offline fault Detection time of encoder offline fault.	Setting range: 0.0–10.0s	2.0s	○
P24.04	Detection time of encoder reversal fault	Detection time of encoder reversal fault. Setting range: 0.0–100.0s	0.8s	○
P24.05	Filter times of encoder detection	Setting range: 0x00 –0x99 Ones place: Low-speed filter time, corresponding to $2^{(0-9)} * 125\mu s$. Tens place: High-speed filter times, corresponding to $2^{(0-9)} * 125\mu s$.	0x33	○
P24.06	Speed ratio between encoder mounting shaft and motor	You need to set the function parameter when the encoder is not installed on the motor shaft and the drive ratio is not 1. Setting range: 0.001–65.535	1.000	○
P24.07	Control parameters of SM	Bit0: Enable Z pulse calibration Bit1: Enable encoder angle calibration Bit2: Enable SVC speed measurement	0x3	○

Function code	Name	Description	Default	Modify
		Bit3: Reserved Bit4: Reserved Bit5: Reserved Bit6: Enable the CD signal calibration Bit7: Reserved Bit8: Do not detect encoder faults during autotuning Bit9: Enable Z pulse detection optimization Bit10: Enable the initial Z pulse calibration optimization Bit12: Clear the Z pulse arrival signal after stop Bit13: Reserved Bit14: Detect the Z pulse after one turn of rotation Bit15: Reserved		
P24.08	Enable Z pulse offline detection	0x00–0x11 Ones place: Z pulse detection 0: Disable 1: Enable Tens place: UVW pulse detection (for SM) 0: Disable 1: Enable	0x10	<input type="radio"/>
P24.09	Initial angle of Z pulse	Relative electric angle between the encoder Z pulse and the motor pole position. Setting range: 0.00–359.99	0.00	<input type="radio"/>
P24.10	Pole initial angle	Relative electric angle between the encoder position and the motor pole position. Setting range: 0.00–359.99	0.00	<input type="radio"/>
P24.11	Autotuning pole initial angle	0–3 1: Rotary autotuning (DC braking) 2: Static autotuning (suitable for resolver-type encoder, sin/cos with CD signal feedback) 3: Rotary autotuning (initial angle identification) The pole initial angle obtained through rotary autotuning 1 is accurate. Rotary autotuning is recommended in most cases, in which the motor needs to be decoupled from the load or the motor load is light.	0	<input checked="" type="radio"/>

Function code	Name	Description	Default	Modify
P24.12	Speed measurement optimization selection	0: No optimization 1: Optimization mode 1 2: Optimization mode 2	1	☉
P24.13	CD signal zero offset gain	0-65535	0	○
P24.14	Encoder type selection	Ones place: Incremental encoder 0: without UVW 1: with UVW Tens place: Sin/Cos encoder 0: without CD signal 1: with CD signal	0x00	☉
P24.15	Speed measurement mode	0: Measuring speed by PG card 1: Locally measured through HDIA and HDIB. Only the 24V incremental encoders are supported. Note: HDI height measuring is implemented through the HDIA and HDIB and supports only incremental 24V encoders.	0	☉
P24.16	Frequency division coefficient	0-255 When the function parameter is set to 0 or 1, frequency division of 1:1 is implemented.	0	○
P24.17	Pulse filter handling selection	0x0000-0xFFFF Bit0: Enable/disable encoder input filter 0: No filter 1: Filter Bit1: Encoder signal filter mode 0: Self-adaptive filter 1: Use P24.18 filter parameter Bit2: Enable/disable encoder frequency-division output filter 0: No filter 1: Filter Bit3: Enable/disable pulse reference frequency-division output filter 0: No filter 1: Filter Bit4: Enable/disable pulse reference filter	0x0033	○

Function code	Name	Description	Default	Modify
		0: No filter 1: Filter Bit5: Pulse reference filter mode (valid when Bit4 is set to 1) 0: Self-adaptive filter 1: Use P24.19 filter parameter Bit6: Frequency-divided output source setting 0: Encoder signals 1: Pulse reference signals Bit7–15: Reserved		
P24.18	Encoder pulse filter width	0–63 The filter time is $P24.18 \times 0.25\mu s$. The value 0 or 1 indicates 0.25 μs .	2	<input type="radio"/>
P24.19	Pulse reference filter width	0–63 The filter time is $P24.19 \times 0.25\mu s$. The value 0 or 1 indicates 0.25 μs .	2	<input type="radio"/>
P24.20	Pulse number of pulse reference	0–65535	1024	<input checked="" type="radio"/>
P24.21	Enabling SM angle compensation	0–1	0	<input type="radio"/>
P24.22	Frequency point of speed measurement mode switchover	0–630.00Hz	1.00Hz	<input type="radio"/>
P24.23	Angle compensation coefficient	-200.0–200.0%	100.0%	<input type="radio"/>
P24.24	Motor pole pairs in initial pole angle autotuning	0–128	2	<input checked="" type="radio"/>

P25 group—I/O card input functions

Function code	Name	Description	Default	Modify
P25.00	HDI3 input type selection	0–1 0: HDI3 is high-speed pulse input 1: HDI3 is digital input	0	<input checked="" type="radio"/>

Function code	Name	Description	Default	Modify																																
P25.01	Function of S5	Same as P05	0	⊙																																
P25.02	Function of S6		0	⊙																																
P25.03	Function of S7		0	⊙																																
P25.04	Function of S8		0	⊙																																
P25.05	Function of S9		0	⊙																																
P25.06	Function of S10		0	⊙																																
P25.07	Function of S11		0	⊙																																
P25.08	Function of S12		0	⊙																																
P25.09	Function of HDI3			0	⊙																															
P25.10	Expansion card input terminal polarity	0x000–0x1FF	0x000	○																																
		<table border="1" style="width:100%; text-align:center;"> <tr><td></td><td></td><td></td><td>BIT8</td></tr> <tr><td></td><td></td><td></td><td>HDI3</td></tr> <tr><td></td><td></td><td></td><td></td></tr> <tr><td>BIT7</td><td>BIT6</td><td>BIT5</td><td>BIT4</td></tr> <tr><td>S12</td><td>S11</td><td>S10</td><td>S9</td></tr> <tr><td></td><td></td><td></td><td></td></tr> <tr><td>BIT3</td><td>BIT2</td><td>BIT1</td><td>BIT0</td></tr> <tr><td>S8</td><td>S7</td><td>S6</td><td>S5</td></tr> </table>						BIT8				HDI3					BIT7	BIT6	BIT5	BIT4	S12	S11	S10	S9					BIT3	BIT2	BIT1	BIT0	S8	S7	S6	S5
							BIT8																													
							HDI3																													
		BIT7			BIT6	BIT5	BIT4																													
S12	S11	S10	S9																																	
BIT3	BIT2	BIT1	BIT0																																	
S8	S7	S6	S5																																	
P25.11	Expansion card virtual terminal setting	0x000–0x1FF (0: Disable, 1: Enable)	0x000	⊙																																
		BIT0: S5 virtual terminal																																		
		BIT1: S6 virtual terminal																																		
		BIT2: S7 virtual terminal																																		
		BIT3: S8 virtual terminal																																		
P25.12	HDI3 switch-on delay	Used to specify the delay time corresponding to the electrical level changes when the programmable input terminals switch on or switch off.	0.000s	○																																
P25.13	HDI3 switch-off delay		0.000s	○																																
P25.14	S5 switch-on delay		0.000s	○																																
P25.15	S5 switch-off delay		0.000s	○																																
P25.16	S6 switch-on		0.000s	○																																

Function code	Name	Description	Default	Modify
	delay	Setting range: 0.000–50.000s		
P25.17	S6 switch-off delay		0.000s	<input type="radio"/>
P25.18	S7 switch-on delay		0.000s	<input type="radio"/>
P25.19	S7 switch-off delay		0.000s	<input type="radio"/>
P25.20	S8 switch-on delay		0.000s	<input type="radio"/>
P25.21	S8 switch-off delay		0.000s	<input type="radio"/>
P25.22	S9 switch-on delay		0.000s	<input type="radio"/>
P25.23	S9 switch-off delay		0.000s	<input type="radio"/>
P25.24	S10 switch-on delay		0.000s	<input type="radio"/>
P25.25	S10 switch-off delay		0.000s	<input type="radio"/>
P25.26	S11 switch-on delay		0.000s	<input type="radio"/>
P25.27	S11 switch-off delay		0.000s	<input type="radio"/>
P25.28	S12 switch-on delay		0.000s	<input type="radio"/>
P25.29	S12 switch-off delay	0.000s	<input type="radio"/>	
P25.30	AI3 lower limit	Used to define the relationship between the analog input voltage and its corresponding setting. When the analog input voltage exceeds the range from the upper limit to the lower limit, the upper limit or lower limit is used. When the analog input is current input, 0mA–20mA current corresponds to 0V–10V voltage. In different applications, 100.0% of the analog setting corresponds to different nominal values. See the descriptions of each application section	0.00V	<input type="radio"/>
P25.31	Corresponding setting of AI3 lower limit		0.0%	<input type="radio"/>
P25.32	AI3 upper limit		10.00V	<input type="radio"/>
P25.33	Corresponding setting of AI3 upper limit		100.0%	<input type="radio"/>

Function code	Name	Description	Default	Modify
P25.34	AI3 input filter time	for details. The following figure illustrates the cases of several settings:	0.030s	<input type="radio"/>
P25.35	AI4 lower limit		0.00V	<input type="radio"/>
P25.36	Corresponding setting of AI4 lower limit		0.0%	<input type="radio"/>
P25.37	AI4 upper limit		10.00V	<input type="radio"/>
P25.38	Corresponding setting of AI4 upper limit		100.0%	<input type="radio"/>
P25.39	AI4 input filter time		Input filter time: to adjust the sensitivity of analog input. Increasing the value properly can enhance analog input anti-interference but may reduce the sensitivity of analog input. Note: AI3 can support 0–10V/0–20mA input. When AI3 selects 0–20mA input, the corresponding voltage of 20mA is 10V. P25.30/P25.35 setting range: 0.00V– P25.32/P25.37 P25.31/P25.36 setting range: -300.0% –300.0% P25.32/P25.37 setting range: P25.30/P25.35 –10.00V P25.33/P25.38 setting range: -300.0% –300.0% P25.34/P25.39 setting range: 0.000s–10.000s	0.030s
P25.40	HDI3 high-speed pulse input function	0–1 0: Set input via frequency 1: Count	0	<input checked="" type="radio"/>
P25.41	Lower limit frequency of HDI3	0.000–P25.43 (kHz)	0.000	<input type="radio"/>
P25.42	Corresponding setting of lower limit frequency of HDI3	-300.0–300.0%	0.0	<input type="radio"/>
P25.43	Upper limit	P25.41–50.000kHz	50.000	<input type="radio"/>

Function code	Name	Description	Default	Modify
	frequency of HDI3			
P25.44	Corresponding setting of upper limit frequency of HDI3	-300.0~300.0%	100.0	○
P25.45	HDI3 frequency input filter time	0.000~10.000s	0.030	○
P25.46	AI3 input signal type	Range: 0~1 0: Voltage 1: Current	0	○
P25.48	S-terminal power signal selection (S terminal on I/O card 2)	0~1 0: DC (24~48V DC) 1: AC (24~48V AC)	0	◎

P26 group—I/O card output functions

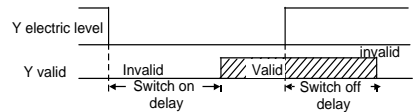
Function code	Name	Description	Default	Modify	
P26.02	Y2 output	Same as that for P06.01	0	○	
P26.04	RO3 output		0	○	
P26.05	RO4 output		0	○	
P26.12	Expansion card output terminal polarity	0x0000~0x7FFF RO10, RO9...RO3, HDO2, Y3, Y2 in sequence	0x0000	○	
P26.15	Y2 switch-on delay	Used to specify the delay time corresponding to the electrical level changes when the programmable output terminals switch on or switch off. 	0.000s	○	
P26.16	Y2 switch-off delay		0.000s	○	
P26.19	RO3 switch-on delay		0.000s	○	
P26.20	RO3 switch-off delay		0.000s	○	
P26.21	RO4 switch-on delay		Setting range: 0.000~50.000s	0.000s	○
P26.22	RO4 switch-off delay			0.000s	○

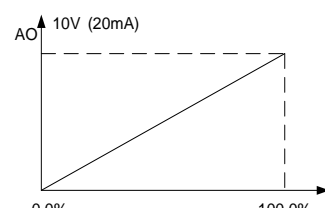
Function code	Name	Description	Default	Modify
P26.35	AO2 output	Same as the description for P06.14	0	<input type="radio"/>
P26.38	AO2 output lower limit	Used to define the relationship between the output value and analog output. When the output value exceeds the allowed range, the output uses the lower limit or upper limit. When the analog output is current output, 1mA equals 0.5V. In different cases, the corresponding analog output of 100% of the output value is different.	0.0%	<input type="radio"/>
P26.39	AO2 output corresponding to lower limit		0.00V	<input type="radio"/>
P26.40	AO2 output upper limit		100.0%	<input type="radio"/>
P26.41	AO2 output corresponding to upper limit		10.00V	<input type="radio"/>
P26.42	AO2 output filter time		 <p>Setting range of P26.38: -300.0%–P26.40 P26.39 setting range: 0.00V–10.00V Setting range of P26.40: P26.38–300.0% P26.41 setting range: 0.00V–10.00V Setting range of P26.42: 0.000s–10.000s</p>	0.000s

P27 group—Programmable expansion card functions

Function code	Name	Description	Default value	Modify
P27.00	Enabling the programmable card function	0–1 0: Disable 1: Enable	0	<input checked="" type="radio"/>
P27.01	I_WrP1	0–65535 Used to write a value to WrP1 of the programmable card.	0	<input type="radio"/>
P27.02	I_WrP2	0–65535 Used to write a value to WrP2 of the programmable card.	0	<input type="radio"/>
P27.03	I_WrP3	0–65535 Used to write a value to WrP3 of the programmable card.	0	<input type="radio"/>

Function code	Name	Description	Default value	Modify
P27.04	I_WrP4	0-65535 Used to write a value to WrP4 of the programmable card.	0	<input type="radio"/>
P27.05	I_WrP5	0-65535 Used to write a value to WrP5 of the programmable card.	0	<input type="radio"/>
P27.06	I_WrP6	0-65535 Used to write a value to WrP6 of the programmable card.	0	<input type="radio"/>
P27.07	I_WrP7	0-65535 Used to write a value to WrP7 of the programmable card.	0	<input type="radio"/>
P27.08	I_WrP8	0-65535 Used to write a value to WrP8 of the programmable card.	0	<input type="radio"/>
P27.09	I_WrP9	0-65535 Used to write a value to WrP9 of the programmable card.	0	<input type="radio"/>
P27.10	I_WrP10	0-65535 Used to write a value to WrP10 of the programmable card.	0	<input type="radio"/>
P27.11	Programmable card status	0-1 Used to display the status of the programmable card. 0: Stopped 1: Running	0	<input checked="" type="radio"/>
P27.12	C_MoP1	0-65535 Used to monitor/view the MoP1 value of the programmable card.	0	<input checked="" type="radio"/>
P27.13	C_MoP2	0-65535 Used to monitor/view the MoP2 value of the programmable card.	0	<input checked="" type="radio"/>
P27.14	C_MoP3	0-65535 Used to monitor/view the MoP3 value of the programmable card.	0	<input checked="" type="radio"/>
P27.15	C_MoP4	0-65535 Used to monitor/view the MoP4 value of the	0	<input checked="" type="radio"/>

Function code	Name	Description	Default value	Modify
		programmable card.		
P27.16	C_MoP5	0–65535 Used to monitor/view the MoP5 value of the programmable card.	0	●
P27.17	C_MoP6	0–65535 Used to monitor/view the MoP6 value of the programmable card.	0	●
P27.18	C_MoP7	0–65535 Used to monitor/view the MoP7 value of the programmable card.	0	●
P27.19	C_MoP8	0–65535 Used to monitor/view the MoP8 value of the programmable card.	0	●
P27.20	C_MoP9	0–65535 Used to monitor/view the MoP9 value of the programmable card.	0	●
P27.21	C_MoP10	0–65535 Used to monitor/view the MoP10 value of the programmable card.	0	●
P27.22	Digital input terminal status of programmable card	0x00–0x3F Bit5–Bit0 indicates PS6–PS1 respectively.	0x00	●
P27.23	Digital output terminal status of programmable card	0x0–0x3 Bit0 indicates PRO1, and Bit1 indicates PRO2.	0x0	●
P27.24	AI1 of the programmable card	0–10.00V/0.00–20.00mA AI1 value from the programmable card.	0	●
P27.25	AO1 of programmable card	0–10.00V/0.00–20.00mA AO1 value from the programmable card.	0	●
P27.26	Length of data sent by programmable card and PZD communication	0x00–0x28 Ones place: Quantity of data sent from the programmable card and VFD (that is, quantity of data sent from the programmable card + from	0x03	○

Function code	Name	Description	Default value	Modify
	object	VFD sending table 1 + from VFD sending table 2) 0: 0+24+60 1: 12+24+60 2: 24+24+60 3: 36+24+60 4: 48+24+60 5: 60+48+60 6: 72+24+60 7: 84+24+60 8: 96+96+96 Tens place: Card that communicates with the programmable card through PZD (valid only when the ones place of P27.26 is 5) 0: DP card 1: CANopen card 2: PN card Note: P27.26 can be changed at any time, but the change will only take effect after the re-power on.		
P27.27	Programmable card save function at power failure	0-1 0: Disable 1: Enable	1	⊙

P28 group—Master/slave control

Function code	Name	Description	Default	Modify
P28.00	Master/slave mode	0: Master/slave control is invalid. 1: The local device is the master. 2: The local device is the slave.	0	⊙
P28.01	Master/slave communication data selection	0: CAN 1: Reserved	0	⊙
P28.02	Master/slave control mode	Ones place: Master/slave running mode selection 0: Master/slave mode 0 The master and slave use speed control, with power balanced through droop control.	0x116	⊙

Function code	Name	Description	Default	Modify
		<p>1: Master/slave mode 1 (The master and slave must be in the same type of vector control. When the master is in speed control, the slave is forced into torque control.)</p> <p>2: Master/slave mode 2 The slave switches from speed mode (master/slave mode 0) to torque mode (master/slave mode 1) at a frequency point.</p> <p>3: Master/slave mode 3 (Reserved) (Both the master and slave adopt speed control, and the slave performs power balance depending on the speed loop integral result of the master.)</p> <p>4: Closed-loop master/slave mode (Master/slave mode 4) The master and slave must be equipped with encoders. The master and slave adopt speed control, using position pulse difference for speed correction.</p> <p>5: Master/slave mode 5 (Both the master and slave adopt closed-loop speed control, and the slave performs power balance depending on the speed loop of the master.)</p> <p>6: Master/slave mode 6 Used for master/slave height transfer, in which the master sends the measured height to the slave and the master and slave do not run synchronously. (You can check P94.05 to obtain the height sent from the master and P94.32 to obtain the height sent to the slave.)</p> <p>7: Master/slave mode 7 Used when the master is in speed control while the slave is in torque control, and the master and slave carry loads independently and use the same brake release control.</p> <p>Tens place: Slave start command source</p>		

Function code	Name	Description	Default	Modify
		0: Master 1: Determined by P00.01 Hundreds place: Whether to enable master/slave to send/receive data 0: Enable 1: Disable		
P28.03	Slave speed gain	It is a percentage of the master ramp frequency. When the master and slave are different in the DEC ratio: 0.0–500.0% When the master and slave are the same in the DEC ratio: 100.0%	100.0%	<input type="radio"/>
P28.04	Slave torque gain	It is a percentage of the set frequency of the master. When the master and slave are different in the motor power: 0.0–500.0% When the master and slave are the same in the motor power: 100.0%	100.0%	<input type="radio"/>
P28.05	Frequency point for switching between speed mode and torque mode in master/slave mode 2	0.00–10.00Hz	5.00Hz	<input type="radio"/>
P28.06	Number of slaves	0–15	1	<input checked="" type="radio"/>
P28.07	Master/slave transmission unit pulse ratio for position synchronization	0.00–100.00	1.00	<input type="radio"/>
P28.08	Position synchronization deviation deadzone setting	0–50000 When the position difference is greater than P28.08 , correction on the slave is valid.	50	<input type="radio"/>
P28.09	Position synchronization deviation	0–50000 When the position difference between the master and slave is greater than P28.09 , a	1000	<input type="radio"/>

Function code	Name	Description	Default	Modify
	threshold	master/slave position fault (ELS) is reported.		
P28.10	Position synchronization regulator output limit	0.0–100.0%	5.0%	<input type="radio"/>
P28.11	Position synchronization pulse count reset method	0–1 0: Automatic During stop, the position synchronization pulse count is automatically reset. 1: Terminal based If the input terminal selects the position synchronization pulse count reset function, the pulse count is automatically reset when there is signal input.	0	<input checked="" type="radio"/>
P28.12	Position synchronization proportional coefficient	0.000–10.000	0.005	<input type="radio"/>
P28.13	Position synchronization integral time	0.01–80.00	8.00s	<input type="radio"/>
P28.14	Position synchronization filtering time	0.00–10.00	0.05s	<input type="radio"/>
P28.15	Enabling the slave speed deviation window	0–1 0: Disable 1: Enable When the slave adopts the torque control mode, the speed deviation monitoring function can be enabled.	0	<input type="radio"/>
P28.16	Slave positive speed deviation window upper limit	0.00–50.00Hz When the actual speed is higher than the given speed, if the actual speed is higher than (Given speed + P28.16) and exceeds this upper limit, the speed has to be adjusted.	5.00Hz	<input type="radio"/>
P28.17	Slave negative speed deviation	0.00–50.00Hz When the actual speed is lower than the given	5.00Hz	<input type="radio"/>

Function code	Name	Description	Default	Modify
	window lower limit	speed, if the actual speed is lower than (Given speed - P28.17) and the window lower limit, the speed has to be adjusted.		
P28.18	Slave rotation speed regulation coefficient Kb	0–50000 Applicable only in master/slave mode 5.	100	<input type="radio"/>
P28.19	Rotation speed difference compensation coefficient Kc (Reserved)	0–50000 Applicable only in master/slave mode 5, in which there are only one master and one slave.	100	<input type="radio"/>
P28.20	Rotation speed difference compensation target setting (Reserved)	0–2 0: No 1: Compensate both the master and slave 2: Compensate only the slave	0	<input type="radio"/>
P28.21	CAN slave torque offset	-100.0–100.0% Valid when the slave uses torque control.	0	<input type="radio"/>
P28.22	Timeout time of readiness for master to wait slave to release brake	0.0–30.00s Valid when master/slave mode 7 is used.	0	<input type="radio"/>

P85 group—Anti-sway control

Function code	Name	Description	Default	Modify
P85.00	Enabling anti-sway	0–1 0: Disable anti-sway 1: Enable anti-sway 2: Enable sway reducing Note: The anti-sway function can be enabled by setting P85.00=1 or through terminal function selection. The sway reducing function can be enabled by setting P85.00=2 or through terminal function selection.	0	<input checked="" type="radio"/>
P85.01	Pendulum reduction mode	0–2 0: Pendulum reduction mode 0	0	<input checked="" type="radio"/>

Function code	Name	Description	Default	Modify
		1: Pendulum reduction mode 1 2: Pendulum reduction mode 2 Note: For the pendulum reduction duration, Pendulum reduction mode 2 > Pendulum reduction mode 1 ≥ Pendulum reduction mode 0		
P85.02	Rope length obtaining source	0-5 0: CAN master/slave card 1: AI1 2: AI2 3: AI3 4: HDIA 5: HDIB	0	☉
P85.03	Max. rope length	5.00-150.00m Note: It is used as the base value when P85.02 ranges from 1 to 5.	40.00	☉
P85.04	Height (rope length) compensation value	0.00-150.00m	0.00	☉
P85.05	K coefficient (Damping ratio calculation)	0-1000	400	☉
P85.06	Gear switchover filtering delay	0.000-10.000s	0.000	☉
P85.07	Anti-sway percentage	0-100	30	○
P85.08	Residual sway percentage	0-100	11	○
P85.09	ACC/DEC time of sway reducing at low gear	0.00-10.00s	2.00	○
P85.10	ACC/DEC time of sway reducing at medium gear	0.00-10.00s	3.00	○
P85.11	ACC/DEC time of sway reducing at	0.00-10.00s	4.00	○

Function code	Name	Description	Default	Modify
	high gear			
P85.12	Anti-sway and swing protection starting frequency	0.00–50.00Hz Applicable to pendulum reduction mode 0 (P85.01=0) and sway reducing mode (P85.00=2). When the set frequency change value is equal to or greater than P85.12, anti-sway or sway reducing is enabled; otherwise, normal ACC/DEC is enabled.	10.00	○

P86 group—Slewing control

Function code	Name	Description	Default	Modify
P86.00	Curve entrance frequency	1.00–25.00HZ	8.00HZ	◎
P86.01	Curve coefficient	10–100	70	◎
P86.02	Stop torque hold time 1	1.0–50.0s	16.0s	○
P86.03	Stop torque hold time 2	1.0–50.0s	6.0s	○
P86.04	Stop comparison frequency	0.00–50.00HZ The value 0.00Hz indicates no use. During stop, if the frequency is lower than P86.04, the low speed is valid.	0.00HZ	◎
P86.05	Low-speed segment curve selection	0–1 Used when the curve mode P01.05=2 is used. When the stop frequency is lower than P86.04 (low-speed function is valid): 0: The low-speed segment curve uses the time specified by P86.03. 1: The low-speed segment does not use the curve manner but uses the straight line manner.	0	◎
P86.06	Enabling discontinuous curves	0–1 0: Continuous 1: Discontinuous	0	◎
P86.08	Gear switchover ACC curve time	0.0–30.0s	10.0s	○
P86.09	ACC curve entrance	0–100% Relative to the set frequency	90%	◎

Function code	Name	Description	Default	Modify
	frequency ratio of gear switchover			
P86.10	Gear switchover DEC curve time	0.0–30.0s The value 0 indicates no use of gear switchover curves.	0.0s	○
P86.11	DEC curve entrance frequency ratio of gear switchover	0.0–50.0% Relative to the rated frequency	8.0%	◎
P86.12	Direction change switchover mode selection	0: Normal mode 1: Quick switchover mode 1 (single tap-braking)	0	◎
P86.13	Direction change switchover basis DEC time	0.0–50.0s	8.0s	○
P86.14	Lagging value of direction change switchover basis time	100%–500% (Used together with multi-step speed running)	100%	○
P86.15	Direction change switchover retaining frequency	0.00–15.00HZ	3.50Hz	◎
P86.16	Hold time 1 of direction change switchover frequency	0.000–50.000s	4.000s	○
P86.17	Hold time 2 of direction change switchover frequency	0.000–50.000s	3.000s	○
P86.18	Direction change switchover comparison frequency	0.00–50.00HZ During direction change switchover, if the entrance point is lower than P86.18, P86.17 is used.	0.00Hz	◎
P86.21	Enabling reverse-rotation	0–2 If this function is enabled, the reverse-gear stop	0	◎

Function code	Name	Description	Default	Modify
	braking	DEC time is used during reverse-gear stop. 0: Disable 1: Enable. Reverse-rotation braking is used as usual. 2: Enable. The retaining frequency is added during reverse-rotation braking. That is, if the frequency is higher than P86.23 when reverse braking is valid, P86.25 is kept for P86.24.		
P86.22	Reverse-rotation braking duration	0–50.0s	8.0s	<input type="radio"/>
P86.23	Reverse-rotation braking comparison frequency	0.00–50.00HZ	15.00Hz	<input checked="" type="radio"/>
P86.24	Reverse-rotation braking retaining frequency hold time	0.000–50.000s	1.500s	<input type="radio"/>
P86.25	Reverse-rotation braking retaining frequency	0.00–50.00HZ	15.00Hz	<input checked="" type="radio"/>
P86.28	Enabling wind resistance	0–1 0: Disable 1: Enable	0	<input checked="" type="radio"/>
P86.29	ACC phase mode	0–1 0: Clearing the droop value through auto adaptation 1: Setting the droop value change rate manually	0	<input checked="" type="radio"/>
P86.30	Droop value change rate at ACC phase	0.00–20.00Hz/s	1.00	<input type="radio"/>
P86.31	DEC phase mode	0–1 0: Quick compensating for the droop value 1: Setting the droop value change rate manually	0	<input checked="" type="radio"/>
P86.32	Droop value change rate at	0–20.00 Hz/s	1.00	<input type="radio"/>

Function code	Name	Description	Default	Modify
	DEC phase			

P89 group—Parameters of motor 3

Function code	Name	Description	Default	Modify
P89.00	Type of motor 3	0: Asynchronous motor (AM) 1: Synchronous motor (SM)	0	☉
P89.01	Rated power of AM 3	0.1–3000.0kW	Model depended	☉
P89.02	Rated frequency of AM 3	0.01Hz– <u>P00.03</u> (Max. output frequency)	50.00Hz	☉
P89.03	Rated speed of AM 3	1–36000rpm	Model depended	☉
P89.04	Rated voltage of AM 3	0–1200V	Model depended	☉
P89.05	Rated current of AM 3	0.8–6000.0A	Model depended	☉
P89.06	Stator resistance of AM 3	0.001–65.535Ω	Model depended	○
P89.07	Rotor resistance of AM 3	0.001–65.535Ω	Model depended	○
P89.08	Leakage inductance of AM 3	0.1–6553.5mH	Model depended	○
P89.09	Mutual inductance of AM 3	0.1–6553.5mH	Model depended	○
P89.10	No-load current of AM 3	0.1–6553.5A	Model depended	○
P89.11	Magnetic saturation coefficient 1 of iron core of AM 3	0.0–100.0%	80.0%	○
P89.12	Magnetic saturation coefficient 2 of iron core of AM 3	0.0–100.0%	68.0%	○
P89.13	Magnetic saturation	0.0–100.0%	57.0%	○

Function code	Name	Description	Default	Modify
	coefficient 3 of iron core of AM 3			
P89.14	Magnetic saturation coefficient 4 of iron core of AM 3	0.0–100.0%	40.0%	○
P89.15	Rated power of SM 3	0.1–3000.0kW	Model depended	◎
P89.16	Rated frequency of SM 3	0.01Hz–P00.03 (Max. output frequency)	50.00Hz	◎
P89.17	Number of pole pairs of SM 3	1–128	2	◎
P89.18	Rated voltage of SM 3	0–1200V	Model depended	◎
P89.19	Rated current of SM 3	0.8–6000.0A	Model depended	◎
P89.20	Stator resistance of SM 3	0.001–65.535Ω	Model depended	○
P89.21	Direct-axis inductance of SM 3	0.01–655.35mH	Model depended	○
P89.22	Quadrature-axis inductance of SM 3	0.01–655.35mH	Model depended	○
P89.23	Counter-emf constant of SM 3	0–10000V	300	○
P89.24	Initial pole position of SM 3 (reserved)	0–0xFFFF	0x0000	●
P89.25	Identification current of SM 2 (reserved)	0%–50% (of the motor rated current)	10%	●
P89.26	Overload protection of motor 3	0: No protection 1: Common motor (with low-speed compensation) 2: Frequency-variable motor (without low-speed compensation)	2	◎

Function code	Name	Description	Default	Modify
P89.27	Overload protection coefficient of motor 3	20.0%–120.0%	100.0%	<input type="radio"/>
P89.28	Power display calibration coefficient of motor 3	0.00–3.00	1.00	<input type="radio"/>
P89.29	Parameter display of motor 3	0: Display by motor type 1: Display all	0	<input type="radio"/>
P89.30	System inertia of motor 3	0–30.000kgm ²	0.000	<input type="radio"/>
P89.31	Speed control mode switchover of motor 3	0: No switchover. This indicates that motor 3 uses P00.00 of motor 1. 1: Switch to SVC1 2: Switch to VF 3: Switch to FVC	0	<input checked="" type="radio"/>

P90 group—Functions special for cranes

Function code	Name	Description	Default	Modify
P90.00	Hoisting application macro setting	0–18 0: Common application mode 1: Lifting mode 1 (in open-loop vector control)	0	<input checked="" type="radio"/>
P90.01	Terminal-switched application macro setting	2: Lifting mode 2 (in closed-loop vector control) 3: Horizontal moving mode (in space voltage vector control) 4: Tower crane slewing mode 5: Conical motor application mode 6: User-defined application macro 1 (when P90.02=1) 7: User-defined application macro 2 (when P90.02=2) 8: User-defined application macro 3 (when P90.02=3) 9: Lifting mode 3 (in space voltage vector control) 10: Construction elevator mode 11: Closed-loop winching (for lifting in mineral	0	<input checked="" type="radio"/>

Function code	Name	Description	Default	Modify
		wells and winches) 12: Open-loop winching (for lifting in mineral wells and winches) 13: Construction elevator mode 2 (for medium-speed elevator application) 14: Tower crane slewing without vortex in closed-loop vector control 15: Tower crane slewing without vortex in space voltage vector control 16–18: Reserved		
P90.02	User-defined application macro setting	0–3 1: Enter the settings of user-defined application macro 1 2: Enter the settings of user-defined application macro 2 3: Enter the settings of user-defined application macro 3	0	⊙
P90.03	Method for terminals to switch application macros	0–5 0: No switchover 1: Switch from motor 1 to motor 2 When the S terminal selects function 35 and takes effect, and P90.03=1, the macro parameter is switched from P90.00 to P90.01, and motor parameters are automatically switched. 2: Switch from motor 1 to motor 3 When the S terminal selects function 88 and takes effect, and P90.03=2, the macro parameter is switched from P90.00 to P90.01, and motor parameters are automatically switched. 3: Switch from the master to the slave When the S terminal selects function 72 and takes effect, and P90.03=3, the macro parameter is switched from P90.00 to P90.01, and the master/slave switchover is automatically performed. 4: Switch from the slave to the master When the S terminal selects function 71 and	0	⊙

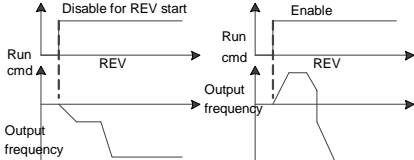
Function code	Name	Description	Default	Modify
		<p>takes effect, and P90.03=4, the macro parameter is switched from P90.00 to P90.01, and the master/slave switchover is automatically performed.</p> <p>5: Switch to SVC1 control (open-loop vector control 1)</p> <p>When P90.03=5, P90.00 must be 2, while P90.01 must be 1; alternatively, P90.00 must be 11, while P90.01 must be 12. Only control mode can be switched, and the S terminal selects function 62 and takes effect.</p> <p>Note: When P90.03=1 or 2, function macros can be switched over through communication, of which mode is set by P08.31.</p>		
P90.04	Enabling brake-oriented logic	<p>0–1</p> <p>0: The brake is controlled by an external controller.</p> <p>1: The brake is controlled by the VFD.</p>	0	⊙
P90.05	Enabling forward torque for reverse-running start/stop	<p>0x00–0x11</p> <p>Ones place: indicates whether to enable forward torque for reverse-running start</p> <p>0: Disable (The reverse-running start direction complies with the command.)</p> <p>1: Enable (The reverse-running start direction is always the forward-running direction.)</p>  <p>Tens place: indicates whether to enable forward torque for reverse-running stop</p> <p>0: Disable</p>	0x00	⊙

Function code	Name	Description	Default	Modify																																																	
		<p>(The reverse-running stop direction complies with the command.)</p> <p>1: Enable</p> <p>(The reverse-running stop direction is always the forward-running direction.)</p> <p>When reverse startup or forward torque for stop is enabled, the VFD first runs in forward direction and then runs in reverse direction, so as to ensure enough torque to drive the load.</p>																																																			
P90.06	Graded multi-step speed reference 0	<p>Graded reference is a speed reference method for hoisting applications. Graded reference supports the graded operating lever mode and graded remote-control mode. Graded reference can implement 6-step speeds by combing the five graded multi-step reference terminals. The combination methods are as follows:</p> <p>Graded reference terminal</p> <table border="1"> <thead> <tr> <th>Trml 1</th> <th>Trml 2</th> <th>Trml 3</th> <th>Trml 4</th> <th>Trml 5</th> <th>Speed setting</th> <th>Code</th> </tr> </thead> <tbody> <tr> <td>OFF</td> <td>OFF</td> <td>OFF</td> <td>OFF</td> <td>OFF</td> <td>Graded setting 0</td> <td>P90.06</td> </tr> <tr> <td>ON</td> <td>OFF</td> <td>OFF</td> <td>OFF</td> <td>OFF</td> <td>Graded setting 1</td> <td>P90.07</td> </tr> <tr> <td>ON</td> <td>ON</td> <td>OFF</td> <td>OFF</td> <td>OFF</td> <td>Graded setting 2</td> <td>P90.08</td> </tr> <tr> <td>ON</td> <td>ON</td> <td>ON</td> <td>OFF</td> <td>OFF</td> <td>Graded setting 3</td> <td>P90.09</td> </tr> <tr> <td>ON</td> <td>ON</td> <td>ON</td> <td>ON</td> <td>OFF</td> <td>Graded setting 4</td> <td>P90.10</td> </tr> <tr> <td>ON</td> <td>ON</td> <td>ON</td> <td>ON</td> <td>ON</td> <td>Graded setting 5</td> <td>P90.11</td> </tr> </tbody> </table> <p>Set P00.06=15 or P00.07=15. The multi-step speed setting terminals are specified by P05 or P25, which can select functions 77–8. The speeds are specified by P90.06–P90.11 (P00.03: max. frequency).</p>	Trml 1	Trml 2	Trml 3	Trml 4	Trml 5	Speed setting	Code	OFF	OFF	OFF	OFF	OFF	Graded setting 0	P90.06	ON	OFF	OFF	OFF	OFF	Graded setting 1	P90.07	ON	ON	OFF	OFF	OFF	Graded setting 2	P90.08	ON	ON	ON	OFF	OFF	Graded setting 3	P90.09	ON	ON	ON	ON	OFF	Graded setting 4	P90.10	ON	ON	ON	ON	ON	Graded setting 5	P90.11	0.0%	<input type="radio"/>
Trml 1	Trml 2		Trml 3	Trml 4	Trml 5	Speed setting	Code																																														
OFF	OFF		OFF	OFF	OFF	Graded setting 0	P90.06																																														
ON	OFF		OFF	OFF	OFF	Graded setting 1	P90.07																																														
ON	ON		OFF	OFF	OFF	Graded setting 2	P90.08																																														
ON	ON	ON	OFF	OFF	Graded setting 3	P90.09																																															
ON	ON	ON	ON	OFF	Graded setting 4	P90.10																																															
ON	ON	ON	ON	ON	Graded setting 5	P90.11																																															
P90.07	Graded multi-step speed reference 1	0.0%	<input type="radio"/>																																																		
P90.08	Graded multi-step speed reference 2	0.0%	<input type="radio"/>																																																		
P90.09	Graded multi-step speed reference 3	0.0%	<input type="radio"/>																																																		
P90.10	Graded multi-step speed reference 4	0.0%	<input type="radio"/>																																																		
P90.11	Graded multi-step speed reference 5	0.0%	<input type="radio"/>																																																		

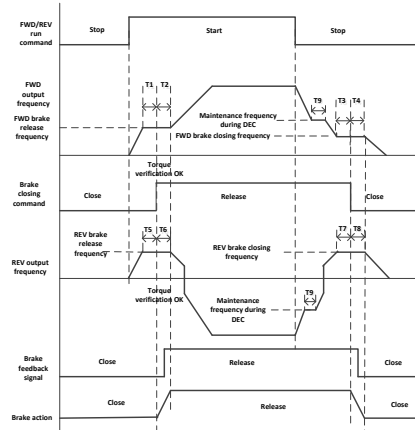
Function code	Name	Description	Default	Modify	
		P90.06 , P90.07 , P90.08 , P90.09 , P90.10 , P90.11 setting range: 0.0%–100.0% Note: The multi-step settings of a higher grade can be closed only after the multi-step settings of all lower grades are closed.			
P90.12	Forward brake release current	Brake timing diagram in V/F mode: 	0.0%	○	
P90.13	Reverse brake release current		0.0%	○	
P90.14	Forward brake release torque		0.0%	○	
P90.15	Reverse brake release torque		0.0%	○	
P90.16	Forward brake release frequency		3.00Hz	○	
P90.17	Reverse brake release frequency		3.00Hz	○	
P90.18	Forward brake closing frequency		3.00Hz	○	
P90.19	Reverse brake closing frequency		3.00Hz	○	
P90.20	Delay before forward brake release		Use forward-running timing sequence as example:	0.300s	○
P90.21	Delay before reverse brake release		Start: When the VFD is in standby state, the brake output signal is closed. After receiving the running command, the VFD accelerates with the target frequency P90.16 . In addition, the VFD starts torque verification, if the verification is OK (condition: output current >= P90.12) (it is P90.13 in reverse running) and output torque >= P90.14 (it is P90.15 in reverse during running), output frequency is at least equal to P90.16 (it is P90.17 in reverse running), the delay before forward brake release starts, and the VFD outputs the brake release signal when P90.20 (or P90.21 in reverse running) is reached. Then the delay after forward brake release starts. The	0.000s	○
P90.22	Delay after forward brake release		0.300s	○	
P90.23	Delay after reverse brake release		0.000s	○	
P90.24	Delay before forward brake closing		0.300s	○	
P90.25	Delay before reverse brake		0.000s	○	

Function code	Name	Description	Default	Modify
	closing	VFD normally accelerates to the set frequency within the time specified by P90.22 (or P90.23 in reverse running).		
P90.26	Delay after forward brake closing	Stop: To prevent hook slip, sufficient output torque must be ensured before brake is closed.	0.300s	<input type="radio"/>
P90.27	Delay after reverse brake closing	After receiving the stop command, the VFD decelerates to P90.28 with a maintenance frequency within P90.29 . When output frequency <= P90.18 (or P90.19 in reverse running), the delay before brake release starts.	0.000s	<input type="radio"/>
P90.28	Retaining frequency for stop	When the delay reaches P90.24 (or P90.25 in reverse running), the VFD outputs brake closing signal. The delay after brake release starts. The VFD decelerates to zero and stops within the time P90.26 (or P90.27 in reverse running).	5.00Hz	<input type="radio"/>
P90.29	Retaining frequency hold time for stop	P90.12 , P90.13 setting range: 0.0–200.0% (of the motor rated current) P90.14 , 0.15 setting range: 0.0–200.0%(of the motor rated current) P90.16 , 90.17 , P90.18 , P90.19 setting range: 0.00–20.00Hz P90.20 , P90.21 , P90.22 , P90.23 , P90.24 , P90.25 , P90.26 , P90.27 setting range: 0.000–5.000s Note: If reverse-running delay is 0, the forward-running delay is used. P90.28 setting range: 0.00–50.00Hz P90.29 setting range: 0.000–5.000s P90.30 setting range: 0.000–10.000s	0.000s	<input type="radio"/>
P90.30	Torque verification fault detection time	P90.12 , P90.13 setting range: 0.0–200.0% (of the motor rated current) P90.14 , 0.15 setting range: 0.0–200.0%(of the motor rated current) P90.16 , 90.17 , P90.18 , P90.19 setting range: 0.00–20.00Hz P90.20 , P90.21 , P90.22 , P90.23 , P90.24 , P90.25 , P90.26 , P90.27 setting range: 0.000–5.000s Note: If reverse-running delay is 0, the forward-running delay is used. P90.28 setting range: 0.00–50.00Hz P90.29 setting range: 0.000–5.000s P90.30 setting range: 0.000–10.000s	6.000s	<input type="radio"/>
P90.31	Enabling the monitoring on brake status	P90.31 setting range: 0–1 0: Disable 1: Enable the brake current monitoring (and brake feedback detection).	0	<input checked="" type="radio"/>
P90.32	Brake feedback exception delay (brake feedback detection time)	When the function is disabled, no brake feedback fault is reported. After it is enabled, brake status can be monitored.	1.000s	<input type="radio"/>
P90.33	Brake monitoring current threshold	In open-loop mode: If the actual brake status is different from the S-terminal given brake	100.0%	<input type="radio"/>
P90.34	Enabling speed		0	<input checked="" type="radio"/>

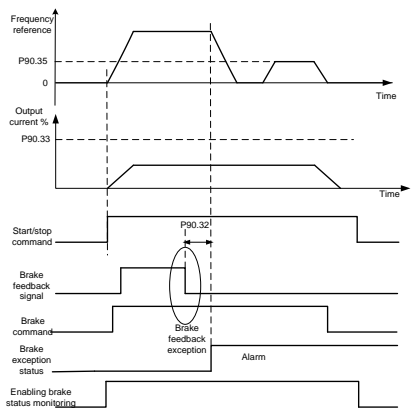
Function code	Name	Description	Default	Modify
P90.35	reference under brake status error Speed reference under brake status error	<p>feedback signal during running or stop, the brake feedback fault (FAE) is reported after the brake feedback exception delay P90.32.</p> <p>In closed-loop mode: During the stop, if a brake feedback exception occurs, the brake feedback fault (FAE) is reported after the brake feedback exception delay P90.32.</p> <p>During running, if a brake feedback exception occurs, the current is monitored after the brake feedback exception delay P90.32. If the present current is less than the monitored current, it is considered that the brake is not closed, and the action specified by P90.34 is performed. If P90.34=0, the VFD directly reports the brake feedback fault (FAE). If P90.34=1, the VFD opens the brake and runs at the speed specified by 0.35, and reports the brake feedback alarm (A-FA).</p>  <p>In closed-loop mode: During running, if a brake feedback exception occurs, the VFD starts monitoring current after the brake feedback exception delay P90.32. If the present current is greater than the brake monitoring current, the present actual frequency is checked. If the</p>	5.00Hz	○

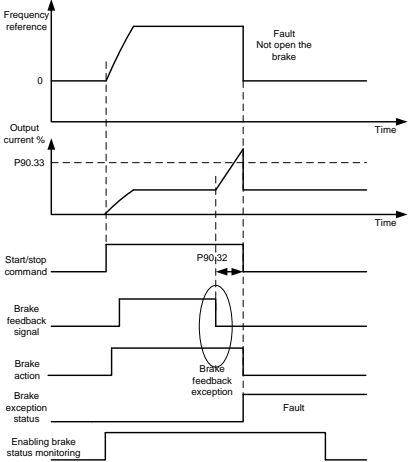
Function code	Name	Description	Default	Modify
		<p>actual frequency is lower than the forward brake frequency during forward rotating or the actual frequency is lower than the reverse brake frequency during reverse rotating, it is considered that the brake has been closed, the brake feedback fault (FAE) is reported.</p>  <p>P90.32 setting range: 0.00–20.000s P90.33 setting range: 0.0%–200.0% (100.0% corresponding to the motor rated current) P90.34 setting range: 0–1 0: Disable (Report the brake feedback fault FAE directly) 1: Enable brake status error speed giving (Report the brake feedback alarm A-FA simultaneously) P90.35 setting range: 0.00–50.00Hz</p>		
P90.36	Jog braking type	0x00–0x11 Ones place: Brake release type 0: Same as hoisting-oriented brake release frequency 1: Same as jog frequency Tens place: Brake closing type 0: Same as hoisting-oriented brake closing	0x00	☉

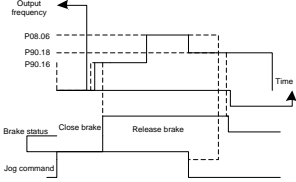
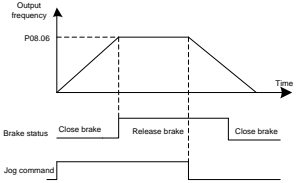
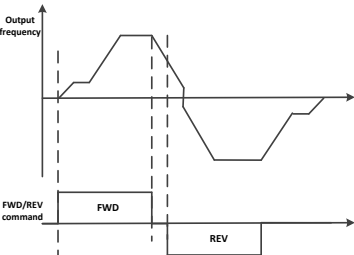
Function code	Name	Description	Default	Modify
		<p>frequency</p> <p>1: Same as jog frequency</p> <p>Same as hoisting-oriented brake release frequency:</p>  <p>Same as jog frequency:</p> 		
P90.37	Brake selection for forward/reverse switchover	<p>0—1</p> <p>0: No switchover</p> <p>1: Switchover</p> <p>When P90.37=0, the switchover is performed directly, and the brake does not act.</p>  <p>When P90.37=1, during the switchover, the VFD decelerates with braking to stop, and then opens the brake to run in reverse direction.</p>	0	©

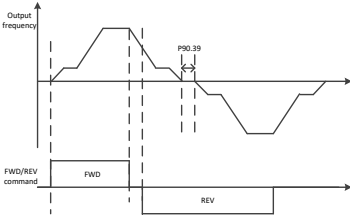
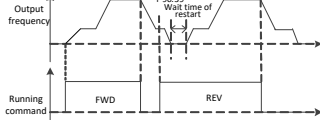
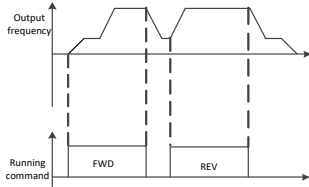
Function code	Name	Description	Default	Modify
				
P90.38	Restart selection during braking	<p>P90.38 setting range: 0–1</p> <p>0: No restart during braking</p>	0	☉
P90.39	Wait time for restart	 <p>During the stop, if the brake closing command has been output, the system does not accept any new startup commands, and it can be restarted with a wait time of P90.39 after the brake is closed and VFD stops.</p> <p>1: Restart allowed during braking</p>  <p>Though the brake closing command has been output during stop, the VFD accepts a new start command.</p> <p>P90.39 setting range: 0.0–10.0s</p>	0.5s	☉
P90.40	Braking method in open-loop vector control	<p>0–3</p> <p>0: Common mode</p> <p>1: Torque mode with limit 1 The limit is specified by P90.41.</p> <p>2: Torque/speed switchover mode 1 (boost with braking)</p> <p>It is used when P90.04=1 since the brake is</p>	0	☉

Function code	Name	Description	Default	Modify
		involved. When the brake is opened, the speed mode is automatically used. 3: Torque/speed switchover mode 2 (horizontal moving) Since the brake is not involved, the torque/speed switchover is set through P90.44. The set frequency must be greater than P90.44.		
P90.41	Torque limit 1 in open-loop vector control	Setting range: 0.0–300.0% (of the motor rated current) (P90.40=1 Torque limit mode)	120.0%	<input type="radio"/>
P90.42	Torque setting for brake release	0.0–200.0% During the running, when the torque feedback value is equal to or greater than P90.42, brake release timing is entered. (It is valid only when P90.04=1, which indicates the brake is controlled by the VFD, and the VFD uses the torque mode.)	50.0%	<input type="radio"/>
P90.44	Brake closing delay after stop DC braking starts	0.00–50.00HZ Used in torque/speed switchover mode 2	8.00Hz	<input checked="" type="radio"/>
P90.45	Torque verification mode	0: Mode 0 1: Mode 1	0	<input checked="" type="radio"/>
P90.46	ACC/DEC time switchover selection for REV rotation	0: No switchover. (Same as ACC/DEC time for FWD rotation.) 1: Switch to the DEC time. (P08.05 is used.) 2: Switch the ACC/DEC time. (P08.04 and P08.05 are used.)	0	<input checked="" type="radio"/>

P91 group—Functions special for cranes

Function code	Name	Description	Default	Modify
P91.00	Enabling the conical motor function	The conical motor does not require external braking since it implements braking by using internal magnetic flux control. During start, the starting frequency needs to be increased for brake release. During stop, quick demagnetizing needs to be implemented to prevent slip in case of overdue brake closing.	0	<input checked="" type="radio"/>
P91.01	Conical motor ACC process voltage coefficient K1		120.0%	<input type="radio"/>

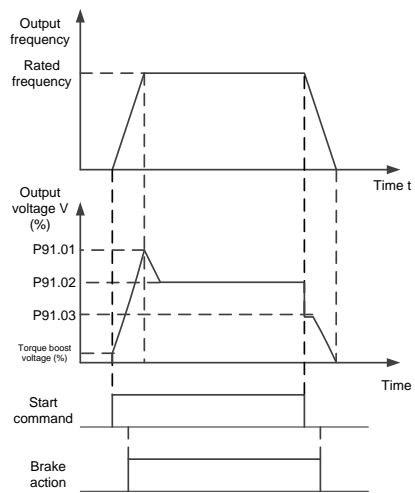
Function code	Name	Description	Default	Modify
P91.02	Conical motor constant process voltage coefficient K2	<p>P91.00 setting range: 0–1</p> <p>0: Disable 1: Enable</p> <p>P91.00=0: Disable. Normal voltage curves are used.</p> <p>P91.00=1: Conical motor voltage curves are used.</p> <p>P91.01 setting range: P91.02–150.0% (100.0% corresponds to the motor rated voltage.)</p> <p>P91.02 setting range: P91.03–P91.01</p> <p>P91.03 setting range: 0.0–P91.02</p>	100.0%	<input type="radio"/>
P91.03	Conical motor DEC process voltage coefficient K3	 <p>The conical motor function is used simultaneously with the multi-dot V/F function.</p>	80.0%	<input type="radio"/>

Function code	Name	Description	Default	Modify
		<p>The conical motor function is used simultaneously with the multi-dot V/F function.</p> <p>Note: The torque boost voltage is related to P04.01. The I/F mode is not applicable to conical motors.</p>		
P91.04	Contactor control selection	0–1 0: Controlled by an external controller 1: Controlled by the VFD	0	☉
P91.05	Contactor feedback detection time	0.00–20.000s	1.000s	☉
P91.06	Enabling operating lever zero point position detection	0x00–0x11 Ones place: 0: Disable zero point position detection 1: Enable zero point position detection Tens place: 0: Do not detect AI2 after zero position detection 1: Detect AI2 after zero position detection	0	☉
P91.07	Operating lever zero point position delay	After the zero position detection signal is enabled, the terminal zero position signal is given in stop state, the zero position detection is completed (valid) with a delay specified by P91.07 , the zero position signal is released, and the VFD runs only after being given with the	0.300s	○

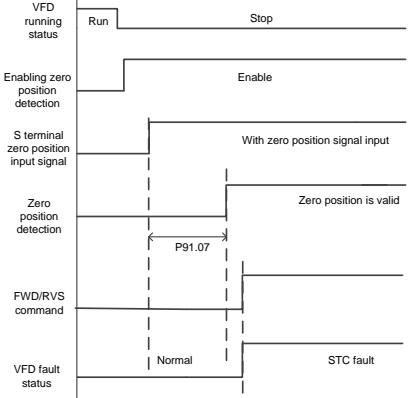
Function code	Name	Description	Default	Modify
		<p>running command. After the zero position signal detection takes effect, if both the zero position signal and running command signal are detected, the operating lever zero position fault STC is reported. If the running command is given during zero position detection, the VFD does not respond. If both the zero position signal and running command signal still exist after zero position detection, the operating lever zero position fault STC is also reported. If the zero position signal is removed suddenly during zero position detection, the VFD does not respond to the running command since zero position detection is incomplete.</p>  <p>The diagram shows the following sequence of events:</p> <ul style="list-style-type: none"> VFD running status transitions from Run to Stop. Enabling zero position detection signal becomes active (Enable). S terminal zero position input signal becomes active (With zero position signal input). Zero position detection starts, with a delay time P91.07. Zero position is valid. FWD/RVS command becomes active. VFD fault status transitions from Normal to STC fault. <p>After the VFD stops, the VFD starts zero position detection. When the zero position detection delay is reached, if the detection finds that A12 is greater than 1.00V, the analog speed reference deviation fault AdE is reported.</p>		

Function code	Name	Description	Default	Modify
		<p>Setting range: 0.000–10.000s</p>		
P91.08	Speed regulation selection with light/heavy load	<p>0–5</p> <p>0: Disable</p> <p>1: Constant power speed boost</p> <p>2: Constant power speed limit</p> <p>3: Stepped speed limit</p> <p>4: Light load speed boost 1 (by set current and frequency)</p> <p>5: Speed boost through external terminal signal</p>	0	☉
P91.09	Light-load speed-boost target frequency setting	<p>P91.08=4: Light load speed boost mode 1 (according to set current and frequency)</p>	70.00Hz	○
P91.10	Light-load speed-boost detection frequency		90.0%	○
P91.11	Light-load speed-boost current detection time		1.000s	○
P91.12	FWD light-load speed-boost current detection	<p>Light load speed boost after current verification</p>	60.0%	○

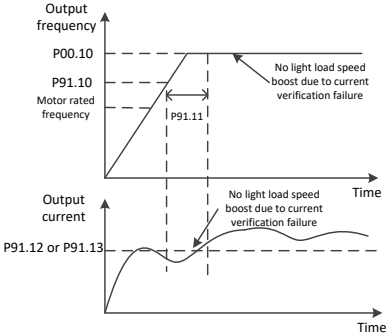
Function code	Name	Description	Default	Modify
	value	SUCCESS		
P91.13	REV light-load speed-boost current detection value	 <p>No light load speed boost due to current verification failure</p> <p>If light load speed boost mode 1 is enabled, processing for light load speed boost is performed only when the set frequency is no less than P02.02 (Motor rated frequency). After running, if the ramp frequency is equal to or greater than P91.10, current is detected and count starts. When P91.11 is reached, if the current is less than P91.12 (or P91.13 in reverse running), the current detection passes, the VFD increases the frequency to P91.09. If the current detection fails, the VFD remains the original frequency.</p> <p>Note: The light-load speed-boost target frequency setting must be higher than the set frequency. Otherwise, speed boost cannot be implemented although the conditions are met. If the set frequency is higher than P91.10, the original frequency is remained.</p> <p>P91.09 setting range: 0.00–100.00Hz P91.10 setting range: 50.0%–100.0% (of the motor rated frequency) P91.11 setting range: 0.0–10.000s P91.12, P91.13 setting range: 0.0–150.0%</p> <p>Note: Light load speed boost mode 1 is</p>	40.0 %	○

Function code	Name	Description	Default	Modify
		applicable to the open-loop mode.		
P91.14	Heavy-load speed-limit detection frequency		40.00Hz	<input type="radio"/>
P91.15	Heavy-load speed-limit detection delay	<p>When the set frequency is greater than the heavy load speed-limit detection frequency (P91.14), the motor running frequency becomes stable after reaching the detection frequency (P91.14), and load detection is performed after the time specified by P91.15. The load detection value is used for heavy load speed limit calculation. The load detection value P19.11 can be viewed through the keypad.</p> <p>P91.14 setting range: 0.00Hz–P02.02 P91.15 setting range: 0.00–5.00s P19.11 setting range: 0.0% –150.0% (of the motor rated torque)</p>	0.35s	<input type="radio"/>
P91.16	Electromotive power upper limit of constant-power speed boost/limit		90.0%	<input type="radio"/>
P91.17	Electricity generation power upper limit of constant-power speed boost/limit	<p>Constant power speed limit frequency = Power upper limit * Motor rated frequency/Load detection value</p> <p>The constant power mode is used for speed adjustment. The constant power speed limit frequency under the present load is calculated by using algorithms (using P91.16, P91.17, and P19.11 for reference).</p>	100.0%	<input type="radio"/>

Function code	Name	Description	Default	Modify
		<p>When P91.08=1, in constant power speed boost mode, if the constant power speed limit frequency is lower than or equal to the frequency upper limit P00.04, the VFD runs at the constant power speed limit frequency. At the same time, if the set frequency is higher than or equal to the constant power speed limit frequency, the speed is limited at constant power; if the set frequency is lower than the constant power speed limit frequency, the speed boosts.</p> <p>When P91.08=2, in constant power speed limit mode, if the constant power speed limit frequency is lower than or equal to the frequency upper limit P00.04: if the set frequency is higher than or equal to the constant power speed limit frequency, the speed is limited at constant power; if the set frequency is lower than the constant power speed limit frequency, the set frequency is used for running.</p> <p>For example, when P00.03=100Hz, P91.16=90.0%, and motor rated frequency=50.00Hz:</p> <p>If the detected load value during motor upward running is 30.0%, the limited frequency=150Hz(90.0%*50.00Hz/30.0%), the calculated limited frequency is higher than P00.03. If P91.08=1, the set frequency P00.03 is used for running. If P91.08=2, the constant power speed limit frequency does not work, and the set frequency is used for running.</p> <p>If the detected load value during motor upward running is 60.0%, the limited frequency =75Hz(90.0%*50.00Hz/60.0%), the heavy load speed limit function works. The upward max. output frequency is limited to 75Hz. If P91.08=1, the frequency 75Hz is used for running. If P91.08=2, the max. running frequency is 75Hz,</p>		

Function code	Name	Description	Default	Modify
		<p>and the set frequency is used for running.</p> <p>The similar calculation method is applicable to motor downward running, only replacing P91.16 with P91.17.</p> <p>Note: During open/closed loop switchover (there is difference in load detection value), adjust P91.16 and P91.17, and the heavy load speed limit frequency cannot be lower than the heavy load speed limit detection frequency P91.14. P91.16, P91.17 setting range: 30.0%–120.0% (of the motor rated power)</p>		
P91.18	Load limit T1 in stepped speed limit upward running	<p>When the stepped speed limit mode is used, the limit parameters for upward running and for downward running are set separately and can be adjusted according to the actual situation. When the detected load (open-loop output current or closed-loop output torque) exceeds the limited value, the running frequency must be lower than the set restricted frequency. For example, during motor upward running, when the detected load is greater than P91.18, the frequency is restricted to P91.19 (or when the set frequency is less than P91.19, the running frequency is the set frequency). When the detected load is greater than P91.20 (but less than P91.18), the frequency is restricted to P91.21.</p> <p>The detected load values in open/closed loop state have deviation. During the open/closed loop switchover process, the load limit value can</p>	70.0%	<input type="radio"/>
P91.19	Restricted frequency f1 in stepped speed limit upward running		50.00Hz	<input type="radio"/>
P91.20	Load limit T2 in stepped speed limit upward running		45.0%	<input type="radio"/>
P91.21	Restricted frequency f2 in stepped speed limit upward running		75.00Hz	<input type="radio"/>
P91.22	Load limit T3 in stepped speed limit upward running		25.0%	<input type="radio"/>
P91.23	Restricted frequency f3 in stepped speed limit upward running		100.00Hz	<input type="radio"/>

Function code	Name	Description	Default	Modify
P91.24	Load limit adjusted gain in stepped speed limit upward running	be adjusted through P91.24 . P91.24 is valid for P91.18 , P91.20 , and P91.22 . For example, when the same load is carried upward and tested, if P19.11 =50.0% in closed-loop state and P19.11 =55.0% in open-loop state, there is a difference of 5%. In the actual use, after setting closed-loop parameters, if you need to switch to the open-loop state, you only need to set P91.24 to 5.0% (0 in closed-loop state), and you do not need to modify P91.18 , P91.20 , or P91.22 .	0.0%	<input type="radio"/>
P91.25	Torque limit adjusted gain in stepped speed limit downward running	The situation of downward running is similar and therefore you only need to set parameters related to downward running.	0.0%	<input type="radio"/>
P91.26	Load limit T1 in stepped speed limit downward running	Note: The heavy load speed limit frequency cannot be lower than P91.14 . P91.18 , P91.20 , P91.22 , P91.26 , P91.28 , P91.30 setting range: 0.0%–150.0% (Open-loop output current is relative to the motor rated current, while closed-loop output torque is relative to the motor rated torque.)	55.0%	<input type="radio"/>
P91.27	Restricted frequency f1 in stepped speed limit downward running	P91.19 , P91.21 , P91.23 , P91.27 , P91.29 , P91.31 setting range: 0.00– P00.04	50.00Hz	<input type="radio"/>
P91.28	Load limit T2 in stepped speed limit downward running	P91.24 , P91.25 setting range: -20.0%–20.0% (Open-loop output current is relative to the motor rated current, while closed-loop output torque is relative to the motor rated torque.)	48.0%	<input type="radio"/>
P91.29	Restricted frequency f2 in stepped speed limit downward running		75.00Hz	<input type="radio"/>
P91.30	Load limit T3 in stepped speed limit downward running		25.0%	<input type="radio"/>
P91.31	Restricted frequency f3 in stepped speed limit downward running		100.00Hz	<input type="radio"/>

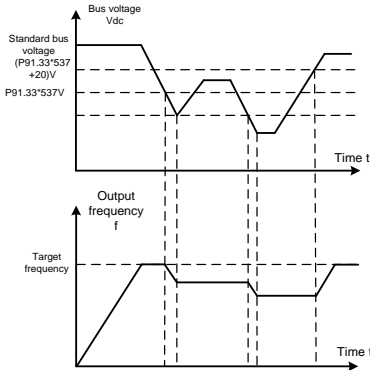
Function code	Name	Description	Default	Modify
P91.32	Enabling frequency decrease with voltage	Frequency decrease with voltage indicates that the VFD can automatically decrease the output frequency to maintain torque output in case of low line or bus voltage.	1	☉
P91.33	Starting voltage of frequency decrease with voltage	 <p>The following assumes that the target frequency is set as the rated frequency.</p> <p>When P91.32=1, if the bus voltage is less than the starting frequency (Standard bus voltage*P91.33), output frequency starts decrease, the regulated target frequency is (Rated frequency*Present bus voltage/Standard bus voltage); if the bus voltage increases but it does not reach the restoration voltage (Standard bus voltage*(P91.33+5%), the output frequency remains unchanged; if the bus voltage continuously decreases, the output frequency continuously decreases; if the bus voltage rises and becomes greater than the restoration voltage, the output frequency increases to the rated frequency.</p> <p>P91.32 setting range: 0: Disable 1: Enable</p> <p>P91.33 setting range: 70.0%–95.0% (Standard bus voltage 537V)</p>	85.0%	○
P91.34	DEC position limit	0–1	0	☉

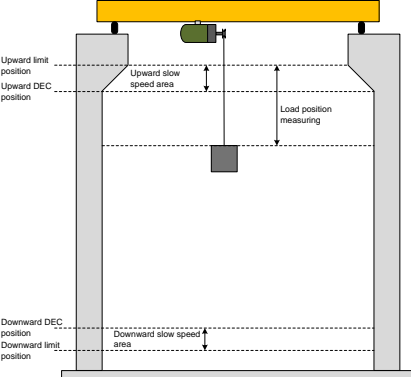
Function code	Name	Description	Default	Modify
	mode	<p>0: Single direction limit 1: Bi-directional limit</p>  <p>Single direction limit: When the upward DEC limit position is reached, the upward slow speed area is entered, the VFD runs at P91.35 and stops at sudden if the upward limit position is reached; the upward speed is restricted, but the downward speed is not restricted. Downward DEC position limit uses the similar rule.</p> <p>Bi-directional limit: When the upward/downward DEC limit position is reached, the upward/downward slow speed zone is entered, which indicates that both the upward and downward speeds are limited.</p> <p>(Terminal command mode)</p>		
P91.35	DEC position limit restricted frequency	0.00–20.00Hz	10.00Hz	○
P91.37	Enabling HDO based vortex control for tower crane slewing	<p>0–1 0: HDO keeps the same function as specified by P06.00 1: HDO is used as PWM signal for voltage adjustment output. P91.37=1: Enable the tower crane rotating vortex control. HDO connects to the PWM input of the turbulence module. You can enable the</p>	0	◎



Function code	Name	Description	Default	Modify
		output voltage of the turbulence module to change with the frequency by setting P91.38–P91.47.		
P91.38	Frequency f0	<p>P91.38 setting range: P91.40–P00.03 (Max. output frequency)</p> <p>P91.40 setting range: P91.42–P91.38</p> <p>P91.42 setting range: P91.44–P91.40</p> <p>P91.44 setting range: P91.46–P91.42</p> <p>P91.46 setting range: 0.00Hz–P91.44</p> <p>P91.39, P91.41, P91.43, and P91.47 setting range: 0.0%–100.0%</p> <p>Segmented adjustment is performed based on the cycle ratio and frequency.</p>	50.00Hz	<input type="radio"/>
P91.39	Duty ratio corresponding to frequency f0		100.0%	<input type="radio"/>
P91.40	Frequency f1		40.00Hz	<input type="radio"/>
P91.41	Duty ratio corresponding to frequency f1		80.0%	<input type="radio"/>
P91.42	Frequency f2		20.00Hz	<input type="radio"/>
P91.43	Duty ratio corresponding to frequency f2		40.0%	<input type="radio"/>
P91.44	Frequency f3		10.00Hz	<input type="radio"/>
P91.45	Duty ratio corresponding to frequency f3		20.0%	<input type="radio"/>
P91.46	Frequency f4		0.00Hz	<input type="radio"/>
P91.47	Duty ratio corresponding to frequency f4		Note: The HDO output polarity is specified by P06.05 .	0.0%
P91.48	HDO carrier frequency	0.5–10.0kHz	1.0kHz	<input type="radio"/>
P91.49	HDO closing delay during stop	0–100.0s	5.0s	<input type="radio"/>
P91.50	Pre torque input signal source	0–4 0: Invalid 1: AI1 2: AI2 3: Modbus 4: Internally given	0	<input type="radio"/>
P91.51	Pre torque offset	In closed-loop mode:	0.0%	<input type="radio"/>
P91.52	Drive-side gain	Setting pre torque is to output the torque	1.000	<input type="radio"/>
P91.53	Braking-side gain	corresponding to load weight in advance so as to reduce the start impact and prevent reserve	1.000	<input type="radio"/>

Function code	Name	Description	Default	Modify
		driving or slip during start. Setting P91.51 is to eliminate the impact of mechanical counterweight for lifting; pre torque compensation is directly performed if there is no mechanical counterweight. Pre torque compensation quantity = $K \cdot (P91.50 - P91.51)$, in which $K = P91.52$ when the motor is in electromotive state and $K = P91.53$ when the motor is in power generation (braking) state. P91.51 setting range: -100.0–100.0% P91.52, P91.53 setting range: 0.000–7.000		
P91.54	Pre torque direction	0–1 0: Forward 1: Reverse	0	<input type="radio"/>
P91.55	Enabling rope tracking	P91.55: 0–1	0	<input type="radio"/>
P91.56	Rope-tracking speed boost frequency	P91.56: 0.00–50.00HZ P91.57: 0.000–10.000s P91.58: 0.00–120.0% When the rope tracking function has been	25.00HZ	<input type="radio"/>
P91.57	Delay when rope-tracking frequency reached	enabled, if the set frequency is lower than the rope tracking frequency, the VFD boosts to the rope tracking frequency after startup and takes a delay later. When the delay is reached, the VFD	1.000s	<input type="radio"/>
P91.58	Rope-tracking torque	calculates the output torque. If the output frequency is greater than the preset torque (empty-load torque usually), the VFD considers the rope is too tight. Then the frequency is decreased to the set frequency.	40.0%	<input type="radio"/>

Function code	Name	Description	Default	Modify
		<p>Note: This function is mainly applicable to crane trolleys.</p>		

P92 group—Hoisting protection function group 3

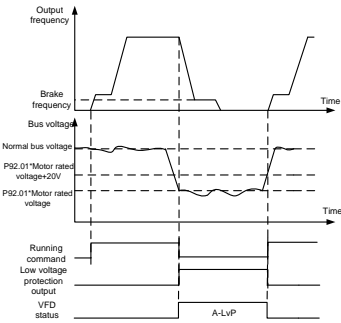
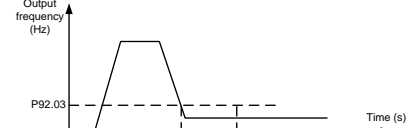
Function code	Name	Description	Default	Modify
P92.00	Selecting from low voltage protection, power-on brake detection, and 3PH input power loss detection	0x000–0x111 Ones place: Whether to enable low voltage protection 0: Disable 1: Enable Used together with P92.01 to perform low	0x000	☉
P92.01	Low voltage protection point	voltage protection. Tens place: Whether to enable power-on brake detection. 0: Disable 1: Enable Used together with P92.08–P92.11 to perform power-on brake detection in closed-loop vector mode. Hundreds place: Whether to enable 3PH input power loss detection. 0: Disable 1: Enable Used together with P92.47 to perform 3PH input	1.05	○

Function code	Name	Description	Default	Modify
		<p>power loss detection.</p>  <p>When P92.00=1, if the bus voltage is less than (P92.01*Motor rated voltage), low voltage protection is started, the VFD decelerates to stop.</p> <p>If the bus voltage restores to a value greater than (P92.01*Motor rated voltage + 20V), low voltage protection is automatically disabled.</p> <p>P92.00 setting range: 0: Disable 1: Enable P92.01 setting range: 1.00–1.30</p>		
P92.02	Low-speed run protection time	<p>Low-speed run protection is applied to devices to which long-time low speed running is not applicable, preventing overheating caused by late dissipation.</p> 	0.000s	☉
P92.03	Setting of low-speed run frequency	 <p>When P92.02 is a non-zero value, low-speed running protection is enabled, if the running frequency of the VFD is equal to or less than</p>	5.00Hz	○

Function code	Name	Description	Default	Modify
		<p>P92.03, and the last time is equal to or greater than P92.02, the VFD reports a low-speed running protection fault (LSP).</p> <p>P92.02 setting range: 0.000–50.000s</p> <p>P92.03 setting range: 0.00–20.00Hz</p>		
P92.04	Overload protection current detection value	When P92.38 =1 overload protection is enabled. When P92.04 >0, if the ramp frequency is equal to or greater than (P90.16 +2.00Hz) during upward running, the VFD starts checking the current (closed-loop torque current or open-closed output current). If the current is equal to or greater than P92.04 , the VFD reports the overload protection alarm after the detection time reaches P92.05 . This restriction is not applicable to downward running.	0.0%	⊙
P92.05	Overload detection time	<p>P92.04 setting range: 0.0–150.0% (relative to the motor rated torque in closed-loop state; relative to the motor rated current in open-loop state; 0 indicates disabling)</p> <p>P92.05 setting range: 0.0–5.0s</p>	0.5s	○
P92.06	Brake detection reminding interval	When P92.06 >0, the brake detection reminding function is enabled, if the accumulative running time of the VFD is equal to or greater than	0.0	⊙
P92.07	Brake detection reminding hold	P92.06 , the signal indicator is controlled through relay output signal or braking detection is	5	○

Function code	Name	Description	Default	Modify
	time	reminded through the buzzer. The reminding hold time is specified by P92.07 . After the time elapsed, reminding is not performed until re-power on. P92.06 setting range: 0.0–1000.0h P92.07 setting range: 0–100min		
P92.08	Brake detection torque setting	In open-loop control: Set a fixed torque and frequency and run the VFD. Through visual inspection, if the brake is not opened within the detection time, braking is normal. Otherwise, braking is abnormal. In closed-loop control mode, there are two startup situations: Situation 1: When the tens place of P92.00 is 1, brake detection is automatically performed after power-on. Situation 2: When the braking force detection terminal enabling signal is valid (terminal function 85 is selected), the VFD keeps the brake closed, if a running command is input, the VFD performs brake detection. The detection logic is as follows: The VFD runs with P92.08 at P92.09 and detects the encoder pulse count. If the detected encoder pulse count exceeds P92.11 within P92.10 , it is considered that braking force is insufficient and slip risk may exist. Then the multifunction output terminal outputs brake failure signal and the brake slip fault and outputs the brake failure fault (bE).	100.0%	<input type="radio"/>
P92.09	Brake detection frequency setting		2.00Hz	<input type="radio"/>
P92.10	Brake detection time setting		1.5s	<input type="radio"/>
P92.11	Brake detection judging pulse threshold (closed-loop)		1000	<input type="radio"/>

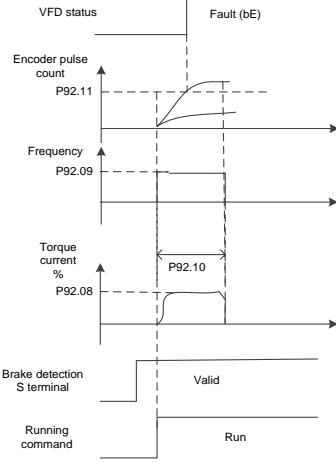
Function code	Name	Description	Default	Modify
		 <p> P92.08 setting range: 0.0% –180.0% (of the motor rated torque) P92.09 setting range: 0.00Hz–20.00Hz P92.10 setting range: 0.0s–30.0s P92.11 setting range: 0–20000 </p>		
P92.12	Enabling PT100/PT1000 temperature detection	0x00–0x11 Ones place: whether to enable PT100 temperature detection 0: Disable 1: Enable Tens place: whether to enable PT1000 temperature detection 0: Disable 1: Enable	0x00	Ⓢ
P92.13	Enabling PT100/PT1000 disconnection detection	0x00–0x11 Ones place: whether to enable PT100 disconnection detection 0: Disable 1: Enable Tens place: whether to enable PT1000 disconnection detection 0: Disable 1: Enable	0x00	Ⓢ

Function code	Name	Description	Default	Modify
P92.14	PT100 overtemperature protection point	0.0–150.0°C	120.0°C	○
P92.15	PT100 overtemperature pre-alarm point	0.0–150.0°C	100.0°C	○
P92.16	PT1000 overtemperature protection point	0.0–150.0°C	120.0°C	○
P92.17	PT1000 overtemperature pre-alarm point	0.0–150.0°C	100.0°C	○
P92.18	PT100/PT1000 calibrated temperature upper limit	50.0–150.0°C	120.0°C	○
P92.19	PT100/PT1000 calibrated temperature lower limit	-20.0–50.0°C	20.0°C	○
P92.20	Digital of PT100/PT1000 calibrated temperature	0–4 0: Normal detection 1: PT100 lower limit digital calibration autotuning 2: PT100 upper limit digital calibration autotuning 3: PT1000 lower limit digital calibration autotuning 4: PT1000 upper limit digital calibration autotuning After autotuning is completed, the function code is automatically cleared, and the calibration value is automatically saved to the I/O card.	0	○
P92.21	PTC overtemperature selection	0–1 0: The PTC function is enabled through terminal selection. When the PTC overtemperature alarm A-Ptc is reported, this cannot terminate normal running.	0	◎

Function code	Name	Description	Default	Modify
		1: The PTC function is enabled through terminal selection. When the PTC overtemperature fault PtcE is reported, this results in stop.		
P92.22	Type of sensor for AI to detect motor temperature	0-3 0: None 1: PT100 2: PT1000 3: KTY84 4: PTC (supporting only AI1)	0	○
P92.23	AI detected motor overtemperature protection threshold	0.0-200.0°C	110.0	○
P92.24	AI detected motor overtemperature pre-alarm threshold	0.0-200.0°C	90.0	○
P92.25	Input phase loss delay frequency at REV run	If the VFD runs in reverse direction, and the frequency is low than P92.25, the phase loss alarm is reported only when this situation lasts a time specified by P92.26. P92.25 setting range: 0.00-50.00Hz P92.26 setting range: 0.0-10.0s	30.00	○
P92.26	Input phase loss delay time at REV run		0	○
P92.27	Anti-snag protection braking torque	<p>Output frequency</p> <p>P92.28</p> <p>P92.29</p> <p>S-terminal anti-snag protection command</p> <p>Output torque</p> <p>P92.27</p>	0.0%	○
P92.28	Braking torque ACC/DEC time		0.200s	○
P92.29	Braking torque end frequency		Anti-snag indicates that the VFD outputs reserve torque so that the motor can stop at the fastest speed. A smaller value of P92.28 indicates a faster braking speed. When the motor decelerates to P92.29 , the VFD stops.	0.10Hz

Function code	Name	Description	Default	Modify
		<p>P92.27 setting range: 0.0–300.0% (of the motor rated current)</p> <p>P92.28 setting range: 0.000–10.000s</p> <p>P92.29 setting range: 0.00–30.00Hz</p>		
P92.30	Enabling set frequency protection	<p>0–1</p> <p>1: If Set frequency ≤ Brake closing frequency, the VFD reports A-rSF, and it closes the brake but does not stop.</p> <p>2: If Set frequency ≤ Brake closing frequency, the VFD reports A-rSF, and it closes the brake and stops.</p> <p>3: If Set frequency ≤ Brake closing frequency, the VFD reports SFE, and it closes the brake and stops.</p> <p>4: If Set frequency ≤ P92.31, the VFD reports SFE, and it closes the brake and stops.</p> <p>After the function is enabled, if the brake is opened, detection protection is performed.</p> <p>When the set frequency is equal to or lower than the brake frequency or the value of P92.31, the system decreases the speed to the brake frequency or P92.31, and then performs the action specified by P92.30. If the brake is closed, no detection is performed.</p>	0	⊙
P92.31	Set frequency fault protection threshold	0.00–10.00Hz	2.00Hz	⊙
P92.32	Current imbalance multiple	<p>0.0–5.5</p> <p>When the value is not zero, current imbalance detection is enabled. When the 3PH current max. value divided by the min. value is greater than this multiple, the Cuu fault is reported.</p>	0.0	⊙
P92.33	Enabling overspeed fault detection	<p>P92.33 setting range: 0–1</p> <p>P92.34 setting range: 100.0%–500.0% (of the set frequency)</p>	0	⊙
P92.34	Overspeed fault value	The overspeed protection function can be enabled in open/closed loop vector mode, but in closed loop mode, the actual speed feedback	150.0%	⊙

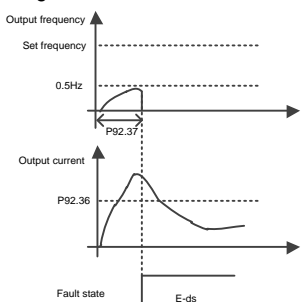
Function code	Name	Description	Default	Modify
		comes from the encoder. When the overspeed protection function is enabled, the overspeed protection threshold of VFD is calculated, which is Set frequency * Overspeed protection percentage. When the VFD runs, if the actual frequency is greater than or equal to the protection threshold, the VFD considers it is in the overspeed state, reports an overspeed fault, and stops running.		
P92.35	Enabling stalling fault detection	P92.35 setting range: 0–1	0	⊙
P92.36	Stalling detection current value	P92.36 setting range: 0.0 –250.0% (100.0% corresponding to the motor rated current) Setting range of P92.37: 0.00–10.00s	200.0%	⊙
P92.37	Stalling detection time	The stalling protection function can be enabled in open/closed loop vector mode, but in closed loop mode, the actual speed feedback comes from the encoder. When the stalling protection function is enabled, if the target frequency is greater than 0.50Hz during VFD running, the VFD starts delay timing. When the preset time is reached, if the actual running frequency is still lower than 0.50Hz, and the output current is greater than the stalling protection current value, which lasts 20ms, the VFD considers stalling occurs, and then it reports the fault and stops running. 	3.00s	⊙
P92.38	Enabling overload	0–2 0: Disable	0	○

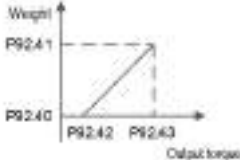
Function code	Name	Description	Default	Modify
		1: Torque overload Determined by P92.04 and P92.05. 2: Weight overload Determined by P92.39–P92.46.		
P92.39	Weighing calibration	Setting range of P92.39: 0–2 0: Normal mode	0	⊙
P92.40	Peeled loading	1: Peeled autotuning	0.00	○
P92.41	Non-empty loading	2: Loaded autotuning This parameter is automatically cleared after autotuning is completed.	0.00	○
P92.42	Peeled torque		0.0%	○
P92.43	Loaded torque	<p>P92.40 setting range: 0.0–20.00t P92.41 setting range: 0.0–20.00t P92.42 Setting range: 0–250.0% (of the motor rated torque) P92.43 Setting range: 0–250.0% (of the motor rated torque)</p> <p>For peeled autotuning, when P92.39=1, the LED keypad displays "LoAd1". After pressing "Run", the autotuning starts, and the obtained torque value is automatically saved to P92.42. In addition, the VFD decelerates to stop. When the VFD stops, the LED keypad does not display "LoAd1".</p> <p>For loaded autotuning, when you have entered the weight to P92.41 and set P92.39=2, the LED keypad displays "LoAd2". After pressing "Run", the autotuning starts, and the obtained torque value is automatically saved to P92.43. In addition, the VFD decelerates to stop. When the VFD stops, the LED keypad does not display "LoAd2".</p> 	0.0%	○
P92.44	Mechanism rated	0.0–20.00t	2.00	⊙

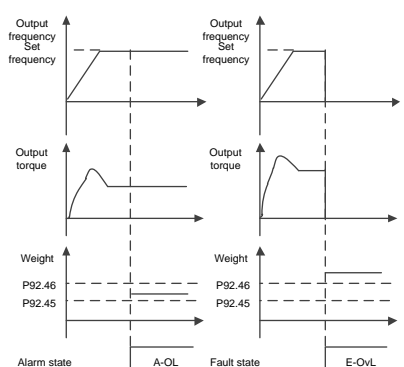
Function code	Name	Description	Default	Modify
	load	0–150.0% (of the mechanism rated load)		
P92.45	Mechanism overload pre-alarm point	0–150.0% (of the mechanism rated load) When the weighing function is enabled, if the VFD reaches the constant speed running state, the VFD output torque is obtained in real time, and then the present weight is calculated by using the torque and weight line simulated by weight autotuning. The weight is displayed through P94.37. If the present weight is greater than the protection point, the overweight fault is reported, and the VFD stops. If the present weight is less than the protection point but greater than the pre-alarm point, the overweight alarm is reported, but the VFD still runs.	90.0%	☉
P92.46	Mechanism overload protection point	When the weighing function is enabled, the VFD displays the weight in real time during constant speed running; the VFD displays zero during ACC/DEC or stop. 	105.0%	☉

P93 group—Closed-loop hoisting functions

Function code	Name	Description	Default	Modify
P93.00	Brake slip speed threshold	0.10–5.00Hz	1.00Hz	○
P93.01	Brake slip fault	0.000–5.000s	0.500s	○

Function code	Name	Description	Default	Modify
	delay	The value 0 indicates brake slip is not detected, while a non-zero value indicates brake slip is detected. If the feedback frequency is greater than the value of P93.00, which lasts the time specified by P93.01, the brake failure fault (bE) is reported. For details, see the torque verifying and brake slip descriptions in the brake function commissioning section.		
P93.02	Zero servo protection mode	0-3 0: Disable zero servo 1: Zero servo input slows down 2: Zero servo input is always valid (keep running at zero speed) 3: Zero servo input slows down with a zero-speed running period specified by P93.38 Note: 1. At certain faults that cannot be reset, such as VFD internal hardware damaged, zero servo cannot be entered. At the faults that can be reset, with zero servo conditions met, zero servo can be entered. 2. Every time zero servo is exited, torque verification is not performed only at the first running command giving, which means the verification is performed at all the following running command giving. 3. When P93.02=2, the motor becomes hot, the fan cannot be mounted at the same shaft as the motor, and it must be independently controlled.	0	○
P93.03	Brake failure protection frequency	• When P93.02 =1: The zero servo function needs to be used in closed-loop vector control. During stop, the VFD	4.00Hz	○
P93.04	Slow lowering hold time	checks whether the pulse value is greater than P93.05 . If yes, the VFD reports the brake failure	2.0s	○
P93.05	Zero servo tolerance pulse	alarm, and the output can be set through the relay. After the brake failure alarm protection	20000	○

Function code	Name	Description	Default	Modify
	threshold	input delay specified by P93.06 (if the pulse value is greater than triple the zero servo tolerance pulse threshold specified by P93.05 within the period, the delay specified by P93.06 is skipped), if P93.02=1 (Zero servo input slows down), the VFD runs downward slowly at the frequency specified by P93.03 , and it coasts to stop when the slow lowering hold time specified by P93.04 is reached. Then the VFD performs detection again and repeats the preceding steps, which are cyclical. • P93.02 =2 Zero servo protection mode Zero servo input is always valid (keep running at zero speed). P93.03 setting range: P90.17 (Reverse brake release frequency)–8.00Hz P93.04 setting range: 0.0s–30.0s P93.05 setting range: 0–60000		
P93.06	Brake failure alarm protection input delay	0–20.000s	0.500s	○
P93.07	Brake failure alarm protection reset method	0–2 0: Only for downward running 1: Both for upward and downward running 2: Only for reset commands	0	◎
P93.08	Enabling height measuring	0–1 0: Disable 1: Enable internal measuring (motor encoder) 2: Enable external measuring (HDI) Note: When P93.08 =2, P20.15 =0 indicates HDI measuring the height.	0	◎
P93.09	Mechanical transmission ratio	For internal measurement (motor encoder), the encoder is mounted on the motor shaft, and P93.09 is the reduction ratio between the motor shaft and drum shaft. For external measurement (HDI), P93.09 is the reduction ratio between the encoder mounting shaft and pulley shaft. If the encoder is mounted	10.00	○

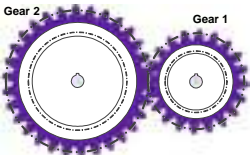
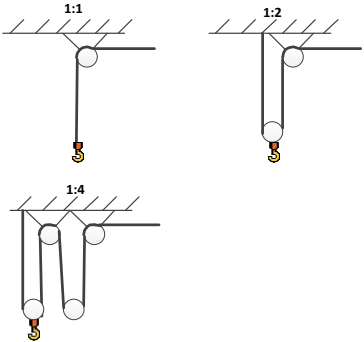
Function code	Name	Description	Default	Modify
		<p>on the pulley, set P93.09=1. For example, for gear speed reduction, Mechanical transmission ratio = (Number of teeth in gear 2)/(Number of teeth in gear 1)</p>  <p>Setting range: 0.01–300.00</p>		
P93.10	Suspension ratio	<p>Setting range: 1–4 1: 1:1 2: 1:2 3: Reserved 4: 1:4 For example: Suspension ratio</p>  <p>Note: The suspension ratio is related to the pulley through which the steel rope goes.</p>	1	⊙
P93.11	Rope length compensation	Rope length to compensate the distance from the center of gravity of the weight to the hook. 0.00m–50.00m	0.00m	○
P93.12	Cable diameter	To measure heights correctly in closed-loop mode, the actual running distance of the motor is calculated by using the encoder pulse count.	10.0	○
P93.13	Per-layer turns of drum winding		30	○
P93.14	Initial turns of drum winding	Before first running, the upward limit position must be calibrated.	0	○

Function code	Name	Description	Default	Modify
P93.15	Initial diameter of drum/pulley diameter	<p>The procedure for first running is as follows: Set the upward limit position terminal, for example, P05.05=64. Then the HDI terminal functions as the upward limit position input. If internal measurement (motor encoder) is enabled, set P93.08=1. Start the tower crane to run upward and stop at the upward limit position. Record the values of P93.14 (Initial turns of drum winding) and P93.15 (Initial diameter of drum/pulley diameter). In open/closed loop mode, if external measurement (HDI) is enabled, set P93.08=2. Start the tower crane to run upward and stop at the upward limit position. P93.12 setting range: 0.1–100.0mm P93.13 setting range: 1–200 P93.14 setting range: 0–P93.13 (Per-layer turns of drum winding) P93.15 setting range: 100.0–2000.0mm (Max. drum diameter in upward limit, including cable thickness) P19.15 setting range: 0.00–655.35m (hook lowering distance) P19.16, P19.17 setting range: 0–65535</p>	600.0	⊙
P93.16	Enabling upward/downward limit position check	<p>0x00–0x11 Ones place: 0: The upward limit position is not reached. 1: The upward limit position is reached. Tens place: 0: The downward limit position is not reached. 1: The downward limit position is reached. For example, when the upward/downward limit position needs to be set manually, you can enable the check of whether the upward/downward limit position is reached. When the hook reaches a certain distance from the top, the upward limit position is reached,</p>	0x00	○

Function code	Name	Description	Default	Modify
		P19.15 =0 (droop height); when the hook reaches a certain distance from the ground, P93.18 =0 (distance from downward limit position); P93.17 displays the distance between the upward and downward limit positions. During normal running between the upward and downward limit positions, P93.18 displays the downward limit position distance, while P19.15 displays the upward limit position distance; if the mechanism runs below the downward limit position, P93.18 displays a negative value.		
P93.17	Total height measured	0.00–655.35m (Total height measured from the upward limit position to the downward limit position)	0.00m	●
P93.18	Measured height 1	-50.00m–655.35m (The downward limit position is used as the reference point. During downward limit, P93.18 =0.00m)	0.00m	●
P93.19	Loose rope autotuning	0: Disable 1: Autotuning for upward 2: Autotuning for downward	0	◎
P93.20	Enabling loose rope protection	0–2 0: Disable 1: Enable 2: Enable stable lifting protection	0	◎
P93.21	Loose rope detection method	0–2 0: Set through torque 1: Set through torque autotuning 2: Set through external signal detection (AI1)	0	◎
P93.22	Upward set value of external loose rope signal	0.0–10.0V	0.0V	○
P93.23	Downward set value of external loose rope signal	0.0–10.0V	0.0V	○
P93.24	Torque setting for upward loose rope	After loose rope protection is enabled, loose rope detection is performed during crane	5.0%	○

Function code	Name	Description	Default	Modify
	protection	startup:		
P93.25	Torque setting for downward loose rope protection	When the hoist runs upward and reaches P93.26 , torque detection is performed after the delay P93.28 . If the detected status is non loose rope (Torque value > Loose rope torque P93.24 or P93.25 for downward running), normal ACC/DEC is performed.	5.0%	<input type="radio"/>
P93.26	Loose rope protection hold frequency	If the detected status is loose rope (Torque value <= Loose rope torque P93.24), the output frequency is restricted to P93.26 within P93.27 .	15.00Hz	<input type="radio"/>
P93.27	Loose rope protection hold time	If load holding, (Torque value) > (Loose rope torque P93.24 +2%), is detected within P93.27 , normal ACC/DEC is performed from this time. If the time exceeds P93.27 , normal ACC/DEC is performed from this time.	2.0s	<input type="radio"/>
P93.28	Loose rope detection delay	P93.24 can be set with the reference to the autotuning result P93.33 . Generally, the value of P93.24 can be the value of P93.33 added by 1%–2%.	0.5s	<input type="radio"/>

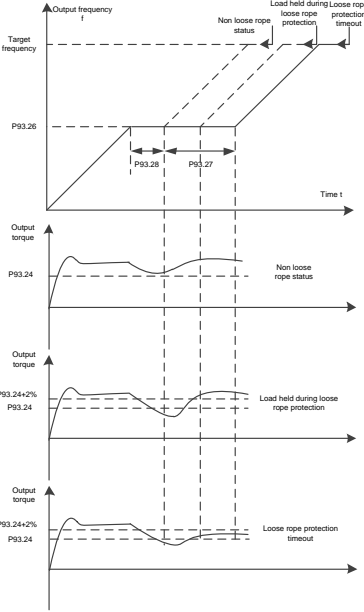
Function code	Name	Description	Default	Modify
		 <p>P93.24, P93.25 setting range: 0.0–50.0%(of the rated torque) P93.26 setting range: 10.00Hz–P02.02 P93.27 setting range: 0.0–50.0s P93.28 setting range: 0.0–5.0s</p>		
P93.29	Downward loose rope protection mode	P93.29 setting range: 0–1	0	☉
P93.30	REV running time of downward loose rope mode 2	During downward running, if the loose rope status occurs after the loose rope detection delay, the preset processing way is used. 0: Mode 1. The VFD reports the loose rope protection fault (SLE) and stops.	5.00s	○
P93.31	Frequency setting of downward loose rope mode 2		5.00Hz	○

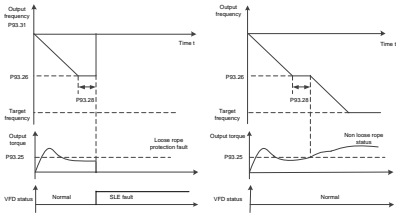
Function code	Name	Description	Default	Modify
		 <p>1: Mode 2. The VFD outputs the loose rope protection alarm (A-SL), changes the direction, and runs upward at the frequency specified by P93.31, and the VFD runs downward only when the time specified by P93.30 is reached or the loose rope status disappears.</p> <p>P93.30 setting range: 0–20.00s P93.31 setting range: 1.00Hz–10.00Hz Note: P93.30 must be greater than the sum of the time taken to decelerate from P93.26 to 0Hz and the time taken to accelerate from 0Hz to P93.31.</p>		
P93.32	Torque of upward loose rope autotuning	The autotuning procedure is as follows: Step 1 Put the hook on the ground and loosen the rope.	0.0%	○
P93.33	Torque of downward loose rope autotuning	Step 2 Set P93.19 =1 (or P93.19 for downward running). Step 3 Push the operating lever to step-2 speed (higher than 10Hz), which is held at least 1s in the loose rope state after the frequency is stable (to autotune stable frequency torque). Step 4 Stop the device and check the autotuning result. If P93.32 (or P93.33 for downward	0.0%	○

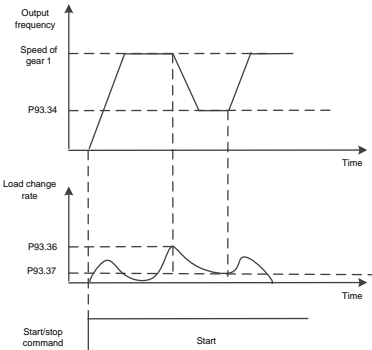
Function code	Name	Description	Default	Modify
		running) is not 0, autotuning is successful. Otherwise, you have to perform autotuning again. P93.32 , P93.33 setting range: 0.0–50.0%(of the rated torque from the autotuning result)		
P93.34	Smooth lifting protection frequency	When P93.20 =2, indicating stable lifting protection is enabled to attenuate the shock caused by violent jittering up and down when the	10.00Hz	<input type="radio"/>
P93.35	Smooth lifting torque change rate protection point 1 (in ACC)	load is lifted and by sudden changes in load during high-speed running. During constant speed running, if the detected torque change rate is greater than the smooth	40.0%/s	<input type="radio"/>
P93.36	Smooth lifting torque change rate protection point 2 (in constant speed running)	lifting torque change rate protection point 2 (specified by P93.36), the smooth lifting function is enabled, and the smooth lifting function set frequency (P93.34) is used. At this time, if the detected torque change rate is less than the smooth lifting torque change rate protection	40.0%/s	<input type="radio"/>
P93.37	Smooth lifting torque change rate protection point 3 (exiting smooth lifting)	point 3 (specified by P93.37), acceleration to the set frequency is executed, at gear-1 speed, as shown in the preceding figure.  <p>Smooth lifting during constant speed running During ACC running, if the detected torque change rate is greater than the smooth lifting torque change rate protection point 1 (specified by P93.35), the smooth start function is enabled.</p>	10.0%/s	<input type="radio"/>

Function code	Name	Description	Default	Modify
		<p>and the smooth start function set frequency (P93.34) is used. At this time, if the detected torque change rate is less than the smooth lifting torque change rate protection point 3 (specified by P93.37), acceleration to the set frequency is executed, at gear-2 speed, as shown in the preceding figure.</p> <p>Smooth lifting during ACC running P93.34 setting range: 5.00Hz–50.00Hz P93.35 setting range: 0.0–150.0%/s P93.36 setting range: 0.0–150.0%/s P93.37 setting range: 0.0–150.0%/s Note: The smooth lifting function is applicable only to the upward running.</p>		
P93.38	Zero-servo zero-speed hold time	Valid only when P93.02=3, indicating the hold time of zero speed running, in minutes.	10	☉
P93.39	ACC/DEC delay detection time in smooth lifting	0.0–20.0s	0.8	○

P94 group—Hoisting status display

Function code	Name	Description	Default	Modify
P94.00	Alarm display value	0–15 0: None 1: Input phase loss alarm (A- SPI)	0	●

Function code	Name	Description	Default	Modify
		2: Upward position limit alarm (A-LU) 3: Downward position limit alarm (A-Ld) 4: Low voltage protection alarm (A-LvP) 5: Overload protection alarm (A-OL) 6: Brake failure alarm (A-bS) 7: Brake feedback alarm (A-FA) 8: Loose rope protection alarm (A-SL) 9: PT100 overtemperature alarm (A-Ot1) 10: PT1000 overtemperature alarm (A-Ot2) 11: PT100 disconnection alarm (A-Pt1) 12: PT1000 disconnection alarm (A-Pt2) 13: PTC overtemperature alarm (A-Ptc) 14: AI detected overtemperature alarm (A-AOt) 15: Weighing alarm (A-OvL) 16: Alarm of slave brake feedback in master/slave control (A-SLO) 17: Alarm of automatic brake detection at power-on (A-bEt) 18: Alarm indicating the set frequency is less than the brake closing frequency after brake release (A-rSF)		
P94.01	Detected load torque value	0.0% –150.0% (of the motor rated torque)	0.0%	●
P94.02	Brake detection reminding time	0.0–1000.0h	0.0	●
P94.03	Actual step of graded multi-step speed	0–6	0	●
P94.04	Zero-point position status	0–2 0: There is input at zero-point position, but the VFD is still in running state. 1: The VFD has stopped, but there is input of zero-point signal, and zero position delay is reached (zero position is valid). 2: In condition of status 1, if a run command is given and the zero position has been left, the run command is valid.	0	●
P94.05	Measured height	0.00–655.35m (hook lowering distance)	0.00	●

Function code	Name	Description	Default	Modify
		(As the master in master/slave control, it sends this value.)		
P94.06	Hight bits of measured height count value	0-65535	0	●
P94.07	Low bits of measured height count value	0-65535	0	●
P94.08	PT100 calibrated temperature upper limit	-20.0-150.0°C	0.0	●
P94.09	PT100 calibrated temperature lower limit	-20.0-150.0°C	0.0	●
P94.10	Digital of PT100 calibrated temperature upper limit	0-4096	0	●
P94.11	Digital of PT100 calibrated temperature lower limit	0-4096	0	●
P94.12	PT1000 calibrated temperature upper limit	-20.0-150.0°C	0.0	●
P94.13	PT1000 calibrated temperature lower limit	-20.0-150.0°C	0.0	●
P94.14	Digital of PT1000 calibrated temperature upper limit	0-4096	0	●
P94.15	Digital of PT1000 calibrated temperature lower limit	0-4096	0	●
P94.16	PT100 present	-50.0-150.0°C	0.0°C	●

Function code	Name	Description	Default	Modify
	temperature			
P94.17	PT100 present digital	0–4096	0	●
P94.18	PT1000 present temperature	-50.0–150.0°C	0.0°C	●
P94.19	PT1000 present digital	0–4096	0	●
P94.20	AI detected motor temperature	-20.0–200.0°C	0.0°C	●
P94.21	Brake slip speed	0.00Hz–10.00Hz	0.00Hz	●
P94.22	Brake slip pulses	0–65535	0	●
P94.23	Light load speed boost status	0–3 0: Normal mode 1: Forward speed boost with light load 2: Reverse speed boost with light load 3: Constant power speed boost	0	●
P94.24	Status of frequency decrease with voltage	0–1 0: Normal mode 1: In state of frequency decrease with voltage	0	●
P94.25	Average torque of loose rope	0.0% –150.0% (of the motor rated torque)	0.0%	●
P94.26	Load torque change rate in smooth lifting	0.0–100.0%/s	0.0%	●
P94.27	Status of smooth lifting	0–1 0: Normal mode 1: In smooth lifting	0	●
P94.28	Current imbalance multiple	0.0–6553.5	0.0	●
P94.31	Anti-sway status	0–1 0: No anti-sway 1: In anti-sway state 2: In sway reducing state	0	●
P94.32	Obtained rope length	0–600.0m (As the slave in master/slave control, it receives this value.)	0	●
P94.33	Rope length with compensation	0–600.0m	0	●

Function code	Name	Description	Default	Modify
P94.34	Pendulum length cycle	0–60000ms	0	●
P94.35	Real-time ACC/DEC time	0–60000ms	0	●
P94.36	Present ACC speed	-300.00–300.00Hz/ms	0	●
P94.37	Mechanism real-time load	0.0–20.00t	0	●
P94.38	Max. slip per-unit display	0–65535	0	●
P94.39	Present application macro	0–18	0	●

8 Troubleshooting

8.1 What this chapter contains

The chapter tells you how to reset faults and check faults history. A complete list of alarms and fault information as well as possible causes and corrective measures are presented in this chapter.



⚡ Only trained and qualified professionals are allowed to carry out the operations mentioned in this chapter. Please carry out operations according to instructions presented in "Safety precautions".

8.2 Indications of alarms and faults

Faults are indicated by indicators. When the **TRIP** indicator is on, the alarm or fault code displayed on the keypad indicates the VFD is in abnormal state. This chapter covers most of the alarms and faults, and their possible causes and corrective measures. If you cannot find out the causes of alarms or faults, contact local INVT office.

8.3 Fault reset

The VFD can be reset by pressing the keypad key **STOP/RST**, digital inputs, or by cutting off the VFD power. After faults are removed, the motor can be started again.

8.4 Fault history

The function codes from P07.27 to P07.32 record the types of the last six faults. The function codes P07.33–P07.40, P07.41–P07.48, P07.49–P07.56 record the running data of the VFD at the last three faults.

8.5 Faults and alarms

Do as follows if the VFD encounters a fault:

1. Check whether there is any exception on the keypad. If yes, contact the local INVT office.
2. If no, check function group P07 to view the fault record parameters and understand the actual condition.
3. See the following table for a detailed solution and check for exceptions.
4. Rectify the fault or ask for help.
5. Ensure the fault has been rectified, perform fault reset, and run the VFD again.

8.5.1 Faults and solutions

Note: The numbers enclosed in square brackets such as [1], [2] and [3] in the **Fault type** column in the following table indicate the VFD fault type codes read through communication.

Fault code	Fault type	Possible cause	Solution
OUt1	[1] Inverter unit U-phase	ACC is too fast. IGBT module is damaged.	Increase ACC time. Replace the power unit.

Fault code	Fault type	Possible cause	Solution
OUt2	protection [2] Inverter unit V-phase protection	Misoperation caused by interference. Drive wires are poorly connected.	Check drive wires. Check whether there is strong interference surrounding the peripheral device.
OUt3	[3] Inverter unit W-phase protection	To-ground short circuit occurs.	
OV1	[7] Overvoltage during acceleration	Exception occurred to input voltage. Large energy feedback.	Check the input power. Check whether load DEC time is too short. or the motor starts during rotating. Install dynamic brake components. Check the related function code settings.
OV2	[8] Overvoltage during deceleration	Lack of braking units. Energy-consumption braking is not enabled.	
OV3	[9] Overvoltage during constant speed running	Deceleration time is too short.	
OC1	[4] Overcurrent during acceleration	ACC/DEC is too fast. The voltage of the grid is too low.	Increase ACC/DEC time. Check the input power. Select a VFD with larger power.
OC2	[5] Overcurrent during deceleration	The VFD power is too small. Load transient or exception occurred.	
OC3	[6] Overcurrent during constant speed running	To-ground short circuit or output phase loss occurred. Strong external interference sources. Overcurrent stalling protection is not enabled.	rotation is not smooth. Check the output wiring. Check whether there is strong interference. Check the related function code settings.
UV	[10] Bus undervoltage fault	The voltage of the grid is too low. Overvoltage stall protection is not enabled.	Check the grid input power. Check the related function code settings.
OL1	[11] Motor overload	Grid voltage too low. The motor rated current is set incorrectly. Motor stall or load jumps violently.	Check the grid voltage. Reset the rated current of the motor. Check the load and adjust torque boost.

Fault code	Fault type	Possible cause	Solution
OL2	[12] VFD overload	ACC is too fast. The motor in rotating is restarted. Grid voltage too low. Load too large. Power is too small.	Increase ACC time. Avoid restart after stop. Check the grid voltage. Select the VFD with larger power. Select proper motor.
SPI	[13] Input phase loss	Phase loss or violent fluctuation occurred on inputs R, S, and T.	Check the input power. Check the installation wiring.
SPO	[14] Phase loss on output side	Phase loss occurred to U, V, W output (or the three phases of motor is asymmetrical).	Check the output wiring. Check the motor and cable.
OH1	[15] Rectifier module overheating	Air duct is blocked or fan is damaged. Ambient temperature is too high. Long-time overload running.	Ventilate the air duct or replace the fan. Lower the ambient temperature.
OH2	[16] Inverter module overheat Fault		
EF	[17] External fault	SI external fault input terminal acts.	Check external device input.
CE	[18] RS485 communication fault	Baud rate set improperly. Communication line fault. Incorrect communication address. Communication suffers from strong interference.	Set a proper baud rate. Check the wiring of communication interfaces. Set the communication address correctly. Replace or change the wiring to enhance the anti-interference capacity.
ItE	[19] Current detection fault	Poor contact of the connector of control board. Hall component damaged. Exception occurred to amplification circuit.	Check the connector and re-plug. Replace the hall component. Replace the main control board.
tE	[20] Motor autotuning fault	Motor capacity does not match with the VFD capacity. This fault may occur if the capacity difference exceeds five power classes.	Change the VFD model, or adopt V/F mode for control; Set proper motor type and nameplate parameters; Empty the motor load and carry

Fault code	Fault type	Possible cause	Solution
		Motor parameter is set improperly; The parameters gained from autotuning deviate sharply from the standard parameters. Autotuning timeout.	out autotuning again. Check the motor wiring and parameter setup; Check whether the upper limit frequency is larger than 2/3 of the rated frequency.
EEP	[21] EEPROM operation fault	Control parameter reading/writing error. EEPROM damaged.	Press STOP/RST to reset. Replace the main control board.
PIDE	[22] PID feedback offline fault	PID feedback offline. PID feedback source disappears.	Check PID feedback signal wires. Check PID feedback source.
bCE	[23] Braking unit/resistor fault	Braking circuit fault or braking pipe damage. Small resistance of the external braking resistor. Braking resistor short circuited or PB-to-PE short circuited.	Check the braking unit, and replace with a new braking pipe. Increase the braking resistance. Check the braking resistor wiring.
END	[24] Running time reached	Actual VFD running time longer than internally set running time.	Ask the supplier to adjust the preset running time.
OL3	[25] Electronic overload fault	The VFD reports overload pre-alarm according to the setting.	Check the load and overload pre-alarm threshold
PCE	[26] Keypad communication fault	Keypad cable connected improperly or disconnected. Keypad cable too long, causing strong interference. Keypad or mainboard communication circuit error.	Check the keypad cable to determine whether a fault occurs. Check for and remove the external interference source. Replace the hardware and seek maintenance services.
UPE	[27] Parameter upload error	Keypad cable connected improperly or disconnected. Keypad cable too long, causing strong interference. Keypad or mainboard communication circuit error.	Check for and remove the external interference source. Replace the hardware and seek maintenance services. Replace the hardware and seek maintenance services.
DNE	[28] Parameter download error	Keypad cable connected improperly or disconnected.	Check for and remove the external interference source.

Fault code	Fault type	Possible cause	Solution
		Keypad cable too long, causing strong interference. Keypad data storage error	Replace the hardware and seek maintenance services. Re-back up the data on the keypad.
ETH1	[32] To-ground short-circuit fault 1	VFD output is short connected to the ground. Current detection circuit is faulty. Actual motor power setup deviates sharply from the VFD power.	Check whether the motor wiring is normal. Replace the hall component. Replace the main control board; Reset the motor parameters properly.
ETH2	[33] To-ground short-circuit fault 2	VFD output is short connected to the ground. Current detection circuit is faulty. Actual motor power setup deviates sharply from the VFD power.	Check whether the motor wiring is normal. Replace the hall component. Replace the main control board; Reset the motor parameters properly.
dEu	[34] Speed deviation fault	The load is too heavy or stalled.	Check the load to ensure it is proper, and increase the detection time; Check whether the control parameters are set properly.
STo	[35] Mal-adjustment fault	SM control parameters are set incorrectly. Autotuned parameters are not accurate. The VFD is not connected to the motor.	Check the load and ensure the load is normal. Check whether control parameters are set correctly. Increase the maladjustment detection time.
LL	[36] Electronic underload fault	The VFD reports underload pre-alarm according to the setting.	Check the load and overload pre-alarm threshold.
ENC1o	[37] Encoder offline fault	Encoder line sequence is wrong, or signal wires are poorly connected.	Check the encoder wiring.
ENC1d	[38] Encoder reversal fault	The encoder speed signal is contrary to the motor running	Reset encoder direction.

Fault code	Fault type	Possible cause	Solution
		direction.	
ENC1Z	[39] Encoder Z pulse offline fault	Z signal wires are disconnected.	Check the wiring of Z signal.
OT	[59] Motor overtemperature fault	Motor overtemperature input terminal is valid. The temperature detection resistance is abnormal. Long-time overload running or exception occurred.	Check the wiring of the motor overtemperature input terminal (terminal function 57). Check whether the temperature sensor is proper; Check the motor, and perform maintenance on the motor.
STO	[40] Safe torque off	Safe torque off function is enabled by external forces.	/
STL1	[41] Exception occurred to safe circuit of channel 1	The wiring of STO is improper; Fault occurred to external switch of STO; Hardware fault occurred to safety circuit of channel 1	Check whether terminal wiring of STO is proper and firm enough; Check whether the external switch of STO can work properly; Replace the control board.
STL2	[42] Exception occurred to safe circuit of channel 2	The wiring of STO is improper; Fault occurred to external switch of STO; Hardware fault occurred to safety circuit of channel 2	Check whether terminal wiring of STO is proper and firm enough; Check whether the external switch of STO can work properly; Replace the control board.
STL3	[43] Exception occurred to channel 1 and channel 2	Hardware fault occurred to STO circuit.	Replace the control board.
CrCE	[44] Safety code FLASH CRC check fault	Control board is faulty.	Replace the control board.
E-Err	[55] Repetitive expansion card type	The two inserted expansion cards are of the same type	You should not insert two cards with the same type. Check the type of expansion card, and remove one card after power-off.
ENCUV	[56] Encoder UVW loss fault	No electric level variation occurred to UVW signal	Check the wiring of UVW; Encoder is damaged.
F1-Er	[60] Failed to identify the	There is data transmission in interfaces of card slot 1,	Confirm whether the expansion card inserted can be supported;

Fault code	Fault type	Possible cause	Solution
	expansion card in card slot 1	however, it cannot read the card type.	Stabilize the expansion card interfaces after power-off, and check whether the fault persists at next power-on. Check whether the insertion port is damaged. If yes, replace the insertion port after power-off.
F2-Er	[61] Failed to identify the expansion card in card slot 2	There is data transmission in interfaces of card slot 2, however, it cannot read the card type.	Confirm whether the expansion card inserted can be supported; Stabilize the expansion card interfaces after power-off, and check whether the fault persists at next power-on. Check whether the insertion port is damaged. If yes, replace the insertion port after power-off.
F3-Er	[62] Failed to identify the expansion card in card slot 3	There is data transmission in interfaces of card slot 3, however, it cannot read the card type.	Confirm whether the expansion card inserted can be supported; Stabilize the expansion card interfaces after power-off, and check whether the fault persists at next power-on. Check whether the insertion port is damaged. If yes, replace the insertion port after power-off.
C1-Er	[63] Communication timeout of expansion card at card slot 1	There is no data transmission in interface at card slot 1.	Confirm whether the expansion card inserted can be supported; Stabilize the expansion card interfaces after power-off, and check whether the fault persists at next power-on. Check whether the insertion port is damaged. If yes, replace the insertion port after power-off.
C2-Er	[64] Communication timeout of expansion card at	There is no data transmission in interface at card slot 2.	Confirm whether the expansion card inserted can be supported; Stabilize the expansion card interfaces after power-off, and

Fault code	Fault type	Possible cause	Solution
	card slot 2		check whether the fault persists at next power-on. Check whether the insertion port is damaged. If yes, replace the insertion port after power-off.
C3-Er	[65] Communication timeout of expansion card at card slot 3	There is no data transmission in interface at card slot 3.	Confirm whether the expansion card inserted can be supported; Stabilize the expansion card interfaces after power-off, and check whether the fault persists at next power-on. Check whether the insertion port is damaged. If yes, replace the insertion port after power-off.
E-DP	[29] PROFIBUS card communication timeout fault	There is no data transmission between the communication card and the upper computer (or PLC).	Check whether the communication card wiring is loose or dropped.
E-NET	[30] Ethernet card communication timeout fault	There is no data transmission between the communication card and the upper computer.	Check whether the communication card wiring is loose or dropped.
E-CAN	[31] CANopen card communication timeout fault	There is no data transmission between the communication card and the upper computer (or PLC).	Check whether the communication card wiring is loose or dropped.
E-PN	[57] PROFINET card communication timeout fault	There is no data transmission between the communication card and the upper computer (or PLC).	Check whether the communication card wiring is loose or dropped.
E-CAT	[66] EtherCAT card communication timeout fault	There is no data transmission between the communication card and the upper computer (or PLC).	Check whether the communication card wiring is loose or dropped.
E-BAC	[67] BACNet card communication timeout fault	There is no data transmission between the communication card and the upper computer (or PLC).	Check whether the communication card wiring is loose or dropped.

Fault code	Fault type	Possible cause	Solution
E-DEV	[68] DeviceNet card communication timeout fault	There is no data transmission between the communication card and the upper computer (or PLC).	Check whether the communication card wiring is loose or dropped.
SECAN	[58] CAN master/slave card communication timeout fault	There is no data transmission between the CAN master and slave communication cards.	Check whether the communication card wiring is loose or dropped.
S-Err	[69] Master/slave synchronous CAN slave fault	Fault occurred to one of the CAN slave VFDs.	Detect the CAN slave VFD and analyze the corresponding fault cause.
dIS	[70] VFD disabled	The input terminal selects VFD enabling, but the terminal signal is invalid.	Check the input terminal setting and terminal signal.
tbE	[71] Contactor feedback fault	The contactor feedback circuit is disconnected or in poor contact. The contactor feedback detection time is too short.	Check the contactor feedback circuit. Increase the detection time P91.05 to a proper value.
FAE	[72] Brake feedback fault	The brake feedback circuit is disconnected or in poor contact. The brake feedback detection time is too short.	Check the brake feedback circuit. Increase the detection time P90.32 to a proper value.
tPF	[73] Torque verification fault	The torque verification current, moment force setting, and torque verification fault detection time are set improperly.	Set the torque verification current, moment force setting, and torque verification fault detection time P90.30 properly. Check whether the motor rated power is set correctly.
StC	[74] Operating lever zero-position fault	The operating lever does not return to the zero position. The operating lever zero-position signal is adhered.	Put the operating lever to the zero position. Check out the operating lever zero-position signal.
LSP	[75] Low-speed run protection fault	Running speed too low.	Check whether the running speed is continuously lower than P92.03 .
tCE	[76] Terminal	The terminal gives both the	Check the input terminal signal.

Fault code	Fault type	Possible cause	Solution
	command exception	upward and downward commands at the same time.	
POE	[77] Power on Terminal command exception	The terminal command is detected at power-on.	Check whether P01.18 is set to enable the VFD reports a fault when a terminal command is valid at power-on. Check the input terminal signal.
SLE	[78] Loose rope protection fault	The hook rope is abnormal. The downward loose rope parameter setting is improper.	Check whether the hook rope is normal. Check whether the downward loose rope detection torque is proper.
bE	[79] Brake failure	The brake force is insufficient. The brake detection parameter setting is improper.	Check whether the brake is normal. Check whether the brake slip parameter setting is proper.
ELS	[80] Master/slave position synchronization fault	The encoder pulse difference between the master and slave is too great. The pulse threshold setting is improper.	Check the encoders for the master and slave. Check whether the pulse threshold of the slave is too small.
AdE	[81] Analog speed reference deviation fault	If the speed is given by analog, the analog voltage is greater than 1.0V after zero-position detection is complete.	Check the analog wiring and current voltage value.
OtE1	[82] PT100 overtemperature fault	The current environment temperature is too high. PT100 detection circuit is abnormal. PT100 overtemperature protection setting is improper.	Check the current environment temperature. Check PT100 circuit. Check whether PT100 overtemperature protection point is too small.
OtE2	[83] PT1000 overtemperature fault	The current environment temperature is too high. PT1000 detection circuit is abnormal. PT1000 overtemperature protection setting is improper.	Check the current environment temperature. Check PT1000 circuit. Check whether PT1000 overtemperature protection point is too small.

Fault code	Fault type	Possible cause	Solution
SFE	[84] Set frequency fault	The set frequency is too small.	Check whether the frequency reference is smaller than the set frequency protection point.
Cuu	[85] Current imbalance	Three-phase output current imbalance.	Check the load wiring with UVW. Check whether the value of P92.32 is too small.
PtcE	[86] PTC overtemperature fault	The current environment temperature is too high.	Check the current environment temperature.
E-OvL	[87] Overload fault	Load too heavy.	Check whether load is too heavy. Check whether P92.46 (Mechanism overload protection point) is too small.
E-OS	[88] Overspeed fault	Motor overspeed.	Check whether P92.34 is too small.
E-dS	[89] Stalling fault	Motor suffers stalling.	Check whether the brake can be opened properly. Check whether P92.36 is too small.
E-216	[90] 216 communication disconnection	No data communicates between the communication card and upper computer (or PLC).	Check whether the communication card wiring is loose or disconnected.
216EF	[91] External fault received by 216 communication card	The 216 communication card received an external fault.	Remove the external fault.
E-AI1	[92] AI1 disconnected	AI1 disconnected.	Check AI1 wiring.
E-AI2	[93] AI2 disconnected	AI2 disconnected.	Check AI2 wiring.
E-AI3	[94] AI3 disconnected	AI3 disconnected.	Check AI3 wiring.
E-EIP	[95] EtherNet IP communication timeout	No data communicates between the communication card and upper computer (or PLC).	Check whether the communication card wiring is loose or disconnected.

Fault code	Fault type	Possible cause	Solution
E-PAO	[96] No upgrade bootloader	The burned file does not contain a bootloader.	Burn the file with a bootloader again. You can screen out this fault by setting P14.12. (Bootloader inexistence does not affect the normal running of machine.)

8.5.2 Alarms and solutions

Note: The numbers enclosed in square brackets such as [1], [2] and [3] in the **Alarm type** column in the following table indicate the VFD alarm type codes read through communication.

Alarm code	Alarm type	Possible cause	Solution
A-SPI	[1] Input phase loss alarm	During stop, a loss of either input phase R, S, or T occurs or fluctuation is great.	Check the input power source and wiring.
A-LU	[2] Upward position limit alarm	The input terminal has set the upward limited position reaching function, and there is a signal reference to the terminal.	Check whether the allowed highest position point has been reached. Check the input terminal signal.
A-Ld	[3] Downward position limit alarm)	The input terminal has set the downward limited position reaching function, and there is a signal reference to the terminal.	Check whether the allowed lowest position point has been reached. Check the input terminal signal.
A-LvP	[4] Low voltage alarm	The bus voltage is too low.	Check whether the voltage protection point is too high. Check whether the grid voltage or rectifier module is abnormal.
A-OL	[5] Overload protection alarm	The load is too heavy. The overload protection parameter is set is improperly.	Check whether the load is too heavy. Check whether the overload protection point is too small.
A-bS	[6] Brake failure alarm	The brake force is insufficient. The encoder is abnormal. The zero servo detection parameter is set is	Check whether the brake works normally. Check whether the encoder works normally. Check whether the zero servo

Alarm code	Alarm type	Possible cause	Solution
		improperly.	tolerance pulse threshold is too small.
A-FA	[7] Brake feedback alarm	The brake feedback circuit is disconnected or in poor contact. The brake feedback detection time is too short.	Check the brake feedback circuit. Increase the detection time P90.32 to a proper value.
A-SL	[8] Loose rope protection alarm	The hook rope is abnormal. The downward loose rope parameter setting is improper.	Check whether the hook rope is normal. Check whether the downward loose rope detection torque is proper.
A-Ot1	[9] PT100 overtemperature alarm	The current environment temperature is too high. PT100 overtemperature protection setting is improper.	Check the current environment temperature. Check whether PT100 overtemperature protection point is too small.
A-Ot2	[10] PT1000 overtemperature alarm	The current environment temperature is too high. PT1000 overtemperature alarm setting is improper.	Check the current environment temperature. Check whether PT1000 overtemperature protection point is too small.
A-Pt1	[11] PT100 disconnection alarm	PT100 connection circuit is opened.	Check PT100 connection circuit.
A-Pt2	[12] PT1000 disconnection alarm	PT1000 connection circuit is opened.	Check PT1000 connection circuit.
A-Ptc	[13] PTC overtemperature alarm	The actual environment temperature is too high.	Check the current environment temperature.
A-AOt	[14] AI detected overtemperature alarm	The actual environment temperature is too high. Abnormal temperature sensor detection line. Improper overtemperature protection setting.	Check the temperature sensor wiring. Check whether P92.24 is too small.
A-OvL	[15] Weighing alarm	Motor overloaded.	P92.04 Overload protection current detection value

Alarm code	Alarm type	Possible cause	Solution
A-SLO	[16] Alarm of slave brake feedback in master/slave control	The brake release of the slave is not synchronous with that of the master.	Check parameter settings.
A-bEt	[17] Reminding in power-on auto brake detection	Automatic brake detection is performed after power-on	Check the tens place setting of P92.00.
A-rSF	[18] Set frequency lower than brake closing frequency	The set frequency is lower than the brake closing frequency after the brake is released in the situation where brake control is enabled.	Check the setting of P92.30 to check whether the set frequency is lower than the brake closing frequency.

Note: After fault recovery, the corresponding alarm is automatically reset.

8.5.3 Other status

Displayed code	Status type	Possible cause	Solution
PoFF	System power failure	The system is powered off or the bus voltage is too low.	Check the grid conditions.

8.6 Analysis on common faults

8.6.1 Motor fails to work

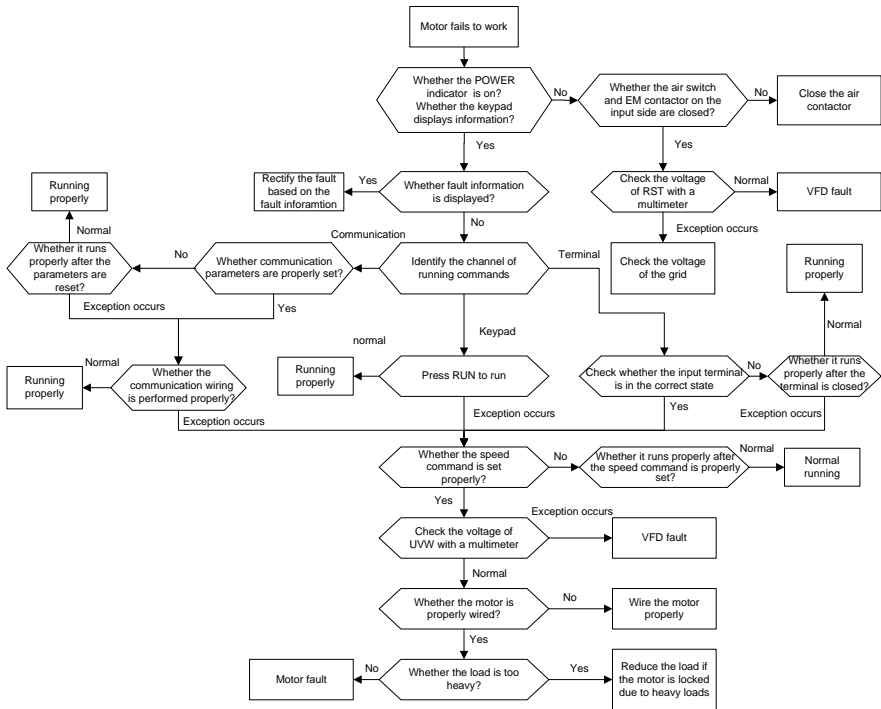

8.6.2 Motor vibrates

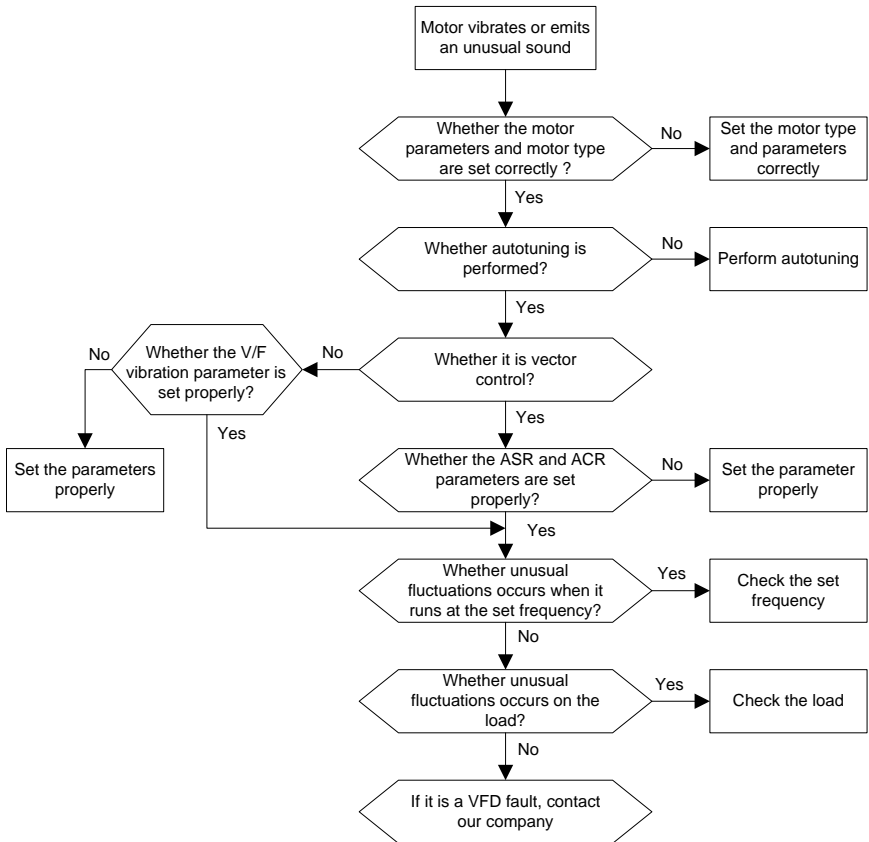

8.6.3 Overvoltage

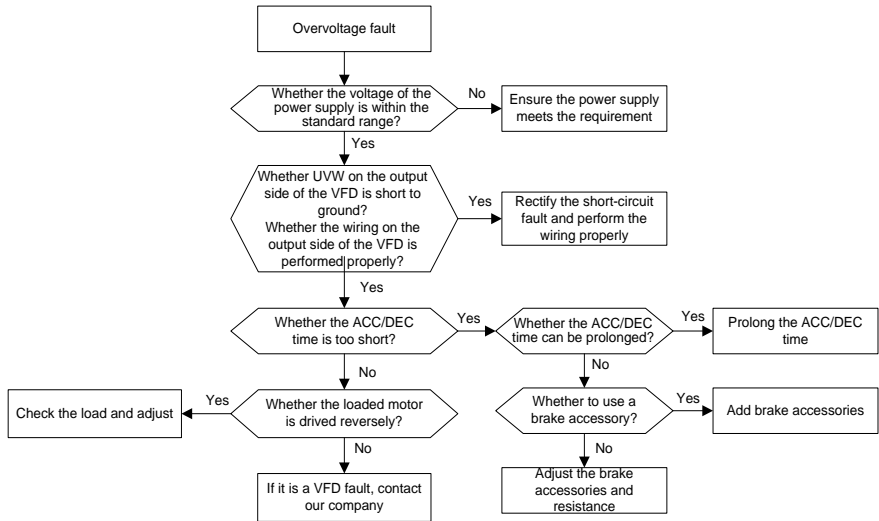

8.6.4 Undervoltage

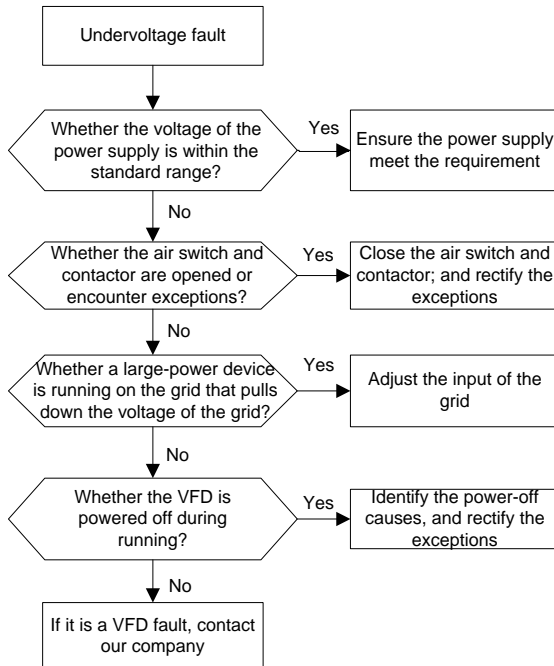

8.6.5 Motor overheating

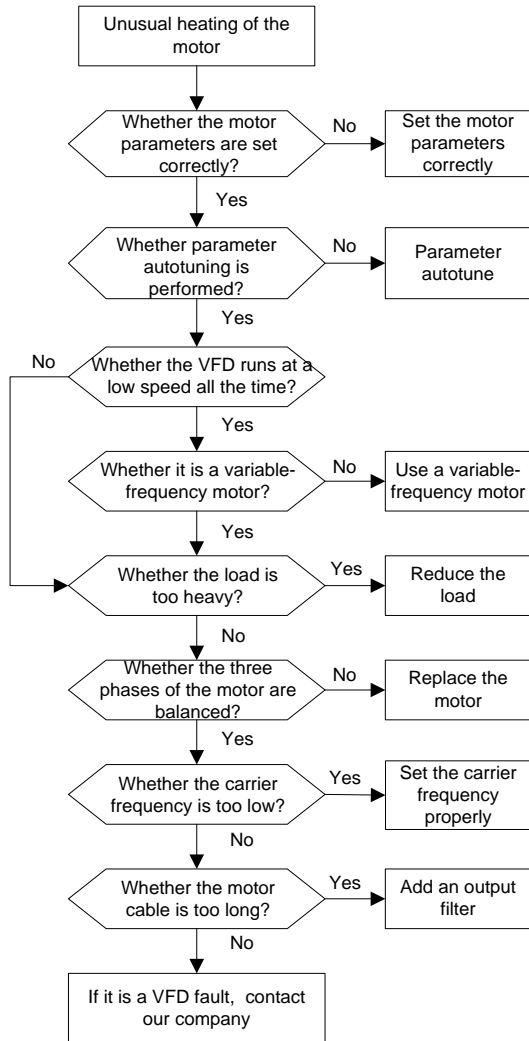

8.6.6 VFD overheating

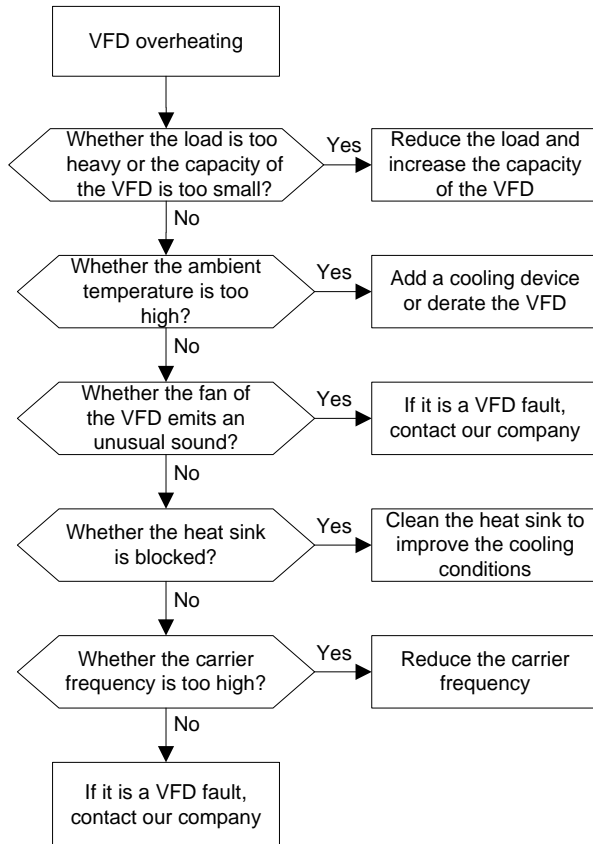

8.6.7 Motor stalls during ACC

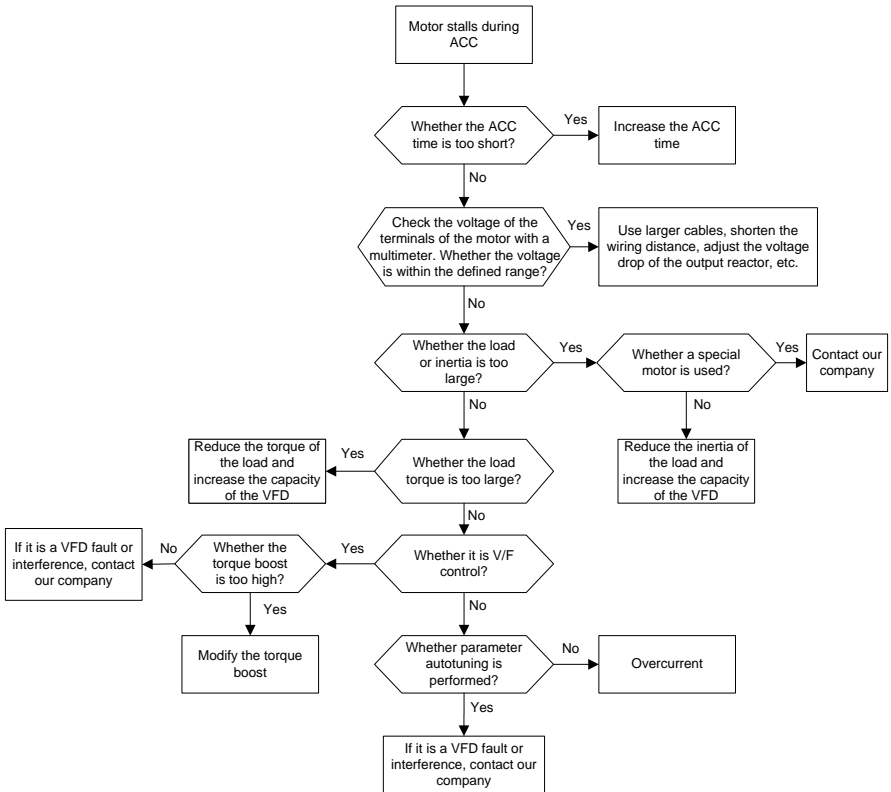

8.6.8 Overcurrent

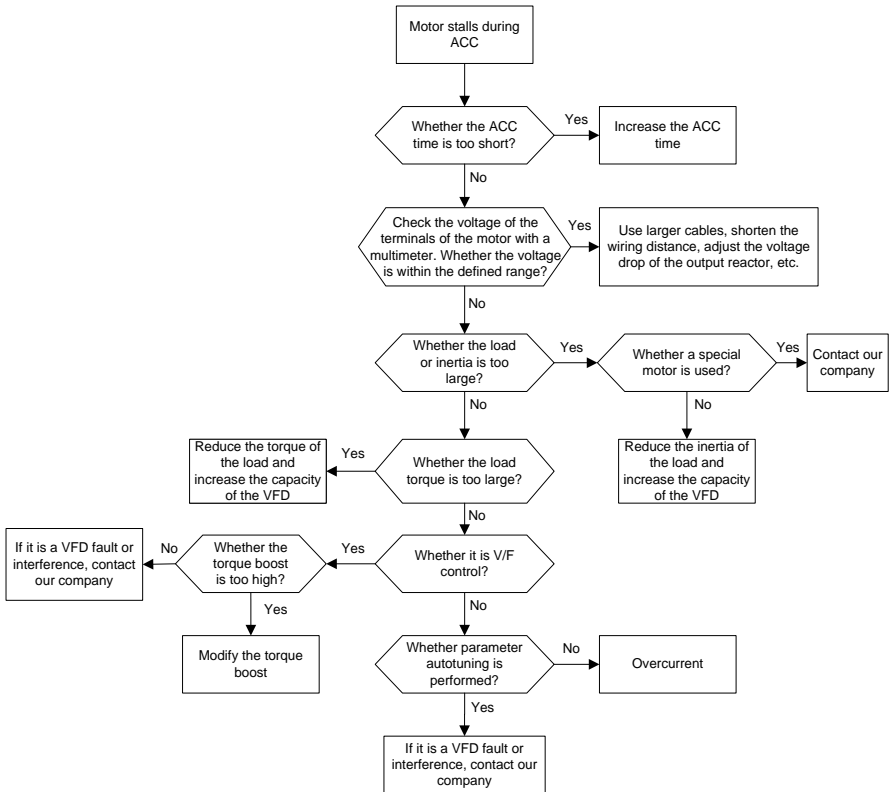

8.7 Countermeasures on common interference

8.7.1 Interference on meter switches and sensors

Interference phenomenon

Pressure, temperature, displacement, and other signals of a sensor are collected and displayed by a human-machine interaction device. The values are incorrectly displayed as follows after the VFD is started:

1. The upper or lower limit is wrongly displayed, for example, 999 or -999.
2. The display of values jumps (usually occurring on pressure transmitters).
3. The display of values is stable, but there is a large deviation, for example, the temperature is dozens of degrees higher than the common temperature (usually occurring on thermocouples).
4. A signal collected by a sensor is not displayed but functions as a drive system running feedback signal. For example, the VFD is expected to decelerate when the upper pressure limit of the

compressor is reached, but in actual running, it starts to decelerate before the upper pressure limit is reached.

5. After the VFD is started, the display of all kinds of meters (such as frequency meter and current meter) that are connected to the analog output (AO) terminal of the VFD is severely affected, displaying the values incorrectly.
6. Proximity switches are used in the system. After the VFD is started, the indicator of a proximity switch flickers, and the output level flips.

Solution

1. Check and ensure that the feedback cable of the sensor is 20 cm or farther away from the motor cable.
2. Check and ensure that the ground wire of the motor is connected to the PE terminal of the VFD (if the ground wire of the motor has been connected to the ground block, you need to use a multimeter to measure and ensure that the resistance between the ground block and PE terminal is lower than 1.5 Ω).
3. Try to add a safety capacitor of 0.1 μ F to the signal end of the feedback signal terminal of the sensor.
4. Try to add a safety capacitor of 0.1 μ F to the power end of the sensor meter (pay attention to the voltage of the power supply and the voltage endurance of the capacitor).
5. For interference on meters connected to the AO terminal of a VFD, if AO uses current signals of 0 to 20 mA, add a capacitor of 0.47 μ F between the AO and GND terminals; and if AO uses voltage signals of 0 to 10 V, add a capacitor of 0.1 μ F between the AO and GND terminals.

Note:

- When a decoupling capacitor is required, add it to the terminal of the device connected to the sensor. For example, if a thermocouple is to transmit signals of 0 to 20 mA to a temperature meter, the capacitor needs to be added on the terminal of the temperature meter.; if an electronic ruler is to transmit signals of 0 to 30 V to a PLC signal terminal, the capacitor needs to be added on the terminal of the PLC.
- If a large number of meters or sensors are disturbed. It is recommended that you configure an external C2 filter on the input power end of the VFD. For models of filters, see D.8 Filters.

8.7.2 Interference on RS485 communication

The interference described in this section on RS485 communication mainly includes communication delay, out of synchronization, occasional power-off, or complete power-off that occurs after the VFD is started.

If the communication cannot be implemented properly, regardless of whether the VFD is running, the exception is not necessarily caused by interference. You can find out the causes as follows:

1. Check whether the 485 communication bus is disconnected or in poor contact.

2. Check whether the two ends of line A or B are connected reversely.
3. Check whether the communication protocol (such as the baud rate, data bits, and check bit) of the VFD is consistent with that of the upper computer.

If you are sure that communication exceptions are caused by interference, you can resolve the problem through the following measures:

1. Perform simple inspection.
2. Arrange the communication cables and motor cables in different cable trays.
3. In multi-VFD application scenarios, adopt the chrysanthemum connection mode to connect the communication cables between VFDs, which can improve the anti-interference capability.
4. In multi-VFD application scenarios, check and ensure that the driving capacity of the master is sufficient.
5. In the connection of multiple VFDs, you need to configure one 120 Ω terminal resistor on each end.

Solution

1. Check and ensure that the ground wire of the motor is connected to the PE terminal of the VFD (if the ground wire of the motor has been connected to the ground block, you need to use a multimeter to measure and ensure that the resistance between the ground block and PE terminal is lower than 1.5 Ω).
2. Do not connect the VFD and motor to the same ground terminal as the upper computer (PLC, HMI, and touch screen). It is recommended that you connect the VFD and motor to the power ground, and connect the upper computer separately to a ground stud.
3. Try to short the signal reference ground terminal (GND) of the VFD with that of the upper computer controller to ensure that ground potential of the communication chip on the control board of the VFD is consistent with that of the communication chip of the upper computer.
4. Try to short GND of the VFD to its ground terminal (PE).
5. Try to add a safety capacitor of 0.1 μF on the power terminal of the upper computer (PLC, HMI, and touch screen). During this process, pay attention to the voltage of the power supply and the voltage endurance capability of the capacitor. Alternatively, you can use a magnet ring (Fe-based nanocrystalline magnet rings are recommended). Put the power L/N line or +/- line of the upper computer through the magnet ring in the same direction and wind 8 coils around the magnet ring.

8.7.3 Failure to stop and indicator shimmering due to motor cable coupling

Interference phenomenon

1. Failure to stop

In a VFD system where an S terminal is used to control the start and stop, the motor cable and control cable are arranged in the same cable tray. After the system is started properly, the S terminal cannot

be used to stop the inverter.

2. Indicator shimmering

After the VFD is started, the relay indicator, power distribution box indicator, PLC indicator, and indication buzzer shimmer, blink, or emit unusual sounds unexpectedly.

Solution

1. Check and ensure that the exception signal cable is arranged 20 cm or farther away from the motor cable.
2. Add a safety capacitor of 0.1 μF between the digital input terminal (S) and the COM terminal.
3. Connect the digital input terminal (S) that controls the start and stop to other idle digital input terminals in parallel. For example, if S1 is used to control the start and stop and S4 is idle, you can try to short connect S1 to S4 in parallel.

Note: If the controller (such as PLC) in the system controls more than 5 VFDs at the same time through digital input terminals (S), this scheme is not applicable.

8.7.4 Leakage current and interference on RCD

VFDs output high-frequency PWM voltage to drive motors. In this process, the distributed capacitance between the internal IGBT of a VFD and the heat sink and that between the stator and rotor of a motor may inevitably cause the VFD to generate high-frequency leakage current to the ground. A residual current operated protective device (RCD) is used to detect the power-frequency leakage current when a grounding fault occurs on a circuit. The application of a VFD may cause misoperation of a RCD.

1. Rules for selecting RCDs

- (1) VFD systems are special. In these systems, it is required that the rated residual current of common RCDs at all levels is larger than 200 mA, and the VFDs are grounded reliably.
- (2) For RCDs, the time limit of an action needs to be longer than that of a next action, and the time difference between two actions need to be longer than 20 ms. For example, 1s, 0.5s, and 0.2s.
- (3) For circuits in VFD systems, electromagnetic RCDs are recommended. Electromagnetic RCDs have strong anti-interference capability, and thus can prevent the impact of high-frequency leakage current.

Electronic RCD	Electromagnetic RCD
Low cost, high sensitivity, small in volume, susceptible to voltage fluctuation of the grid and ambient temperature, and weak anti-interference capability	Requiring highly sensitive, accurate, and stable zero-phase sequence current transformer, using permalloy high-permeability materials, complex process, high cost, not susceptible to voltage fluctuation of the power supply and ambient temperature, strong anti- interference capability

2. Solution to RCD misoperation (handling the VFD)

- (1) Try to remove the jumper cap at "EMC/J10" on the middle casing of the VFD.
 - (2) Try to reduce the carrier frequency to 1.5 kHz (P00.14=1.5).
 - (3) Try to modify the modulation mode to "3PH modulation and 2PH modulation" (P08.40=0).
3. Solution to RCD misoperation (handling the system power distribution)
- (1) Check and ensure that the power cable is not soaking in water.
 - (2) Check and ensure that the cables are not damaged or spliced.
 - (3) Check and ensure that no secondary grounding is performed on the neutral wire.
 - (4) Check and ensure that the main power cable terminal is in good contact with the air switch or contactor (all screws are tightened).
 - (5) Check 1PH powered devices, and ensure that no earth lines are used as neutral wires by these devices.
 - (6) Do not use shielded cables as VFD power cables and motor cables.

8.7.5 Live device chassis

Phenomenon

After a VFD is started, there is sensible voltage on the chassis, and you may feel an electric shock when touching the chassis. The chassis, however, is not live (or the voltage is far lower than the human safety voltage) when the VFD is powered on but not running.

Solution

1. If there is power distribution grounding or ground stud on the site, ground the cabinet chassis of the drive system through the power ground or stud.
2. If there is no grounding on the site, you need to connect the motor chassis to the ground terminal PE of the VFD, and ensure that the jumper at "EMC/J10" on the middle casing of the VFD is shorted.

9 Maintenance

9.1 What this chapter contains

This chapter describes how to carry out preventive maintenance on the VFD.

9.2 Periodical inspection

Little maintenance is required when the VFD is installed in an environment that meets requirements.

The following table describes the routine maintenance periods recommended by INVT.

Check scope		Item	Method	Criterion
Ambient environment		Check the temperature, and humidity, and whether there is vibration, dust, gas, oil spray, and water droplets in the environment.	Visual inspection, and use instruments for measurement.	The requirements stated in this manual are met.
		Check whether there are foreign matters, such as tools, or dangerous substances placed nearby.	Visual inspection	There are no tools or dangerous substances placed nearby.
Voltage		Check the voltage of the main circuit and control circuit.	Use multimeters or other instruments for measurement.	The requirements stated in this manual are met.
Keypad		Check the display of information.	Visual inspection	The characters are displayed properly.
		Check whether characters are not completely displayed.	Visual inspection	The requirements stated in this manual are met.
Main circuit	Common	Check whether the bolts loose or come off.	Screw them up.	No exception occurs.
		Check whether the machine is deformed, cracked, or damaged, or their color changes due to overheating and aging.	Visual inspection	No exception occurs.
		Check whether there are stains and dust attached.	Visual inspection	No exception occurs. Note: Discoloration of copper bars does not mean that they cannot work

Check scope	Item	Method	Criterion
			properly.
Conductor and wire	Check whether conductors are deformed or color change for overheat.	Visual inspection	No exception occurs.
	Check whether the wire sheaths are cracked or their color changes.	Visual inspection	No exception occurs.
Terminal block	Check whether there is damage.	Visual inspection	No exception occurs.
Filter capacitor	Check whether there is electrolyte leakage, discoloration, cracks, and chassis expansion.	Visual inspection	No exception occurs.
	Check whether the safety valves are released.	Determine the service life based on the maintenance information, or measure them through electrostatic capacity.	No exception occurs.
	Check whether the electrostatic capacity is measured as required.	Use instruments to measure the capacity.	Electrostatic capacity \geq initial value x 0.85
Resistor	Check whether there is displacement caused due to overheat.	Olfactory and visual inspection	No exception occurs.
	Check whether the resistors are disconnected.	Visual inspection, or remove one end of the connection cable and use a multimeter for measurement.	Resistance range: $\pm 10\%$ (of the standard resistance)
Transformer and reactor	Check whether there is unusual vibration sounds or smells.	Auditory, olfactory, and visual inspection	No exception occurs.

Check scope		Item	Method	Criterion
	EM contactor and relay	Check whether there are vibration sounds in the workshop.	Auditory inspection	No exception occurs.
		Check whether the contacts are in good contact.	Visual inspection	No exception occurs.
Control circuit	Control PCB and connector	Check whether the screws and connectors loose.	Screw them up.	No exception occurs.
		Check whether there is unusual smell or discoloration.	Olfactory and visual inspection	No exception occurs.
		Check whether there are cracks, damage, deformation, or rust.	Visual inspection	No exception occurs.
		Check whether there is electrolyte leakage or deformation.	Visual inspection, and determine the service life based on the maintenance information.	No exception occurs.
Cooling system	Cooling fan	Check whether there are unusual sounds or vibration.	Auditory and visual inspection, and turn the fan blades with your hand.	The rotation is smooth.
		Check whether the bolts loose.	Screw them up.	No exception occurs.
		Check whether there is decoloration caused due to overheat.	Visual inspection, and determine the service life based on the maintenance information.	No exception occurs.
	Ventilation duct	Check whether there are foreign matters blocking or attached to the cooling fan, air inlets, or air outlets.	Visual inspection	No exception occurs.

For more details about maintenance, contact the local INVT office, or visit our website www.invt.com, and choose **Support > Services**.

9.3 Cooling fan

The service life of the cooling fan of the VFD is more than 25,000 hours. The actual service life of the cooling fan is related to the use of the VFD and the temperature in the ambient environment.

You can view the running duration of the VFD through P07.14 (Accumulated running time).

The increase of the bearing noise indicates a fan fault. If the VFD is applied in a key position, replace the fan once the fan starts to generate unusual noise. You can purchase spares of fans from INVT.

Cooling fan replacement:



✧ Read Safety precautions carefully and follow the instructions to perform operations. Ignoring these safety precautions may lead to physical injury or death, or device damage.

1. Stop the VFD, disconnect the AC power supply, and wait for a time no shorter than the waiting time designated on the VFD.
2. Open the cable clamp to loose the fan cable (for the 380V 1.5–30 kW VFD models, the middle casing needs to be removed).
3. Disconnect the fan cable.
4. Remove the fan with a screwdriver.
5. Install a new fan in the VFD in the reverse steps. Assemble the VFD. Ensure that the air direction of the fan is consistent with that of the VFD, as shown in the following figure.

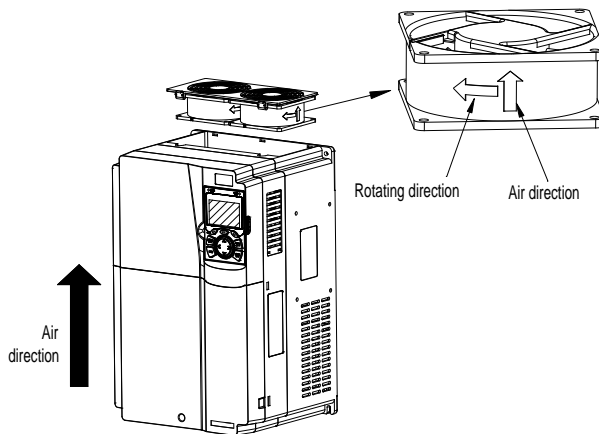

Figure 9-1 Fan maintenance for 7.5 kW and higher

6. Power on the VFD.

9.4 Capacitor

9.4.1 Capacitor reforming

If the VFD has been left unused for a long time, you need to follow the instructions to reform the DC bus capacitor before using it. The storage time is calculated from the date the VFD is delivered.

Storage time	Operation principle
Less than 1 year	No charging operation is required.
1 to 2 years	The VFD needs to be powered on for 1 hour before the first running command.
2 to 3 years	Use a voltage controlled power supply to charge the VFD: Charge the VFD at 25% of the rated voltage for 30 minutes and then charge it at 50% of the rated voltage for 30 minutes at 75% for another 30 minutes and finally charge it at 100% of the rated voltage for 30 minutes.
More than 3 years	Use a voltage controlled power supply to charge the VFD: Charge the VFD at 25% of the rated voltage for 2 hours, and then charge it at 50% of the rated voltage for 2 hours, at 75% for another 2 hours, and finally charge it at 100% of the rated voltage for 2 hours.

The method for using a voltage controlled power supply to charge the VFD is described as follows:

The selection of a voltage controlled power supply depends on the power supply of the VFD. For VFDs with an incoming voltage of 1PH/3PH 230 V AC, you can use a 230 V AC/2 A voltage regulator. Both 1PH and 3PH VFDs can be charged with a 1PH voltage controlled power supply (connect L+ to R, and N to S or T). All the DC bus capacitors share one rectifier, and therefore they are all charged.

For VFDs of a high voltage class, ensure that the voltage requirement (for example, 380 V) is met during charging. Capacitor charging requires little current, and therefore you can use a small-capacity power supply (2 A is sufficient).

The method for using a resistor (incandescent lamp) to charge the drive is described as follows:

If you directly connect the drive device to a power supply to charge the DC bus capacitor, it needs to be charged for a minimum of 60 minutes. The charging operation must be performed at a normal indoor temperature without load, and you must connect a resistor in series mode in the 3PH circuit of the power supply.

For a 380 V drive device, use a resistor of 1 k Ω /100W. If the voltage of the power supply is no higher than 380 V, you can also use an incandescent lamp of 100W. If an incandescent lamp is used, it may go off or the light may become very weak.

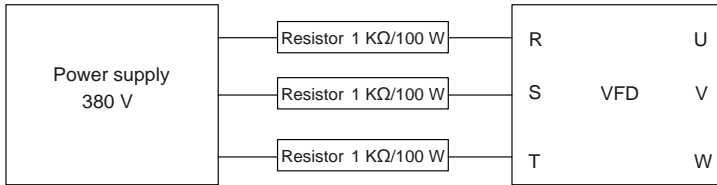

Figure 9-2 Charging circuit example of driving devices of 380V

9.4.2 Electrolytic capacitor replacement

	<p>✧ Read the safety precautions carefully and follow the instructions to perform operations. Ignoring these safety precautions may lead to physical injury or death, or device damage.</p>
--	---

The electrolytic capacitor of a VFD must be replaced if it has been used for more than 35,000 hours. For details about the replacement, contact the local INVT office.

9.5 Power cable

	<p>✧ Read the safety precautions carefully and follow the instructions to perform operations. Ignoring these safety precautions may lead to physical injury or death, or device damage.</p>
--	---

1. Stop the VFD, disconnect the power supply, and wait for a time no shorter than the waiting time designated on the VFD.
2. Check the connection of the power cables. Ensure that they are firmly connected.
3. Power on the VFD.

10 Communication protocol

10.1 What this chapter contains

This chapter describes the communication protocols supported by the VFD.

The VFD provides RS485 communication interfaces and adopts the master/slave communication based on the international standard Modbus/Modbus TCP communication protocol. You can implement centralized control (setting commands for controlling the VFD, modifying the running frequency and related function parameters, and monitoring the running status and fault information of the VFD) through PC/PLC, upper control computers, or other devices to meet specific application requirements.

10.2 Modbus protocol introduction

Modbus is a software protocol, a common language used in electronic controllers. By using this protocol, a controller can communicate with other devices through transmission lines. It is a general industrial standard. With this standard, control devices produced by different manufacturers can be connected to form an industrial network and be monitored in a centralized way.

The Modbus protocol provides two transmission modes, namely American Standard Code for Information Interchange (ASCII) and Remote Terminal Unit (RTU). On one Modbus network, all the device transmission modes, baud rates, data bits, check bits, end bits, and other basic parameters must be set consistently.

A Modbus network is a control network with one master and multiple slaves, that is, on one Modbus network, there is only one device serving as the master, and other devices are the slaves. The master can communicate with one slave or all the slaves by sending broadcast messages. For separate access commands, a slave needs to return a response. For broadcast messages, slaves do not need to return responses.

10.3 Application of Modbus

The VFD uses the Modbus RTU mode and communicates through RS485 interfaces.

10.3.1 RS485

RS485 interfaces work in half-duplex mode and send data signals in the differential transmission way, which is also referred to as balanced transmission. An RS485 interface uses a twisted pair, in which one wire is defined as A (+), and the other B (-). Generally, if the positive electrical level between the transmission drives A and B ranges from +2V to +6V, the logic is "1"; and if it ranges from -2V to -6V, the logic is "0". On the VFD terminal block, the 485+ terminal corresponds to A, and 485- corresponds to B.

The communication baud rate (P14.01) indicates the number of bits sent in a second, and the unit is bit/s (bps). A higher baud rate indicates faster transmission and poorer anti-interference capability. When a twisted pair of 0.56 mm (24 AWG) is used, the maximum transmission distance varies according to the baud rate, as described in the following table.

Baud rate (bps)	Max. transmission distance (meter)	Baud rate (bps)	Max. transmission distance (meter)
2400BPS	1800m	9600BPS	800m
4800BPS	1200m	19200BPS	600m

In long-distance RS485 communication, it is recommended that you use shielded cables, and use the shielding layer as the ground wire.

When there are fewer devices and the transmission distance is short, the whole network works well without terminal load resistors. The performance, however, degrades as the distance increases. Therefore, it is recommended that you use a 120 Ω terminal resistor when the transmission distance is long.

10.3.1.1 When one VFD is used

Figure 10-1 is the Modbus wiring diagram for the network with one VFD and PC. Generally, PCs do not provide RS485 interfaces, and therefore you need to convert an RS232 or USB interface of a PC to an RS485 interface through a converter. Then, connect end A of the RS485 interface to the 485+ port on the terminal block of the VFD, and connect end B to the 485- port. It is recommended that you use shielded twisted pairs. When an RS232-RS485 converter is used, the cable used to connect the RS232 interface of the PC and the converter cannot be longer than 15 m. Use a short cable when possible. It is recommended that you insert the converter directly into the PC. Similarly, when a USB-RS485 converter is used, use a short cable when possible.

When the wiring is completed, select the correct port (for example, COM1 to connect to the RS232-RS485 converter) for the upper computer of the PC, and keep the settings of basic parameters such as communication baud rate and data check bit consistent with those of the VFD.

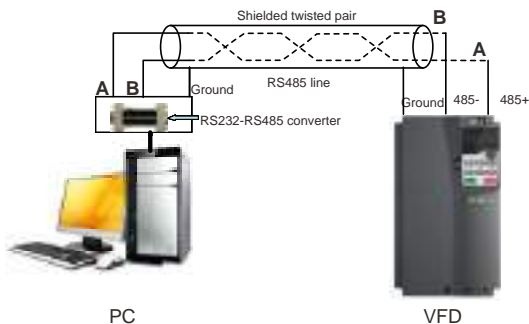

Figure 10-1 RS485 wiring diagram for the network with one VFD

10.3.1.2 When multiple VFDs are used

In the network with multiple VFDs, chrysanthemum connection and star connection are commonly used.

According to the requirements of the RS485 industrial bus standards, all the devices need to be connected in chrysanthemum mode with one 120 Ω terminal resistor on each end, as shown in Figure 10-2. Figure 10-3 simplified wiring diagram, and Figure 10-4 is the practical application diagram.

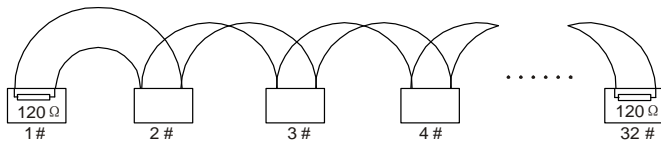

Figure 10-2 Onsite chrysanthemum connection diagram

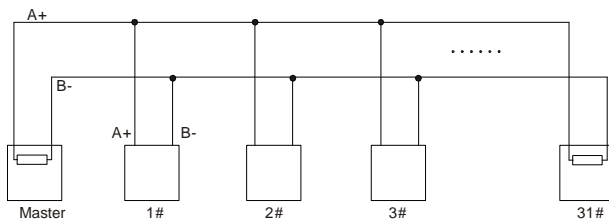

Figure 10-3 Simplified chrysanthemum connection diagram

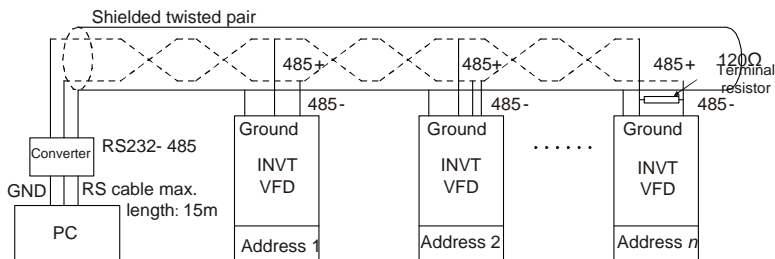

Figure 10-4 Practical application diagram of chrysanthemum connection

Figure 10-5 shows the start connection diagram. When this connection mode is adopted, the two devices that are farthest away from each other on the line must be connected with a terminal resistor (in this figure, the two devices are devices 1# and 15#).

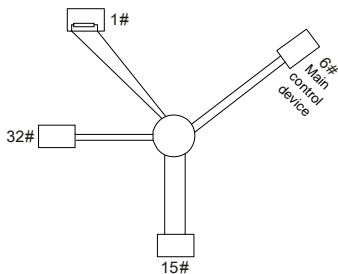

Figure 10-5 Star connection

Use shielded cable, if possible, in multi-VFD connection. The baud rates, data bit check settings, and other basic parameters of all the devices on the RS485 line must be set consistently, and addresses cannot be repeated.

10.3.2 RTU

10.3.2.1 RTU communication frame structure

When a controller is set to use the RTU communication mode on a Modbus network, every byte (8 bits) in the message includes 2 hexadecimal characters (each includes 4 bits). Compared with the ASCII mode, the RTU mode can send more data at the same baud rate.

Code system

- 1 start bit
- 7 or 8 data bits; the minimum valid bit is sent first. Each frame domain of 8 bits includes 2 hexadecimal characters (0–9, A–F).
- 1 odd/even check bit; this bit is not provided if no check is needed.
- 1 end bit (with check performed), 2 bits (without check)

Error detection domain

- Cyclic redundancy check (CRC)

The following tables provide the data formats.

11-bit character frame (Bits 1 to 8 are data bits)

Start bit	BIT1	BIT2	BIT3	BIT4	BIT5	BIT6	BIT7	BIT8	Check bit	End bit
-----------	------	------	------	------	------	------	------	------	-----------	---------

10-bit character frame (Bits 1 to 7 are data bits)

Start bit	BIT1	BIT2	BIT3	BIT4	BIT5	BIT6	BIT7	Check bit	End bit
-----------	------	------	------	------	------	------	------	-----------	---------

In a character frame, only the data bits carry information. The start bit, check bit, and end bit are used to facilitate the transmission of the data bits to the destination device. In practical applications, you must set the data bits, parity check bits, and end bits consistently.

In RTU mode, a new frame must be always preceded by a time gap with a minimum length of 3.5 bytes. On a network where the transmission rate is calculated based on the baud rate, the transmission time of 3.5 bytes can be easily obtained. After the idle time ends, the data domains are sent in the following sequence: slave address, operation command code, data, and CRC check character. Each byte sent in each domain includes 2 hexadecimal characters (0–9, A–F). The network devices always monitor the communication bus. After receiving the first domain (address information), each network device identifies the byte. After the last byte is sent, a similar transmission interval (with a minimum length of 3.5 bytes) is used to indicate that the frame transmission ends. Then, the transmission of a new frame starts.

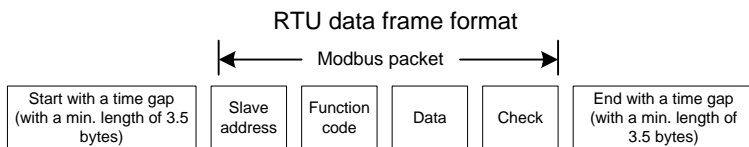

The information of a frame must be sent in a continuous data flow. If there is an interval greater than the transmission time of 1.5 bytes before the transmission of the entire frame is complete, the receiving device deletes the incomplete information, and mistakes the subsequent byte for the address domain of a new frame. Similarly, if the transmission interval between two frames is shorter than the transmission time of 3.5 bytes, the receiving device mistakes it for the data of the last frame. The CRC check value is incorrect due to the disorder of the frames, and thus a communication fault occurs.

The following table lists the standard structure of an RTU frame.

START (frame header)	T1-T2-T3-T4 (transmission time of 3.5 bytes)
ADDR (slave address domain)	Communication address: 0–247 (in decimal system) (0 indicates the broadcast address)
CMD (function domain)	03H: read slave parameters 06H: write slave parameters
DATA (N-1) ... DATA (0) (data domain)	Data of 2xN bytes, main content of the communication as well as the core of data exchanging
CRC CHK low-order bits	Detection value: CRC (16 bits)
CRC CHK high-order bits	
END (frame tail)	T1-T2-T3-T4 (transmission time of 3.5 bytes)

10.3.2.2 RTU communication frame error check modes

During the transmission of data, errors may occur due to various factors. Without check, the data receiving device cannot identify data errors and may make an incorrect response. The wrong response may cause severe problems. Therefore, the data must be checked.

The check is implemented as follows: The transmitter calculates the to-be-transmitted data based on a specific algorithm to obtain a result, adds the result to the rear of the message, and transmits them together. After receiving the message, the receiver calculates the data based on the same algorithm to obtain a result, and compares the result with that transmitted by the transmitter. If the results are the same, the message is correct. Otherwise, the message is considered wrong.

The error check of a frame includes two parts, namely, bit check on individual bytes (that is, odd/even check using the check bit in the character frame), and whole data check (CRC check).

Bit check on individual bytes (odd/even check)

You can select the bit check mode as required, or you can choose not to perform the check, which will affect the check bit setting of each byte.

Definition of even check: Before the data is transmitted, an even check bit is added to indicate whether the number of "1" in the to-be-transmitted data is odd or even. If it is even, the check bit is set to "0"; and if it is odd, the check bit is set to "1".

Definition of odd check: Before the data is transmitted, an odd check bit is added to indicate whether the number of "1" in the to-be-transmitted data is odd or even. If it is odd, the check bit is set to "0"; and if it is even, the check bit is set to "1".

For example, the data bits to be transmitted are "11001110", including five "1". If the even check is applied, the even check bit is set to "1"; and if the odd check is applied, the odd check bit is set to "0". During the transmission of the data, the odd/even check bit is calculated and placed in the check bit of the frame. The receiving device performs the odd/even check after receiving the data. If it finds that the odd/even parity of the data is inconsistent with the preset information, it determines that a communication error occurs.

CRC check mode

A frame in the RTU format includes an error detection domain based on the CRC calculation. The CRC domain checks all the content of the frame. The CRC domain consists of two bytes, including 16 binary bits. It is calculated by the transmitter and added to the frame. The receiver calculates the CRC of the received frame, and compares the result with the value in the received CRC domain. If the two CRC values are not equal to each other, errors occur in the transmission.

During CRC, 0xFFFF is stored first, and then a process is invoked to process a minimum of 6 contiguous bytes in the frame based on the content in the current register. CRC is valid only for the 8-bit data in each character. It is invalid for the start, end, and check bits.

During the generation of the CRC values, the "exclusive or" (XOR) operation is performed on the each 8-bit character and the content in the register. The result is placed in the bits from the least

significant bit (LSB) to the most significant bit (MSB), and 0 is placed in the MSB. Then, LSB is detected. If LSB is 1, the XOR operation is performed on the current value in the register and the preset value. If LSB is 0, no operation is performed. This process is repeated 8 times. After the last bit (8th bit) is detected and processed, the XOR operation is performed on the next 8-bit byte and the current content in the register. The final values in the register are the CRC values obtained after operations are performed on all the bytes in the frame.

The calculation adopts the international standard CRC check rule. You can refer to the related standard CRC algorithm to compile the CRC calculation program as required.

The following example is a simple CRC calculation function for your reference (using the C programming language):

```
unsigned int  crc_cal_value(unsigned char*data_value,unsigned char
data_length)
{
    int i;
    unsigned int crc_value=0xffff;
    while(data_length--)
    {
        crc_value^=*data_value++;
        for(i=0;i<8;i++)
        {
            if(crc_value&0x0001)
                crc_value=(crc_value>>1)^0xa001;
            else
                crc_value=crc_value>>1;
        }
    }
    return(crc_value);
}
```

In the ladder logic, CKSM uses the table look-up method to calculate the CRC value according to the content in the frame. The program of this method is simple, and the calculation is fast, but the ROM space occupied is large. Use this program with caution in scenarios where there are space occupation requirements on programs.

10.4 RTU command code and communication data

10.4.1 Command code 03H, reading N words (continuously up to 16 words)

The command code 03H is used by the master to read data from the VFD. The count of data to be read depends on the "data count" in the command. A maximum of 16 pieces of data can be read. The addresses of the read parameters must be contiguous. Each piece of data occupies 2 bytes, that is, one word. The command format is presented using the hexadecimal system (a number followed by

"H" indicates a hexadecimal value). One hexadecimal value occupies one byte.

The 03H command is used to read information including the parameters and running status of the VFD.

For example, starting from the data address of 0004H, to read two contiguous pieces of data (that is, to read content from the data addresses 0004H and 0005H), the frame structures are described in the following.

RTU master command (from the master to the VFD)

START	T1-T2-T3-T4 (time gap with a min. length of 3.5 bytes)
ADDR (address)	01H
CMD (command code)	03H
Start address high-order bits	00H
Start address low-order bits	04H
Data count high-order bits	00H
Data count low-order bits	02H
CRC low-order bits	85H
CRC high-order bits	CAH
END	T1-T2-T3-T4 (time gap with a min. length of 3.5 bytes)

"START" and "END" are "T1-T2-T3-T4 (time gap with a min. length of 3.5 bytes)", indicating that a time gap with a minimum length of 3.5 bytes must be kept before RS485 communication is executed. The time gap is used to distinguish one message from another so that the two messages are not regarded as one message.

"ADDR" is "01H", indicating that the command is sent to the VFD whose address is 01H. The ADDR information occupies one byte.

"CMD" is "03H", indicating that the command is used to read data from the VFD. The CMD information occupies one byte.

"Start address" indicates that data reading is started from this address. It occupies two bytes, with the MSB on the left and LSB on the right.

"Data count" indicates the count of data to be read (unit: word). "Start address" is "0004H" and "Data count" is 0002H, indicating that data is to be read from the data addresses of 0004H and 0005H.

CRC check occupies two bytes, with the LSB on the left and MSB on the right.

CRC check occupies two bytes, with the LSB on the left, and MSB on the right.

RTU slave response (from the VFD to the master)

START	T1-T2-T3-T4 (time gap with a min. length of 3.5 bytes)
ADDR	01H

CMD	03H
Number of bytes	04H
High-order bits in 0004H	13H
Low-order bits in 0004H	88H
High-order bits in 0005H	00H
Low-order bits in 0005H	00H
CRC low-order bits	7EH
CRC high-order bits	9DH
END	T1-T2-T3-T4 (time gap with a min. length of 3.5 bytes)

The definition of the response information is described as follows:

"ADDR" is "01H", indicating that the message is sent from the VFD whose address is 01H. The ADDR information occupies one byte.

"CMD" is "03H", indicating that the message is a VFD response to the 03H command from the master for reading data. The CMD information occupies one byte.

"Number of bytes" indicates the number of bytes between a byte (not included) and the CRC byte (not included). The value "04" indicates that there are four bytes of data between "Number of bytes" and "CRC LSB", that is, "High-order bits in 0004H", "Low-order bits in 0004H", "High-order bits in 0005H", and "Low-order bits in 0005H".

A piece of data is two bytes, with the MSB on the left and LSB on the right. From the response, the data in 0004H is 1388H, and that in 0005H is 0000H.

CRC check occupies two bytes, with the low-order bits on the left and high-order bits on the right.

10.4.2 Command code 06H, writing a word

This command is used by the master to write data to the VFD. One command can be used to write only one piece of data. It is used to modify the parameters and running mode of the VFD.

For example, to write 5000 (1388H) to 0004H of the VFD whose address is 02H, the frame structures are described in the following.

RTU master command (from the master to the VFD)

START	T1-T2-T3-T4 (time gap with a min. length of 3.5 bytes)
ADDR	02H
CMD	06H
High-order bits of data writing address	00H

Low-order bits of data writing address	04H
High-order bits of to-be-written data	13H
Low-order bits of to-be-written data	88H
CRC low-order bits	C5H
CRC high-order bits	6EH
END	T1-T2-T3-T4 (time gap with a min. length of 3.5 bytes)

RTU slave response (from the VFD to the master)

START	T1-T2-T3-T4 (time gap with a min. length of 3.5 bytes)
ADDR	02H
CMD	06H
High-order bits of data writing address	00H
Low-order bits of data writing address	04H
Data content high-order bits	13H
Data content low-order bits	88H
CRC low-order bits	C5H
CRC high-order bits	6EH
END	T1-T2-T3-T4 (time gap with a min. length of 3.5 bytes)

Note: Sections 10.4.1 and 10.4.2 mainly describe the command formats. For the detailed application, see section 10.4.8.

10.4.3 Command code 08H, diagnosis

Sub-function code description:

Sub-function code	Description
0000	Return data based on query requests

For example, to query about the circuit detection information about the VFD whose address is 01H, the query and return strings are the same, and the format is described as follows.

RTU master command:

START	T1-T2-T3-T4 (time gap with a min. length of 3.5 bytes)
ADDR	01H
CMD	08H
Sub-function code high-order bits	00H
Sub-function code low-order bits	00H
Data content high-order bits	12H

Data content low-order bits	ABH
CRC CHK low-order bits	ADH
CRC CHK high-order bits	14H
END	T1-T2-T3-T4 (time gap with a min. length of 3.5 bytes)

RTU slave response:

START	T1-T2-T3-T4 (time gap with a min. length of 3.5 bytes)
ADDR	01H
CMD	08H
Sub-function code high-order bits	00H
Sub-function code low-order bits	00H
Data content high-order bits	12H
Data content low-order bits	ABH
CRC CHK low-order bits	ADH
CRC CHK high-order bits	14H
END	T1-T2-T3-T4 (time gap with a min. length of 3.5 bytes)

10.4.4 Command code 10H, continuous writing

The command code 10H is used by the master to write data to the VFD. The quantity of data to be written is determined by "Data quantity", and a maximum of 16 pieces of data can be written.

For example, to write 5000 (1388H) and 50 (0032H) respectively to 0004H and 0005H of the VFD whose slave address is 02H, the frame structure is as follows.

RTU master command (from the master to the VFD)

START	T1-T2-T3-T4 (time gap with a min. length of 3.5 bytes)
ADDR	02H
CMD	10H
High-order bits of data writing address	00H
Low-order bits of data writing address	04H
Data count high-order bits	00H
Data count low-order bits	02H
Number of bytes	04H
High-order bits in 0004H	13H
Low-order bits in 0004H	88H
High-order bits in 0005H	00H
Low-order bits in 0005H	32H

CRC low-order bits	C5H
CRC high-order bits	6EH
END	T1-T2-T3-T4 (time gap with a min. length of 3.5 bytes)

RTU slave response (from the VFD to the master)

START	T1-T2-T3-T4 (time gap with a min. length of 3.5 bytes)
ADDR	02H
CMD	10H
High-order bits of data writing address	00H
Low-order bits of data writing address	04H
Data count high-order bits	00H
Data count low-order bits	02H
CRC low-order bits	C5H
CRC high-order bits	6EH
END	T1-T2-T3-T4 (time gap with a min. length of 3.5 bytes)

10.4.5 Data address definition

This section describes the address definition of communication data. The addresses are used for controlling the running, obtaining the state information, and setting related function parameters of the VFD.

10.4.5.1 Function code address format rules

The address of a function code consists of two bytes, with the high-order bits on the left and low-order bits on the right. The high-order bits ranges from 00 to ffH, and the low-order bits also ranges from 00 to ffH. The high-order bits is the hexadecimal form of the group number before the dot mark, and low-order bits is that of the number behind the dot mark. Take P05.06 as an example: The group number is 05, that is, the high-order bits of the parameter address is the hexadecimal form of 05; and the number behind the dot mark is 06, that is, the low-order bits is the hexadecimal form of 06. Therefore, the function code address is 0506H in the hexadecimal form. For example, the parameter address of P10.01 is 0A01H.

Function code	Name	Description	Setting range	Default	Modify
P10.00	Simple PLC mode	0: Stop after running once 1: Keep running with the final value after running once 2: Cyclic running	0-2	0	○
P10.01	Simple PLC memory selection	0: No power-failure memory 1: With power-failure memory	0-1	0	○

Note:

- The parameters in the P99 group are set by the manufacturer and cannot be read or modified. Some parameters cannot be modified when the VFD is running; some cannot be modified regardless of the VFD status. Pay attention to the setting range, unit, and description of a parameter when modifying it.
- The service life of the Electrically Erasable Programmable Read-Only Memory (EEPROM) may be reduced if it is frequently used for storage. Some function codes do not need to be stored during communication. The application requirements can be met by modifying the value of the on-chip RAM, that is, modifying the MSB of the corresponding function code address from 0 to 1. For example, if P00.07 is not to be stored in the EEPROM, you need only to modify the value in the RAM, that is, set the address to 8007H. The address can be used only for writing data to the on-chip RAM, and it is invalid when used for reading data.

10.4.5.2 Description of other Modbus function addresses

In addition to modifying the parameters of the VFD, the master can also control the VFD, such as starting and stopping it, and monitoring the operation status of the VFD. The following table describes other function parameters.

Function	Address	Data description	R/W
Communication-based control command	2000H	0001H: Run forward	R/W
		0002H: Run reversely	
		0003H: Jog forward	
		0004H: Jog reversely	
		0005H: Stop	
		0006H: Coast to stop (in emergency)	
		0007H: Fault reset	
		0008H: Jogging to stop	
Communication-based setting address	2001H	Communication-based frequency setting (0–Fmax; unit: 0.01 Hz)	R/W
	2002H	PID reference (0–1000, in which 1000 corresponds to 100.0%)	R/W
	2003H	PID feedback (0–1000, in which 1000 corresponds to 100.0%)	R/W
	2004H	Torque setting (-3000–3000, in which 1000 corresponds to 100.0% of the motor rated current)	R/W
	2005H	Upper limit setting of forward running frequency (0–Fmax; unit: 0.01 Hz)	R/W
	2006H	Upper limit setting of reverse running frequency (0–Fmax; unit: 0.01 Hz)	R/W
	2007H	Upper limit of the electromotion torque (0–3000, 1000)	R/W

Function	Address	Data description	R/W
		corresponding to 100.0% of the motor rated current)	
	2008H	Braking torque upper limit. (0–3000, in which 1000 corresponds to 100.0% of the VFD rated current)	R/W
	2009H	Special CW Bit0–1=00: Motor 1 =01: Motor 2 Bit2=1 Enable speed/torque control switchover =0: Disable speed/torque control switchover Bit3=1 Clear electricity consumption data =0: Keep electricity consumption data Bit4=1 Enable pre-excitation =0: Disable pre-excitation Bit5=1 Enable DC braking =0: Disable DC braking	R/W
	200AH	Virtual input terminal command (0x000–0x3FF) Corresponding to S8/S7/S6/S5/HDIB/HDIA/S4/ S3/S2/S1	R/W
	200BH	Virtual output terminal command (0x00–0x0F) Corresponding to local RO2/RO1/HDO/Y1	R/W
	200CH	Voltage setting (used when V/F separation is implemented) (0–1000, 1000 corresponding to 100.0% of the motor rated voltage)	R/W
	200DH	AO setting 1 (-1000→+1000, in which 1000 corresponding to 100.0%)	R/W
	200EH	AO setting 2 (-1000→+1000, in which 1000 corresponding to 100.0%)	R/W
VFD status word 1	2100H	0001H: Forward running 0002H: Reverse running 0003H: Stopped 0004H: Faulty 0005H: POFF 0006H: Pre-exciting	R
VFD status word 2	2101H	Bit0: =0: Not ready to run =1: Ready to run Bit1–2=00: Motor 1 =01: Motor 2 Bit3: =0: AM =1: SM Bit4=0: No overload pre-alarm =1: Overload pre-alarm Bit5–Bit6=00: Keypad-based control =01: Terminal-based control	R

Function	Address	Data description	R/W																										
		=10: Communication-based control Bit7: Reserved Bit8=0: Speed control =1: Torque control Bit9=0: Non position control =1: Position control Bit10–Bit11: =0: Vector 0 =1: Vector 1 =2: Closed-loop vector = 3: Space voltage vector																											
VFD fault code	2102H	See the description of fault types.	R																										
VFD identification code	2103H	GD350-----0x01A0	R																										
Running frequency	3000H	0–Fmax (Unit: 0.01Hz)	R																										
Set frequency	3001H	0–Fmax (Unit: 0.01Hz)	R																										
Bus voltage	3002H	0.0–2000.0V (Unit: 0.1V)	R																										
Output voltage	3003H	0–1200V (Unit: 1V)	R																										
Output current	3004H	0.0–3000.0A (Unit: 0.1A)	R																										
Rotational speed	3005H	0–65535 (Unit: 1RPM)	R																										
Output power	3006H	-300.0–300.0% (Unit: 0.1%)	R																										
Output torque	3007H	-250.0–250.0% (Unit: 0.1%)	R																										
Closed-loop setting	3008H	-100.0–100.0% (Unit: 0.1%)	R																										
Closed-loop feedback	3009H	-100.0–100.0% (Unit: 0.1%)	R																										
Input state	300AH	0000–FFF	Compatible with CHF100A and CHV100 communication addresses																										
		<table border="1"> <tr> <td>bit11</td> <td>bit10</td> <td>bit9</td> <td>bit8</td> <td>bit7</td> <td>bit6</td> </tr> <tr> <td>S8</td> <td>S7</td> <td>S6</td> <td>S5</td> <td>/</td> <td>/</td> </tr> <tr> <td>bit5</td> <td>bit4</td> <td>bit3</td> <td>bit2</td> <td>bit1</td> <td>bit0</td> </tr> <tr> <td>HDIB</td> <td>HDIA</td> <td>S4</td> <td>S3</td> <td>S2</td> <td>S1</td> </tr> </table>		bit11	bit10	bit9	bit8	bit7	bit6	S8	S7	S6	S5	/	/	bit5	bit4	bit3	bit2	bit1	bit0	HDIB	HDIA	S4	S3	S2	S1		
		bit11		bit10	bit9	bit8	bit7	bit6																					
		S8		S7	S6	S5	/	/																					
bit5	bit4	bit3		bit2	bit1	bit0																							
HDIB	HDIA	S4		S3	S2	S1																							
<table border="1"> <tr> <td>bit13</td> <td>bit12</td> <td>bit11</td> <td>bit10</td> <td>bit9</td> <td>bit8</td> <td>bit7</td> </tr> <tr> <td>/</td> <td>RO4</td> <td>RO3</td> <td>/</td> <td>/</td> <td>Y2</td> <td>/</td> </tr> <tr> <td>bit6</td> <td>bit5</td> <td>bit4</td> <td>bit3</td> <td>bit2</td> <td>bit1</td> <td>bit0</td> </tr> <tr> <td>/</td> <td>/</td> <td>/</td> <td>RO2</td> <td>RO1</td> <td>HDO</td> <td>Y1</td> </tr> </table>	bit13	bit12		bit11	bit10	bit9	bit8	bit7	/	RO4	RO3	/	/	Y2	/	bit6	bit5	bit4	bit3	bit2	bit1	bit0	/	/	/	RO2	RO1	HDO	Y1
bit13	bit12	bit11		bit10	bit9	bit8	bit7																						
/	RO4	RO3		/	/	Y2	/																						
bit6	bit5	bit4		bit3	bit2	bit1	bit0																						
/	/	/	RO2	RO1	HDO	Y1																							
Output state	300BH	000–1FFF																											
Analog input 1	300CH	0.00–10.00V (Unit: 0.01V)	R																										
Analog input 2	300DH	0.00–10.00V (Unit: 0.01V)	R																										
Analog input 3	300EH	-10.00–10.00V (Unit: 0.01V)	R																										
Analog input 4	300FH		R																										
Read input of HDIA high-speed pulse	3010H	0.00–50.00kHz (Unit: 0.01Hz)	R																										

Function	Address	Data description		R/W
Read input of HDIB high-speed pulse	3011H			R
Read the actual step of multi-step speed	3012H	0–15		R
External length value	3013H	0–65535		R
External counting value	3014H	0–65535		R
Torque setting	3015H	-300.0–300.0% (Unit: 0.1%)		R
VFD identification code	3016H			R
Fault code	5000H			R

The Read/Write (R/W) characteristics indicate whether a function parameter can be read and written. For example, "Communication-based control command" can be written, and therefore the command code 06H is used to control the VFD. The R characteristic indicates that a function parameter can only be read, and W indicates that a function parameter can only be written.

Note: Some parameters in the preceding table are valid only after they are enabled. Take the running and stop operations as examples, you need to set "Running command channel" (P00.01) to "Communication", and set "Communication running command channel" (P00.02) to the Modbus/Modbus TCP communication channel. For another example, when modifying "PID setting", you need to set "PID reference source" (P09.00) to Modbus/Modbus TCP communication.

The following table describes the encoding rules of device codes (corresponding to the identification code 2103H of the VFD).

8 high-order bits	Meaning	8 low-order bits	Meaning
01	GD	0x08	GD35 vector VFD
		0x09	GD35-H1 vector VFD
		0x0a	GD300 vector VFD
		0xa0	GD350 vector VFD

10.4.6 Fieldbus scale

In practical applications, communication data is represented in the hexadecimal form, but hexadecimal values cannot represent decimals. For example, 50.12 Hz cannot be represented in the hexadecimal form. In such cases, multiply 50.12 by 100 to obtain an integer 5012, and then 50.12 can be represented as 1394H in the hexadecimal form (5012 in the decimal form).

In the process of multiplying a non-integer by a multiple to obtain an integer, the multiple is referred to as a fieldbus scale.

The fieldbus scale depends on the number of decimals in the value specified in "Detailed parameter description" or "Default value". If there are n decimals in the value, the fieldbus scale m is the

n^{th} -power of 10. Take the following table as an example, m is 10.

Function code	Name	Description	Setting range	Default	Modify
P01.20	Wake-up-from-sleep delay	0.0–3600.0s (valid when P01.19 is 2)	0.00–3600.0	0.0s	<input type="radio"/>
P01.21	Power-off restart selection	0: Disable restart 1: Enable restart	0–1	0	<input type="radio"/>

The value specified in "Setting range" or "Default" contains one decimal place, and therefore the fieldbus scale is 10. If the value received by the upper computer is 50, the value of "Wake-up-from-sleep delay" of the VFD is 5.0 (5.0=50/10).

To set "Wake-up-from-sleep delay" to 5.0s through Modbus/Modbus TCP communication, you need first to multiply 5.0 by 10 according to the scale to obtain an integer 50, that is, 32H in the hexadecimal form, and then send the following write command:

01 06 01 14 00 32 49 E7
 VFD Write Parameter Parameter CRC
 address command address data

After receiving the command, the VFD converts 50 into 5.0 based on the fieldbus scale, and then sets "Wake-up-from-sleep delay" to 5.0s.

For another example, after the upper computer sends the "Wake-up-from-sleep delay" parameter read command, the master receives the following response from the VFD:

01 03 02 00 32 39 91
 VFD Read 2-byte Parameter CRC
 address command data data

The parameter data is 0032H, that is, 50, and therefore 5.0 is obtained based on the fieldbus scale (50/10=5.0). In this case, the master identifies that "Wake-up-from-sleep delay" is 5.0s.

10.4.7 Error message response

Operation errors may occur in communication-based control. For example, some parameters can only be read, but a write command is sent. In this case, the VFD returns an error message response.

Error message responses are sent from the VFD to the master. The following table lists the codes and definitions of the error message responses.

Code	Name	Definition
01H	Invalid command	The command code received by the upper computer is not allowed to be executed. The possible causes are as follows: The function code is applicable only on new devices and is not implemented on this device.

Code	Name	Definition
		The slave is in the faulty state when processing this request.
02H	Invalid data address	For the VFD, the data address in the request of the upper computer is not allowed. In particular, the combination of the register address and the number of the to-be-sent bytes is invalid.
03H	Invalid data value	The received data domain contains a value that is not allowed. The value indicates the error of the remaining structure in the combined request. Note: It does not mean that the data item submitted for storage in the register includes a value unexpected by the program.
04H	Operation failure	The parameter is set to an invalid value in the write operation. For example, a function input terminal cannot be set repeatedly.
05H	Incorrect password	The password entered in the password verification address is different from that set by P07.00.
06H	Incorrect data frame	The data frame sent from the upper computer is incorrect in the length, or in the RTU format, the value of the CRC check bit is inconsistent with the CRC value calculated by the lower computer.
07H	Parameter read-only	The parameter to be modified in the write operation of the upper computer is a read-only parameter.
08H	Parameter cannot be modified in running	The parameter to be modified in the write operation of the upper computer cannot be modified during the running of the VFD.
09H	Password protection	If the upper computer does not provide the correct password to unlock the system to perform a read or write operation, the error of "system being locked" is reported.

When returning a response, the slave uses a function code domain and fault address to indicate whether it is a normal response (no error) or exception response (an error occurs). In a normal response, the slave returns the corresponding function code and data address or sub-function code. In an exception response, the slave returns a code that is equal to a normal code, but the first bit is logic 1.

For example, if the master sends a request message to a slave for reading a group of function code address data, the following code is generated:

0 0 0 0 0 1 1 (03H in the hexadecimal form)

For a normal response, the same code is returned.

For an exception response, the following code is returned:

1 0 0 0 0 1 1 (83H in the hexadecimal form)

In addition to the modification of the code, the slave returns a byte of exception code that describes

the cause of the exception. After receiving the exception response, the typical processing of the master is to send the request message again or modify the command based on the fault information.

For example, to set the "Running command channel" (P00.01, the parameter address is 0001H) of the VFD whose address is 01H to 03, the command is as follows:

<u>01</u>	<u>06</u>	<u>00 01</u>	<u>00 03</u>	<u>98 0B</u>
VFD address	Write command	Parameter address	Parameter data	CRC

However, the "Running command channel" ranges from 0 to 2. The value 3 is out of the setting range. In this case, the VFD returns an error message response as shown in the following:

<u>01</u>	<u>86</u>	<u>04</u>	<u>43 A3</u>
VFD address	Exception response code	Error code	CRC

The exception response code 86H (generated based on the highest-order bit "1" of the write command 06H) indicates that it is an exception response to the write command (06H). The error code is 04H, which indicates "Operation failure".

10.4.8 Read/Write operation examples

For the formats of the read and write commands, see section 10.4.1 and 10.4.2.

10.4.8.1 Read command 03H examples

Example 1: Read status word 1 of the VFD whose address is 01H. From the table of other function parameters, we can see that the parameter address of status word 1 of the VFD is 2100H.

The read command transmitted to the VFD is as follows:

<u>01</u>	<u>03</u>	<u>21 00</u>	<u>00 01</u>	<u>8E 36</u>
VFD address	Read command	Parameter address	Data quantity	CRC

Assume that the following response is returned:

<u>01</u>	<u>03</u>	<u>02</u>	<u>00 03</u>	<u>F8 45</u>
VFD address	Read command	Number of bytes	Data content	CRC

The data content returned by the VFD is 0003H, which indicates that the VFD is in the stopped state.

Example 2: View information about the VFD whose address is 03H, including "Type of current fault" (P07.27) to "Type of last but four fault" (P07.32) of which the parameter addresses are 071BH to 0720H (contiguous 6 parameter addresses starting from 071BH).

The command transmitted to the VFD is as follows:

<u>03</u>	<u>03</u>	<u>07 1B</u>	<u>00 06</u>	<u>B5 59</u>
VFD address	Read command	Start address	6 parameters in total	CRC

Assume that the following response is returned:

03 03 0C 00 23 00 23 00 23 00 23 00 23 00 23 5F D2
VFD Read Number of Type of Type of Type of last Type of last Type of last Type of last CRC
address command bytes current fault last fault but one fault but two fault but three fault but four fault

According to the returned data, all the fault types are 0023H, that is, 35 in the decimal form, which means the maladjustment fault (STo).

10.4.8.2 Write command 06H examples

Example 1: Set the VFD whose address is 03H to be forward running. Refer to the table of other function parameters, the address of "Communication-based control command" is 2000H, and 0001H indicates forward running, as shown in the following figure.

Function	Address	Data description	R/W
Communication-based control command	2000H	0001H: Run forward	R/W
		0002H: Run reversely	
		0003H: Jog forward	
		0004H: Jog reversely	
		0005H: Stop	
		0006H: Coast to stop (in emergency)	
		0007H: Fault reset	
		0008H: Jogging to stop	

The command transmitted by the master is as follows:

03 06 20 00 00 01 42 28
VFD Write Parameter Forward CRC
address command address running

If the operation is successful, the following response is returned (same as the command transmitted by the master):

03 06 20 00 00 01 42 28
VFD Write Parameter Forward CRC
address command address running

Example 2: Set the max. output frequency to 100 Hz for the VFD with the address of 03H.

Function code	Name	Description	Setting range	Default	Modify
P00.03	Max. output frequency	P00.04–600.00H (400.00Hz)	100.00–600.00	50.00Hz	☉

According to the number of decimals, the fieldbus scale of the "Max. output frequency" (P00.03) is 100. Multiply 100 Hz by 100. The value 10000 is obtained, and it is 2710H in the hexadecimal form.

The command transmitted by the master is as follows:

03 **06** **00 03** **27 10** **62 14**
 VFD Write Parameter Parameter CRC
 address command address data

If the operation is successful, the following response is returned (same as the command transmitted by the master):

03 **06** **00 03** **27 10** **62 14**
 VFD Write Parameter Parameter CRC
 address command address data

Note: In the preceding command description, spaces are added to a command just for explanatory purposes. In practical applications, no space is required in the commands.

10.4.8.3 Example of continuously writing command 10H

Example 1: Set the VFD whose address is 01H to be forward running at the frequency of 10 Hz. Refer to the table of other function parameters, the address of "Communication-based control command" is 2000H, 0001H indicates forward running, and the address of "Communication-based value setting" is 2001H, as shown in the following figure. 10 Hz is 03E8H in the hexadecimal form.

Function	Address	Data description	R/W
Communication-based control command	2000H	0001H: Run forward	R/W
		0002H: Run reversely	
		0003H: Jog forward	
		0004H: Jog reversely	
		0005H: Stop	
		0006H: Coast to stop (in emergency)	
		0007H: Fault reset	
		0008H: Jogging to stop	
Communication-based setting address	2001H	Communication-based frequency setting (0–Fmax; unit: 0.01 Hz)	R/W
	2002H	PID reference (0–1000, in which 1000 corresponds to 100.0%)	

In the actual operation, set P00.01 to 2 and P00.06 to 8.

The command transmitted by the master is as follows:

01 **10** **20 00** **00 02** **04** **00 01** **03 E8** **3B 10**
 VFD Continuous Parameter Parameter Number of Forward 10 Hz CRC
 address write address quantity bytes running

If the operation is successful, the following response is returned:



First, set the serial port to **COM1**. Then, set the baud rate consistently with P14.01. The data bits, check bits, and end bits must be set consistently with P14.02. If the RTU mode is selected, you need to select the hexadecimal form **Input HEX**. To set the software to automatically execute the CRC function, you need to select **ModbusRTU**, select **CRC16 (MODBU SRTU)**, and set the start byte to **1**. After the auto CRC check function is enabled, do not enter CRC information in commands. Otherwise, command errors may occur due to repeated CRC check.

The commissioning command to set the VFD whose address is 03H to be forward running is as follows:

<u>03</u>	<u>06</u>	<u>20 00</u>	<u>00 01</u>	<u>42 28</u>
VFD address	Write command	Parameter address	Forward running	CRC

Note:

- Set the address (P14.00) of the VFD to 03.
- Set "Channel of running commands" (P00.01) to "Communication", and set "Communication channel of running commands" (P00.02) to the Modbus/Modbus TCP communication channel.
- Click **Send**. If the line configuration and settings are correct, a response transmitted by the VFD is received as follows:

<u>03</u>	<u>06</u>	<u>20 00</u>	<u>00 01</u>	<u>42 28</u>
VFD address	Write command	Parameter address	Forward running	CRC

10.4.9 Common communication faults

Common communication faults include the following:

- No response is returned.
- The VFD returns an exception response.

Possible causes of no response include the following:

- The serial port is set incorrectly. For example, the converter uses the serial port COM1, but COM2 is selected for the communication.
- The settings of the baud rates, data bits, end bits, and check bits are inconsistent with those set on the VFD.
- The positive pole (+) and negative pole (-) of the RS485 bus are connected reversely.
- The resistor connected to 485 terminals on the terminal block of the VFD is set incorrectly.

11 CW and SW module for port crane applications

In port crane applications, CANopen, PROFIBUS, PROFINET, and EtherNet IP communication control words (CWs) and status words (SWs) are controlled by bit. INVT CWs and SWs are expressed in format of value. You can choose the CWs and SWs special for port crane applications or INVT standard CWs and SWs based on your requirements.

Function code	Name	Description	Setting
P16.72	CW and SW selection	0–1 0: Standard CWs and SWs 1: CWs and SWs for port crane applications	1

11.1 CWs for port crane applications

Bit	Name	Value	State/Description
0	COMMAND BYTE Communication-based control command	1	Run forward
1		1	Run reversely
2		1	Jog forward
3		1	Jog reversely
4		1	Decelerate to stop
5		1	Emergency stop
6		1	Fault reset
7		1	Enabling run
8	Enabling hook synchronization (Reserved)	1	Enable
		0	Disable
9–10	MOTOR GROUP SELECTION	00	MOTOR GROUP 1 SELECTION
		01	MOTOR GROUP 2 SELECTION
		02	MOTOR GROUP 3 SELECTION
		03	MOTOR GROUP 4 SELECTION
11	Torque/speed switchover	1	Switch to torque control
		0	Switch to speed control
12	External fault	1	External fault
13	PRE-EXCIATION	1	Enable
		0	Disable
14	Torque limit setting (Reserved)	1	Valid
		0	Invalid
15	Zero-torque giving	1	Enable
		0	Disable

11.2 SWs for port crane applications

Bit	Name	Value	State/Description
0	RUN STATUS BYTE	1	Running forward
1		1	Running reversely
2		1	Stopped
3		1	In fault
4		1	Ready
5		1	Pre-exciting
6		1	Brake closed
7		1	Warning
8	Multi-step speed terminal status	1	Status of multi-step speed terminal 1
9		1	Status of multi-step speed terminal 2
10		1	Status of multi-step speed terminal 3
11		1	Status of multi-step speed terminal 4
12–13	Motor group feedback	0(0x00)	Feedback from motor 1
		1(0x01)	Feedback from motor 2
		2(0x10)	Feedback from motor 3
		3(0x11)	Feedback from motor 4 (Reserved)
14–15	Run mode selection	0(0x00)	Keypad controlled
		1(0x01)	Terminal controlled
		2(0x10)	Communication controlled
		3(0x11)	Reserved

11.3 CANopen/PROFIBUS DP PZD communication

Received parameters

Function code	Name	Description
P15.02	Received PZD2	0: Disable 1: Set frequency (0–Fmax (Unit: 0.01Hz)) 2: PID reference (-1000–1000, in which 1000 corresponds to 100.0%) 3: PID feedback (-1000–1000, in which 1000 corresponds to 100.0%) 4: Torque setting (-3000–+3000, in which 1000 corresponds to 100.0% of the motor rated current) 5: Setting of the upper limit of forward running frequency (0–Fmax, unit: 0.01 Hz) 6: Setting of the upper limit of reverse running frequency (0–Fmax, unit: 0.01 Hz)
P15.03	Received PZD3	
P15.04	Received PZD4	
P15.05	Received PZD5	
P15.06	Received PZD6	
P15.07	Received PZD7	
P15.08	Received PZD8	
P15.09	Received PZD9	
P15.10	Received PZD10	
P15.11	Received PZD11	
P15.12	Received PZD12	

Function code	Name	Description
		7: Upper limit of the electromotive torque (0–3000, in which 1000 corresponds to 100.0% of the motor rated current) 8: Upper limit of braking torque (0–3000, in which 1000 corresponds to 100% of the motor rated current) 9: Virtual input terminal command. Range: 0x0000–0x3FFF (Corresponding to S12/S11/S10/S9/S8/S7/S6/S5/HDIB/HDIA/S4/S3/S2/S1 in sequence) 10: Virtual output terminal command. Range: 0x00–0x0F (Corresponding to RO2/RO1/HDO/Y1 in sequence) 11: Voltage setting (special for V/F separation) (0–1000, in which 1000 corresponds to 100% of the motor rated voltage) 12: AO1 output setting 1 (-1000→+1000, in which 1000 corresponds to 100.0%) 13: AO2 output setting 2 (-1000→+1000, in which 1000 corresponds to 100.0%) 14: High-order bit of position reference (signed) 15: Low-order bit of position reference (unsigned) 16: High-order bit of position feedback (signed) 17: Low-order bit of position feedback (unsigned) 18: Position feedback setting flag (position feedback can be set only after this flag is set to 1 and then to 0) 19–20: Reserved 21: Non standard frequency giving 22–25: Reserved 26: Reference encoder pulse high-order bits 27: Reference encoder pulse low-order bits 28–46: Reserved 47: ACC time (0–1000 corresponding to 0.0–100.0s) 48: DEC time (0–1000 corresponding to 0.0–100.0s) 49: Function code mapping (PZD2 to PZD12 correspond to P14.49 to P14.59.)

When encoder pulses are used, P20.15 must be used together.

Function code	Name	Description	Setting
P20.15	Speed	24: Pulses are obtained through CANopen or	2

Function code	Name	Description	Setting
	measurement mode	PROFIBUS-DP communication to measure the speed.	

When ACC/DEC time is used, P16.73 must be used together.

Function code	Name	Description	Setting
P16.73	Communication set ACC/DEC time selection	1: PROFIBUS DP or CANopen communication	1

For function code mapping, it must be used together with P14.48–P14.59.

Function code	Name	Description	Setting
P14.48	Channel selection for mapping between PZDs and function codes	0x00–0x12 Ones place: Channel for mapping function codes to PZDs 0: Reserved 1: Group P15 2: Group P16 Tens place: Save function at power failure 0: Disable 1: Enable	0x12
P14.49	Mapped function code of received PZD2	0x0000–0xFFFF	0x0000
P14.50	Mapped function code of received PZD3	0x0000–0xFFFF	0x0000
P14.51	Mapped function code of received PZD4	0x0000–0xFFFF	0x0000
P14.52	Mapped function code of received PZD5	0x0000–0xFFFF	0x0000
P14.53	Mapped function code of received PZD6	0x0000–0xFFFF	0x0000

Function code	Name	Description	Setting
P14.54	Mapped function code of received PZD7	0x0000–0xFFFF	0x0000
P14.55	Mapped function code of received PZD8	0x0000–0xFFFF	0x0000
P14.56	Mapped function code of received PZD9	0x0000–0xFFFF	0x0000
P14.57	Mapped function code of received PZD10	0x0000–0xFFFF	0x0000
P14.58	Mapped function code of received PZD11	0x0000–0xFFFF	0x0000
P14.59	Mapped function code of received PZD12	0x0000–0xFFFF	0x0000

Sent parameters

Function code	Name	Description
P15.13	Sent PZD2	0: Disable
P15.14	Sent PZD3	1: Running frequency (x100, Hz)
P15.15	Sent PZD4	2: Set frequency (x100, Hz)
P15.16	Sent PZD5	3: Bus voltage (x10, V)
P15.17	Sent PZD6	4: Output voltage (x1, V)
P15.18	Sent PZD7	5: Output current (x10, A)
P15.19	Sent PZD8	6: Actual output torque (x10, %)
P15.20	Sent PZD9	7: Actual output power (x10, %)
P15.21	Sent PZD10	8: Rotation speed of running (x1, RPM)
P15.22	Sent PZD11	9: Linear speed of running (x1, m/s)
P15.23	Sent PZD12	10: Ramp reference frequency
		11: Fault code
		12: AI1 input (* 100, V)
		13: AI2 input (* 100, V)
		14: AI3 input (* 100, V)

Function code	Name	Description
		15: HDIA frequency value (*100, kHz) 16: Terminal input status 17: Terminal output status 18: PID reference (x100, %) 19: PID feedback (x100, %) 20: Motor rated torque 21: High-order bit of position reference (signed) 22: Low-order bit of position reference (unsigned) 23: High-order bit of position feedback (signed) 24: Low-order bit of position feedback (unsigned) 25: Status word 26: HDIB frequency value (*100, kHz) 27: PG card pulse feedback count high-order bits 28: PG card pulse feedback count low-order bits 29: Brake status 30: Non standard state (Reserved) 31–51: Reserved 52: Temperature 53: U-phase current transient value 54: V-phase current transient value 55: W-phase current transient value 56–57: Reserved 58: Load weight 59: Current peak value 60: Filter torque setting (filter after running) 61: Mwh electromotive status (high-order bits) 62: Kwh electromotive status (low-order bits) (*10,Kwh) 63: Mwh electricity generation status (high-order bits) 64: Kwh electricity generation status (low-order bits) (*10,Kwh) 65: PG card pulse reference count high-order bits 66: PG card pulse reference count low -order bits 67: Function code mapping (PZD2 to PZD12 correspond to P14.60 to P14.70.)

For function code mapping, it must be used together with P14.48, and P14.60–P14.70.

Function code	Name	Description	Setting
P14.48	Channel selection	0x00–0x12	0x11

Function code	Name	Description	Setting
	for mapping between PZDs and function codes	Ones place: Channel for mapping function codes to PZDs 0: Reserved 1: Group P15 2: Group P16 Tens place: Save function at power failure 0: Disable 1: Enable	
P14.60	Mapped function code of sent PZD2	0x0000–0xFFFF For example, if the function code to be mapped is P94.39, set it to 0x5E27.	0x0000
P14.61	Mapped function code of sent PZD3	0x0000–0xFFFF	0x0000
P14.62	Mapped function code of sent PZD4	0x0000–0xFFFF	0x0000
P14.63	Mapped function code of sent PZD5	0x0000–0xFFFF	0x0000
P14.64	Mapped function code of sent PZD6	0x0000–0xFFFF	0x0000
P14.65	Mapped function code of sent PZD7	0x0000–0xFFFF	0x0000
P14.66	Mapped function code of sent PZD8	0x0000–0xFFFF	0x0000
P14.67	Mapped function code of sent PZD9	0x0000–0xFFFF	0x0000
P14.68	Mapped function code of sent PZD10	0x0000–0xFFFF	0x0000
P14.69	Mapped function code of sent PZD11	0x0000–0xFFFF	0x0000
P14.70	Mapped function code of sent PZD12	0x0000–0xFFFF	0x0000
P14.60	Mapped function code of sent PZD2	0x0000–0xFFFF	0x0000
P14.61	Mapped function	0x0000–0xFFFF	0x0000

Function code	Name	Description	Setting
	code of sent PZD3		
P14.62	Mapped function code of sent PZD4	0x0000–0xFFFF	0x0000
P14.63	Mapped function code of sent PZD5	0x0000–0xFFFF	0x0000
P14.64	Mapped function code of sent PZD6	0x0000–0xFFFF	0x0000
P14.65	Mapped function code of sent PZD7	0x0000–0xFFFF	0x0000
P14.66	Mapped function code of sent PZD8	0x0000–0xFFFF	0x0000
P14.67	Mapped function code of sent PZD9	0x0000–0xFFFF	0x0000
P14.68	Mapped function code of sent PZD10	0x0000–0xFFFF	0x0000

11.4 PROFINET/EtherNet IP PZD communication

Received parameters.

Function code	Name	Description
P16.32	Received PZD2	0: Disable
P16.33	Received PZD3	1: Set frequency (0–Fmax (Unit: 0.01Hz))
P16.34	Received PZD4	2: PID reference (-1000–1000, in which 1000 corresponds to 100.0%)
P16.35	Received PZD5	3: PID feedback (-1000–1000, in which 1000 corresponds to 100.0%)
P16.36	Received PZD6	4: Torque setting (-3000+3000, in which 1000 corresponds to 100.0% of the motor rated current)
P16.37	Received PZD7	5: Setting of the upper limit of forward running frequency (0–Fmax, unit: 0.01 Hz)
P16.38	Received PZD8	6: Setting of the upper limit of reverse running frequency (0–Fmax, unit: 0.01 Hz)
P16.39	Received PZD9	7: Upper limit of the electromotive torque (0–3000, in which 1000 corresponds to 100.0% of the motor rated current)
P16.40	Received PZD10	8: Upper limit of braking torque (0–3000, in which 1000
P16.41	Received PZD11	
P16.42	Received PZD12	

Function code	Name	Description
		corresponds to 100% of the motor rated current) 9: Virtual input terminal command. Range: 0x000–0x1FF (Corresponding to S12/S11/S10/S9/S8/S7/S6/S5/HDIB/HDIA/S4/S3/S2/S1 in sequence) 10: Virtual output terminal command. Range: 0x00–0x0F (Corresponding to RO2/RO1/HDO/Y1 in sequence) 11: Voltage setting (special for V/F separation) (0–1000, in which 1000 corresponds to 100% of the motor rated voltage) 12: AO1 output setting 1 (-1000+1000, in which 1000 corresponds to 100.0%) 13: AO2 output setting 2 (-1000+1000, in which 1000 corresponds to 100.0%) 14: High-order bit of position reference (signed) 15: Low-order bit of position reference (unsigned) 16: High-order bit of position feedback (signed) 17: Low-order bit of position feedback (unsigned) 18: Position feedback setting flag (position feedback can be set only after this flag is set to 1 and then to 0) 19–20: Reserved 21: Non standard frequency giving 22–25: Reserved 26: Reference encoder pulse high-order bits 27: Reference encoder pulse low-order bits 28–46: Reserved 47: ACC time (0–1000 corresponding to 0.0–100.0s) 48: DEC time (0–1000 corresponding to 0.0–100.0s) 49: Function code mapping (PZD2 to PZD12 correspond to P14.49 to P14.59.)

When encoder pulses are used, P20.15 must be used together.

Function code	Name	Description	Setting
P20.15	Speed measurement mode	3: Pulses are obtained through PROFINET communication to measure the speed.	3

When ACC/DEC time is used, P16.73 must be used together.

Function code	Name	Description	Setting
P16.73	Communication set ACC/DEC time selection	2: PROFINET communication	2

For function code mapping, it must be used together with P14.48–P14.59.

Sent parameters

Function code	Name	Description
P16.43	Sent PZD2	0: Disable
P16.44	Sent PZD3	1: Running frequency (x100, Hz)
P16.45	Sent PZD4	2: Set frequency (x100, Hz)
P16.46	Sent PZD5	3: Bus voltage (x10, V)
P16.47	Sent PZD6	4: Output voltage (x1, V)
P16.48	Sent PZD7	5: Output current (x10, A)
P16.49	Sent PZD8	6: Actual output torque (x10, %)
P16.50	Sent PZD9	7: Actual output power (x10, %)
P16.51	Sent PZD10	8: Rotation speed of running (x1, RPM)
P16.52	Sent PZD11	9: Linear speed of running (x1, m/s)
P16.53	Sent PZD12	10: Ramp reference frequency 11: Fault code 12: AI1 input (* 100, V) 13: AI2 input (* 100, V) 14: AI3 input (* 100, V) 15: HDIA frequency value (*100, kHz) 16: Terminal input status 17: Terminal output status 18: PID reference (x100, %) 19: PID feedback (x100, %) 20: Motor rated torque 21: High-order bit of position reference (signed) 22: Low-order bit of position reference (unsigned) 23: High-order bit of position feedback (signed) 24: Low-order bit of position feedback (unsigned) 25: Status word 26: HDIB frquency value (*100, kHz) 27: PG card pulse feedback count high-order bits 28: PG card pulse feedback count low-order bits 29: Brake status 30: Non standard state (Reserved)

Function code	Name	Description
		31–51: Reserved 52: Temperature 53: U-phase current transient value 54: V-phase current transient value 55: W-phase current transient value 56–57: Reserved 58: Load weight 59: Current peak value 60: Filter torque setting (filter after running) 61: MWh electromotive status (high-order bits) 62: kWh electromotive status (low-order bits) (*10, kWh) 63: MWh electricity generation status (high-order bits) 64: kWh electricity generation status (low-order bits) (*10, kWh)

For function code mapping, it must be used together with P14.48, and P14.60–P14.70.

Appendix A Expansion card

A.1 Model definition

EC-PG 5 01-05 B

- ① ② ③ ④ ⑤ ⑥

Symbol	Description	Naming example
①	Product category	EC: Expansion card
②	Card category	IC: IoT card IO: IO card PG: PG card PS: Power supply card TX: Communication card
③	Technical version	Indicates the generation of technical version by using an odd number. For example, 1, 3, 5, and 7 indicate the 1st, 2nd, 3rd and 4th generations of technical version.
④	Distinguishing code	01: Incremental PG card + frequency-divided output
		02: Sine/Cosine PG card + pulse direction setting + frequency-divided output
		03: UVW PG interface + pulse direction setting + frequency-divided output
		04: Resolver PG interface + pulse direction setting + frequency-divided output
		05: Incremental PG card + pulse direction setting + frequency-divided output
		06: Absolute PG interface + pulse direction setting + frequency-divided output
		07: simplified incremental PG card
⑤	Working power	00: Passive
		05: 5V
		12: 12-15V
		24: 24V
⑥	Expansion card version	Empty: Version A B: Version B C: Version C

EC-TX 5 01 B

① ② ③ ④ ⑤

Symbol	Description	Naming example
①	Product category	EC: Expansion card
②	Card category	TX: communication expansion card
③	Technical version	Indicates the generation of technical version by using an odd number. For example, 1, 3, 5, and 7 indicate the 1st, 2nd, 3rd and 4th generations of technical version.
④	Distinguishing code	01: Bluetooth communication card
		02: WIFI communication card
		03: PROFIBUS communication card
		04: Ethernet communication card
		05: CANopen communication card
		06: DeviceNet communication card
		07: BACnet communication card
		08: EtherCAT communication card
		09: PROFINET communication card
		10: EtherNet/IP communication card
		11: CAN master/slave control communication card
15: Modbus TCP communication card		
⑤	Expansion card version	Empty: Version A B: Version B C: Version C

EC-IO 5 01-00

① ② ③ ④ ⑤

Symbol	Description	Naming example
①	Product category	EC: Expansion card
②	Card category	IO: I/O expansion card
③	Technical version	Indicates the generation of technical version by using an odd number. For example, 1, 3, 5, and 7 indicate the 1st, 2nd, 3rd and 4th generations of technical version.

Symbol	Description	Naming example
④	Distinguishing code	01: Multiple-function I/O expansion card (4 digital inputs, 1 digital output, 1 analog input, 1 analog output, and 2 relay outputs)
		02: Digital I/O expansion card (4 digital inputs, 2 relay outputs, 1 PT100, and 1 PT1000)
		03: Analog I/O card
		04: Reserved 1
		05: Reserved 2
⑤	Special requirement	

EC-IC 5 02-2

- ① ② ③ ④ ⑤

Field	Field description	Naming example
①	Product category	EC: Expansion card
②	Card category	IC: IoT card IO: IO card PC: Programmable card PG: PG card PS: Power supply card TX: Communication card
③	Technical version	Indicates the generation of technical version by using an odd number. For example, 1, 3, 5, and 7 indicate the 1st, 2nd, 3rd and 4th generations of technical version.
④	Distinguishing code	01: GPRS card
		02: 4G card
⑤	Antenna type	1: Internal
		2: External

EC-PS 5 01-24

- ① ② ③ ④ ⑤

Field	Field description	Naming example
①	Product category	EC: Expansion card
②	Card category	IC: IoT card IO: IO card PC: Programmable card PG: PG card PS: Power supply card TX: Communication card
③	Technical version	Indicates the generation of technical version by using an odd number. For example, 1, 3, 5, and 7 indicate the 1st, 2nd, 3rd and 4th generations of technical version.
④	Distinguishing code	01: Powering the control board and keypad
⑤	Working power	24: DC 24V

The following table lists expansion cards that the VFD supports. The expansion cards are optional and need to be purchased separately.

Name	Model	Specifications
I/O expansion card 1	EC-IO501-00	<ul style="list-style-type: none"> ●4 digital inputs ●1 digital output ●1 analog input ●1 analog output ● 2 relay outputs: 1 double-contact output, and 1 single-contact output.
I/O expansion card 2	EC-IO502-00	<ul style="list-style-type: none"> ●4 digital inputs ●1 PT100 ●1 PT1000 ●2 relay outputs: single-contact NO outputs <p>Note: The expansion card has been built into the 7.5kW and higher VFD models but it is optional for the VFD models of lower than 7.5kW. For details, see section 4.4.3 Control circuit</p>

Name	Model	Specifications
		wiring of I/O expansion card 2.
Bluetooth communication card	EC-TX501-1/ EC- TX501-2	<ul style="list-style-type: none"> ●Supporting Bluetooth 4.0 ●With INVT mobile app, you can set the parameters and monitor the states of the VFD through Bluetooth ● The maximum communication distance in open environments is 30 m. ●EC-TX501-1 is equipped with a built-in antenna and applicable to molded case machines. ●EC-TX501-2 is configured with an external sucker antenna and applicable to sheet metal machines.
WIFI communication card	EC-TX502-2/ EC- TX502-2	<ul style="list-style-type: none"> ●Meeting IEEE802.11b/g/n ●With INVT mobile app, you can monitor the VFD locally or remotely through WIFI communication ● The maximum communication distance in open environments is 30 m. ●EC-TX502-1 is equipped with a built-in antenna and applicable to molded case machines. ●EC-TX502-2 is configured with an external sucker antenna and applicable to sheet metal machines.
PROFIBUS-DP communication card	EC-TX503	<ul style="list-style-type: none"> ●Supporting the PROFIBUS-DP protocol
Ethernet communication card	EC-TX504	<ul style="list-style-type: none"> ●Supporting Ethernet communication with INVT internal protocol ●Can be used in combination with INVT upper computer monitoring software INVT Workshop
CANopen communication card	EC-TX505	<ul style="list-style-type: none"> ●Based on the CAN2.0A physical layer ●Supporting the CANopen protocol
PROFINET communication card	EC-TX509	<ul style="list-style-type: none"> ●Supporting the PROFINET protocol
EtherNet IP communication card	EC-TX510	<ul style="list-style-type: none"> ●Supporting the EtherNet IP protocol ●Providing two EtherNet IP ports, supporting 10/100M full/half duplex operating
CAN master/slave control	EC-TX511	<ul style="list-style-type: none"> ●Based on the CAN2.0B physical layer ●Adopting INVT proprietary master/slave control protocol

Name	Model	Specifications
communication card		
CAN-NET two-in-one communication card	EC-TX511B	<ul style="list-style-type: none"> ●Supporting Ethernet communication with INVT internal protocol ●Can be used in combination with INVT upper computer monitoring software INVT Workshop ●Based on the CAN2.0A physical layer ●Supporting the CANopen protocol
216 communication card	EC-TX513	<ul style="list-style-type: none"> ●Supporting the 216 communication protocol
Modbus TCP communication card	EC-TX515	<ul style="list-style-type: none"> ●Supporting the Modbus TCP protocol and supporting Modbus TCP slaves ●Providing two Modbus TCP ports, supporting 10/100M full/half duplex operating
Sin/Cos PG card	EC-PG502	<ul style="list-style-type: none"> ●Applicable to Sin/Cos encoders with or without CD signals ●Supporting A, B, Z frequency-divided output ●Supporting pulse string reference input
Incremental PG card with UVW	EC-PG503-05	<ul style="list-style-type: none"> ●Applicable to differential encoders of 5 V ●Supporting the orthogonal input of A, B, and Z ●Supporting pulse input of phases U, V, and W ●Supporting frequency-divided output of A, B, and Z ●Supporting the input of pulse string reference
Resolver PG card	EC-PG504-00	<ul style="list-style-type: none"> ●Applicable to resolver encoders ●Supporting frequency-divided output of resolver-simulated A, B, Z ●Supporting the input of pulse string reference
Multi-function incremental PG card	EC-PG505-12	<ul style="list-style-type: none"> ●Applicable to OC encoders of 5V or 12V ●Applicable to push-pull encoders of 5V or 12V ●Applicable to differential encoders of 5V ●Supporting the orthogonal input of A, B, and Z ●Supporting the frequency-divided output of A, B, and Z ●Supporting the input of pulse string reference
Simplified incremental PG card	EC-PG507-12	<ul style="list-style-type: none"> ●Applicable to OC encoders of 5V or 12V ●Applicable to push-pull encoders of 5V or 12V ●Applicable to differential encoders of 5V
24V simplified incremental PG	EC-PG507-24	<ul style="list-style-type: none"> ●Applicable to 24V OC encoders ●Applicable to 24V push-pull encoders

Name	Model	Specifications
card		<ul style="list-style-type: none"> •Applicable to 24V differential encoders
4G card	EC-IC502-2	<ul style="list-style-type: none"> •Supporting standard RS485 interfaces •Supporting 4G communication
24V power supply card	EC-PS501-24	<ul style="list-style-type: none"> •Input voltage range: DC18–30V (Rated 24Vdc)/2A •Three channels of output voltage: +5V/1A (±5%), +15V/0.2A (±10%), -15V/0.2A (±10%)



I/O expansion card 1
EC-IO501-00



I/O expansion card 2
EC-IO502-00



Bluetooth/WIFI
communication card
EC-TX501/502



PROFIBUS-DP
communication card
EC-TX503



Ethernet
communication card
EC-TX504



CANopen/CAN
master/slave control
communication card
EC-TX505/511



PROFINET
communication card
EC-TX509

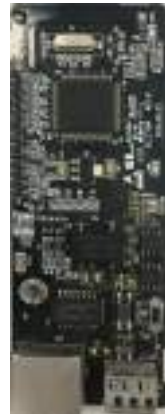

CAN-NET two-in-one
communication card
EC-TX511B



216 communication card
EC-TX513



EtherNet IP/Modbus
TCP communication card
EC-TX510/515



Sin/Cos PG card
EC-PG502



UVW incremental PG card
EC-PG503-05



Resolver PG card
EC-PG504-00



Multifunction
incremental PG card
EC-PG505-12



Simplified incremental
PG card
EC-PG507-12



24V simplified
incremental PG card
EC-PG507-24



4G card
EC-IC502-2



24V power supply card
EC-PS501-24

A.2 Dimensions and installation

All expansion cards are of the same dimensions (108x39mm) and can be installed in the same way.

Comply with the following rules when installing or removing an expansion card:

- Ensure that no power is applied before installing the expansion card.
- The expansion card can be installed into any of the card slots SLOT1, SLOT2, and SLOT3.
- The 5.5 kW and lower VFD models can be configured with two expansion cards at the same time, and the 7.5 kW and higher VFD models can be configured with three expansion cards.
- If interference occurs on the external wires after expansion cards are installed, change their installation card slots flexibly to facilitate the wiring. For example, the connector of the connection cable of the DP card is large, so it is recommended to be installed in the SLOT1 card slot.
- To ensure high anti-interference capability in closed-loop control, you need to use a shielding wire in the encoder cable and ground the two ends of the shielding wire, that is, connect the shielding layer to the housing of the motor on the motor side, and connect the shielding layer to the PE terminal on the PG card side.

The following figure shows the installation diagram and the VFD with expansion cards installed.

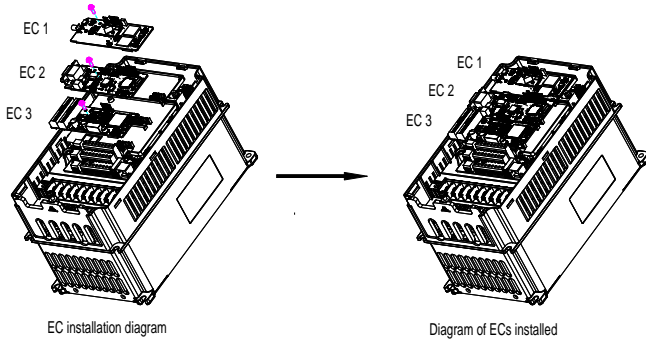

Figure A-1 7.5 kW and higher VFD models with expansion cards installed

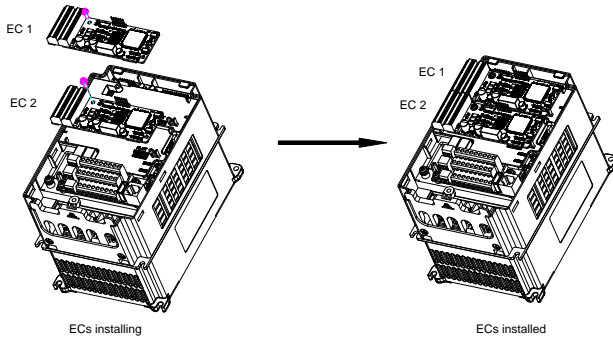

Figure A-2 5.5 kW and lower VFD models with expansion cards installed

Expansion card installation procedure:

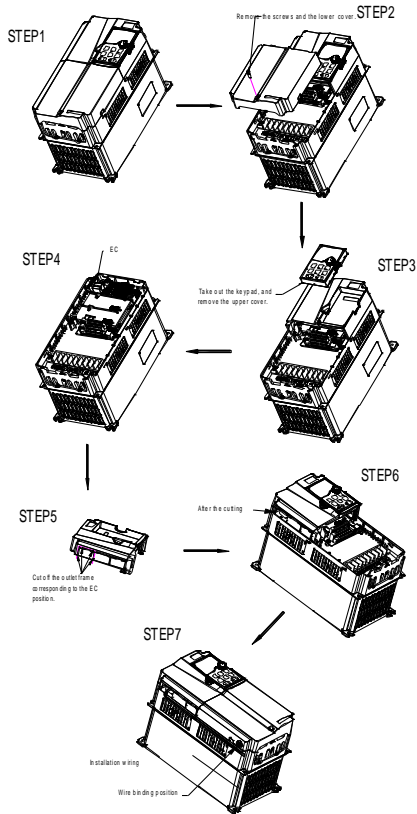

Figure A-3 Expansion card installation procedure

A.3 Wiring

Ground a shielded cable as follows:

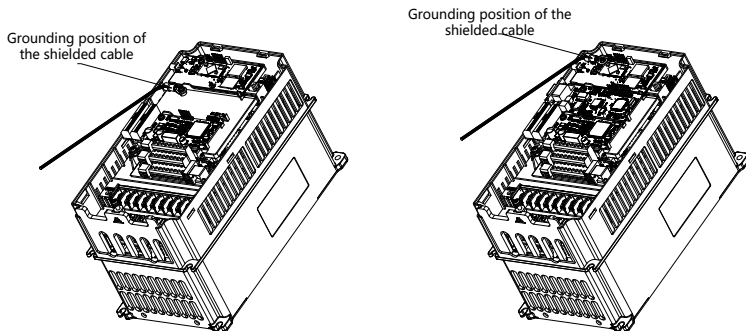
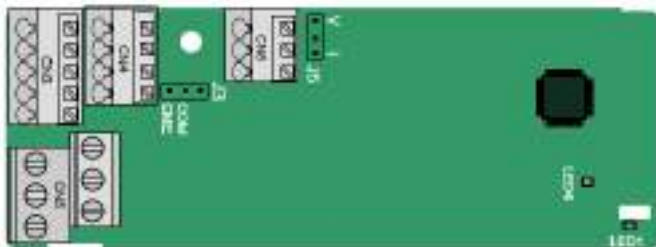

Figure A-4 Expansion card grounding diagram

A.4 I/O expansion card 1 (EC-IO501-00)



The terminals are arranged as follows:

CME and COM are shorted through J3 before delivery, and J5 is the jumper for selecting the output type (voltage or current) of AO2.

AI3	AO2	GND
-----	-----	-----

COM	CME	Y2	S5	
PW	+24V	S6	S7	S8

RO3A	RO3B	RO3C
RO4A		RO4C

Indicator definition:

Indicator	Definition	Function
LED1	Status indicator	This indicator is on when the expansion card is establishing a connection with the control board; it blinks periodically after the expansion card is properly connected to the control board (the period is 1s, on for 0.5s, and off for the other 0.5s); and it is off when the expansion card is disconnected from the control board.
LED4	Power indicator	This indicator is on after the I/O expansion card is powered on by the control board.

EC-IO501-00 can be used in scenarios where the I/O interfaces of VFD cannot meet the application requirements. It can provide 4 digital inputs, 1 digital output, 1 analog input, 1 analog output, and two relay outputs. It is user-friendly, providing relay outputs through European-style screw terminals and other inputs and outputs through spring terminals.

EC-IO501-00 terminal functions:

Category	Symbol	Terminal	Description
Power supply	PW	External power	Used to provide input digital working power from the external to the internal Voltage range: 12–30V PW and +24V have been short connected before delivery.
Analog input/output	AI3—GND	Analog input 1	<ol style="list-style-type: none"> Input range: For AI3, 0–10V or 0–20mA Input impedance: 20kΩ for voltage input or 250Ω for current input Set it to be voltage or current input through the corresponding function code. Resolution: 5mV when 10V corresponds to 50Hz Deviation: ±0.5%; input of 5V or 10mA or higher at the temperature of 25°C
	AO2—GND	Analog output 1	<ol style="list-style-type: none"> Output range: 0–10V or 0–20mA Whether it is voltage or current output can be set through J5. Deviation: ±0.5%; input of 5 V or 10 mA or higher at the temperature of 25°C
Digital input/output	S5—COM	Digital input 1	<ol style="list-style-type: none"> Internal impedance: 6.6kΩ Allowed voltage input of 12–30V Bidirectional input terminal Max. input frequency: 1kHz
	S6—COM	Digital input 2	
	S7—COM	Digital input 3	
	S8—COM	Digital input 4	
	Y2—CME	Digital output	<ol style="list-style-type: none"> Switch capacity: 50mA/30V Output frequency range: 0–1kHz The terminals CME and COM are short connected through J3 before delivery.
Relay output	RO3A	NO contact of relay 3	<ol style="list-style-type: none"> Contact capacity: 3A/AC250V, 1A/DC30V Do not use them as high-frequency digital outputs.
	RO3B	NC contact of relay 3	
	RO3C	Common contact of relay 3	
	RO4A	NO contact of relay 4	

Category	Symbol	Terminal	Description
	RO4C	Common contact of relay 4	

A.5 Communication cards

A.5.1 Bluetooth communication card (EC-TX501) and WIFI communication card (EC-TX502)



Definition of indicators and function keys:

Indicator	Definition	Function
LED1/LED3	Bluetooth/WIFI status indicator	This indicator is on when the expansion card is establishing a connection with the control board; it blinks periodically after the expansion card is properly connected to the control board (the period is 1s, on for 0.5s, and off for the other 0.5s); and it is off when the expansion card is disconnected from the control board.
LED2	Bluetooth communication status indicator	This indicator is on when the communication card is online and data exchange can be performed. It is off when the Bluetooth communication card is not in the online state.
LED5	Power indicator	It is off when Bluetooth communication is not in the online state.
SW1	WIFI factory reset button	It is restored to default values and returned to the local monitoring mode.
SW2	WIFI hardware reset button	It is used to reboot the expansion card.

The wireless communication card is especially useful for scenarios where you cannot directly use the keypad to operate the VFD due to the restriction of the installation space. With a mobile phone APP, you can operate the VFD in a maximum distance of 30 m. You can choose a PCB antenna or an external sucker antenna. If the VFD is located in an open space and is a molded case machine, you can use a built-in PCB antenna; and if it is a sheetmetal machine and located in a metal cabinet, you need to use an external sucker antenna.

When installing a sucker antenna, install a wireless communication card on the VFD first, and then

lead the SMA connector of the sucker antenna into the VFD and screw it to CN2, as shown in the following figure. Place the antenna base on the chassis and expose the upper part. Try to keep it unblocked.

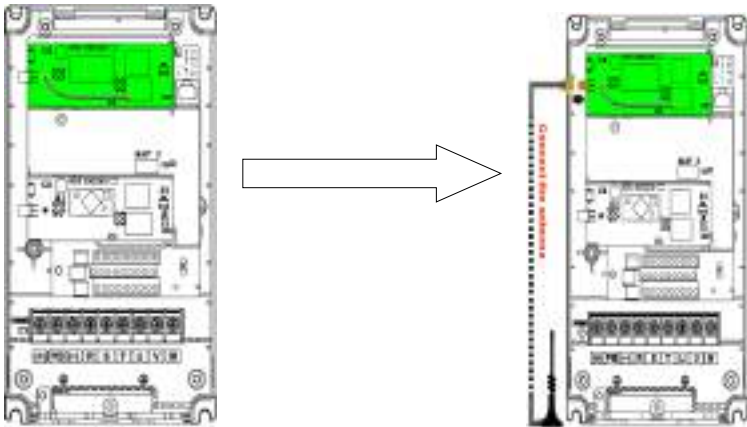

The wireless communication card must be used with the INVT VFD APP. Scan the QR code of the VFD nameplate to download it. For details, refer to the wireless communication card manual provided with the expansion card. The main interface is shown as follows.

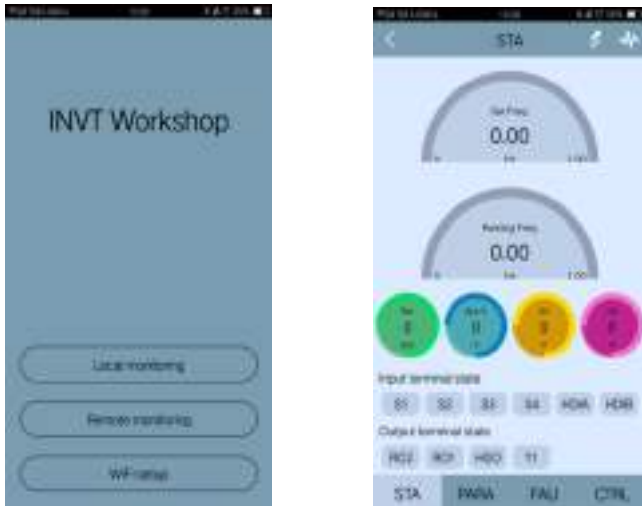

A.5.2 PROFIBUS-DP communication card (EC-TX503)



CN1 is a 9-pin D-type connector, as shown in the following figure.

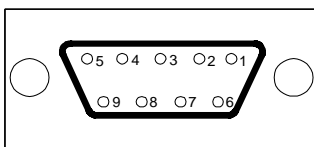

Connector pin		Description
1	-	Unused
2	-	Unused
3	B-Line	Data+ (twisted pair 1)
4	RTS	Request sending
5	GND_BUS	Isolation ground
6	+5V BUS	Isolated power supply of 5 V DC
7	-	Unused
8	A-Line	Data- (twisted pair 2)
9	-	Unused
Housing	SHLD	PROFIBUS cable shielded cable

+5V and GND_BUS are bus terminators. Some devices, such as the optical transceiver (RS485), may need to obtain power through these pins.

Some devices use RTS to determine the sending and receiving directions. In normal applications, only A-Line, B-Line, and the shield layer need to be used.

Indicator definition:

Indicator	Definition	Function
LED1	Status indicator	This indicator is on when the expansion card is establishing a connection with the control board; it blinks periodically after the expansion card is properly connected to the control board (the period is 1s, on for 0.5s, and off for the other 0.5s);

Indicator	Definition	Function
		and it is off when the expansion card is disconnected from the control board.
LED2	Online indicator	This indicator is on when the communication card is online and data exchange can be performed. It is off when the communication card is not in the online state.
LED3	Offline/Fault indicator	<p>This indicator is on when the communication card is offline and data exchange cannot be performed. It blinks when the communication card is not in the offline state.</p> <p>It blinks at the frequency of 1 Hz when a configuration error occurs: The length of the user parameter data set during the initialization of the communication card is different from that during the network configuration.</p> <p>It blinks at the frequency of 2 Hz when user parameter data is incorrect: The length or content of the user parameter data set during the initialization of the communication card is different from that during the network configuration.</p> <p>It blinks at the frequency of 4 Hz when an error occurs in the ASIC initialization of PROFIBUS communication.</p> <p>It is off when the diagnosis function is disabled.</p>
LED4	Power indicator	This indicator is on after the control board feeds power to the communication card.

For details, see the *Goodrive350 Series VFD Communication Expansion Card Operation Manual*.

A.5.3 Ethernet communication card (EC-TX504)

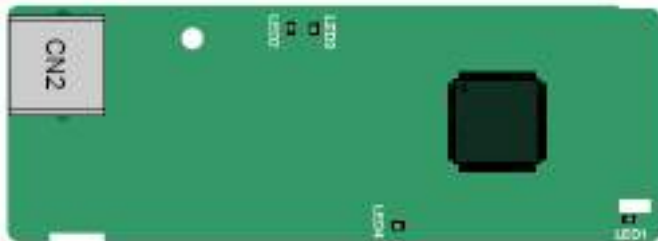

The EC-TX504 communication card adopts standard RJ45 terminals.

Indicator definition:

Indicator	Definition	Function
LED1	Status indicator	This indicator is on when the expansion card is establishing a connection with the control board; it blinks periodically after the expansion card is properly connected to the control board (the period is 1s, on for 0.5s, and off for the other 0.5s); and it is off when the expansion card is disconnected from the control board.
LED2	Network connection status indicator	This indicator is on when the physical connection to the upper computer is normal; it is off when the upper computer is disconnected.
LED3	Network communication status indicator	This indicator is on when there is data exchange with the upper computer; it blinks when there is no data exchange with the upper computer.
LED4	Power indicator	This indicator is on after the control board feeds power to the communication card.

A.5.4 CANopen communication card (EC-TX505) and CAN master/slave control communication card (EC-TX511)

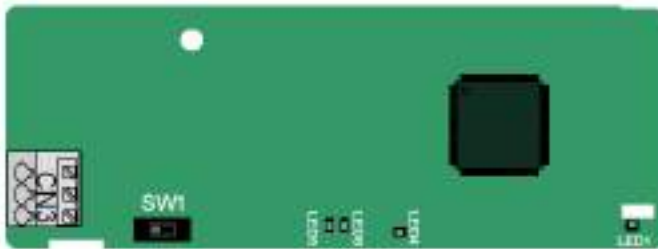

The EC-TX505/511 communication card is user-friendly, adopting spring terminals.

3-Pin spring terminal	Pin	Function	Description
	1	CANH	CANopen bus high level signal
	2	CANG	CANopen bus shielding
	3	CANL	CANopen bus low level signal

Terminal resistor switch function description:

Terminal resistor switch	Position value	Function	Description
	Left	OFF	CAN_H and CAN_L are not connected to a terminal resistor.
	Right	ON	CAN_H and CAN_L are connected to a terminal resistor of 120 Ω.

Indicator definition:

Indicator	Definition	Function
LED1	Status indicator	This indicator is on when the expansion card is establishing a connection with the control board; it blinks periodically after the expansion card is properly connected to the control board (the period is 1s, on for 0.5s, and off for the other 0.5s); and it is off when the expansion card is disconnected from the control board.
LED4	Power indicator	This indicator is on after the control board feeds power to the communication card.
LED5	Run indicator	This indicator is on when the communication card is in the working state. It is off when a fault occurs. Check whether the reset pin of the communication card and the power supply are properly connected. It blinks when the communication card is in the pre-operation state. It blinks once when the communication card is in the stopped state.
LED6	Error indicator	This indicator is on when the CAN controller bus is off or a fault occurs on the VFD. It is off when the communication card is in the working state. It blinks when the address setting is incorrect. It blinks once when a received frame is missed or an error occurs during frame receiving.

For details, see the *Goodrive350 Series VFD Communication Expansion Card Operation Manual*.

A.5.5 PROFINET communication card (EC-TX509)

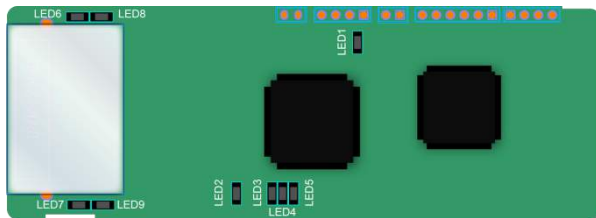

The terminal CN2 adopts standard RJ45 interfaces, which are in the dual design, and the two RJ45 interfaces are not distinguished from each other and can be interchangeably inserted. They are arranged as follows:

Pin	Name	Description
1	TX+	Transmit Data+
2	TX-	Transmit Data-
3	RX+	Receive Data+
4	n/c	Not connected
5	n/c	Not connected
6	RX-	Receive Data-
7	n/c	Not connected
8	n/c	Not connected

Indicator definition:

The PROFINET communication card has 9 indicators, of which LED1 is the power indicator, LED2–5 are the communication state indicators of the communication card, and LED6–9 are the state indicators of the network port.

LED	Color	Status	Description
LED1	Green		3.3V power indicator
LED2 (Bus status indicator)	Red	On	No network connection
		Blinking	The connection to the network cable between the PROFINET controller is OK, but the communication is not established.
		Off	Communication with the PROFINET controller has been established.
LED3 (System fault indicator)	Green	On	PROFINET diagnosis exists.
		Off	No PROFINET diagnosis.
LED4 (Slave ready indicator)	Green	On	TPS-1 protocol stack has started.
		Blinking	TPS-1 waits for MCU initialization.
		Off	TPS-1 protocol stack does not start.
LED5	Green		Manufacturer-specific, depending on the

LED	Color	Status	Description
(Maintenance status indicator)			characteristics of the device
LED6/7 (Network port status indicator)	Green	On	PROFINET communication card and PC/PLC have been connected with a network cable.
		Off	PROFINET communication card and PC/PLC have not been connected yet.
LED8/9 (Network port communication indicator)	Green	On	PROFINET communication card and PC/PLC are communicating.
		Off	PROFINET communication card and PC/PLC are not yet communicating.

Electrical connection:

The PROFINET communication card adopts standard RJ45 interfaces, which can be used in a linear network topology and a star network topology. The linear network topology electrical connection diagram is shown in the following.

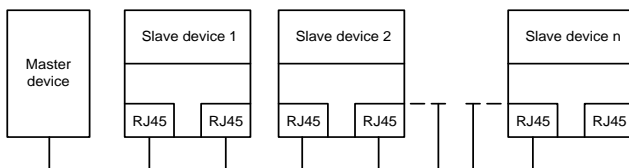
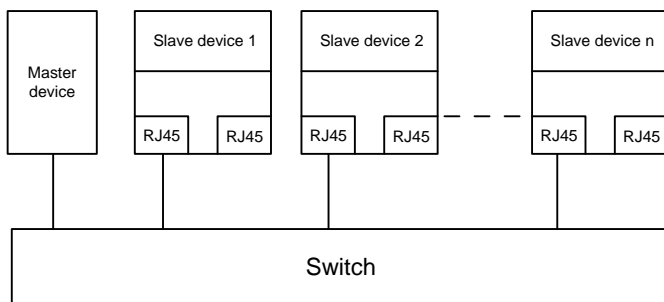

Figure A-5 Linear network topology electrical connection diagram

Note: For the star network topology, you need to prepare PROFINET switches.

The star network topology electrical connection diagram is shown as follows.



A.5.6 EtherNet/IP communication card (EC-TX510)



The EC-TX510 communication card adopts standard dual RJ45 interfaces, and the two RJ45 interfaces are not distinguished from each other and can be interchangeably inserted.



Interface functions

Pin	Name	Description
1	TX+	Transmit Data+
2	TX-	Transmit Data-
3	RX+	Receive Data+
4	n/c	Not connected
5	n/c	Not connected
6	RX-	Receive Data-
7	n/c	Not connected
8	n/c	Not connected

The EtherNet/IP communication card provides four LED indicators and four net port indicators to indicate its states.

LED	Color	State	Description
LED1	Green	On	The card is shaking hands with the VFD.
		Blinking (1Hz)	The card and VFD communicate normally.
		Off	The card and VFD communicate improperly.
LED2 (Fieldbus status indicator)	Green	On	The communication between the card and PLC is online and data interchange is allowed.
		Blinking (1Hz)	IP address conflict between the card and PLC.
		Off	The communication between the card and PLC is offline.
LED3 (System fault indicator)	Red	On	Failed to set up I/O between the card and PLC.
		Blinking (1Hz)	Incorrect PLC configuration.
		Blinking (2Hz)	The card failed to send data to the PLC.

LED	Color	State	Description
		Blinking (4Hz)	The connection between the card and PLC timed out.
		Off	No fault.
LED4	Red	On	3.3V power indicator.
Net port indicator	Yellow	On	Link indicator, indicating successful Ethernet connection.
		Off	Link indicator, indicating Ethernet connection not established.
Net port indicator	Green	On	ACK indicator, indicating data interchange being performed.
		Off	ACK indicator, indicating data interchange not be performed.

For details, see the *Goodrive350 Series VFD Communication Expansion Card Operation Manual*.

A.5.7 CAN-NET two-in-one communication card (EC-TX511B)

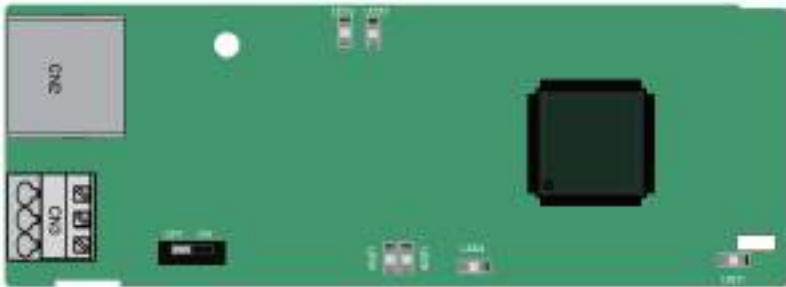

EC-TX511B uses spring-type terminals, which are easy to use. CN2 uses standard RJ45 terminals.

CN3 terminal definition

3-Pin spring terminal	Pin	Function	Description
	1	CANH	CANopen bus high level signal
	2	CANG	CANopen bus shielding
	3	CANL	CANopen bus low level signal

Terminal resistor switch function description

Terminal resistor switch	Position value	Function	Description
	Left	OFF	CAN_H and CAN_L are not connected to a terminal resistor.
	Right	ON	CAN_H and CAN_L are connected to a terminal resistor of 120 Ω.

Indicator definition:

Indicator	Definition	Function
LED1	Status indicator	This indicator is on when the expansion card is establishing a connection with the control board; it blinks periodically after the expansion card is properly connected to the control board (the period is 1s, on for 0.5s, and off for the other 0.5s); and it is off when the expansion card is disconnected from the control board.
LED2	Network connection status indicator	This indicator is on when the physical connection to the upper computer is normal; it is off when the upper computer is disconnected.
LED3	Network communication status indicator	This indicator is on when there is data exchange with the upper computer; it blinks when there is no data exchange with the upper computer.
LED4	Power indicator	This indicator is on after the control board feeds power to the card.
LED5	Run indicator	This indicator is on when the card is in running state. It is off when the card suffers a fault. Please check the connection by resetting the pins and power supply. It blinks at a specific interval when the card is in pre-run state. It blinks once when the card is in the stopped state.
LED6	Error indicator	This indicator is on when the CAN controller bus is off or a fault occurs on the VFD. It is off when the card is in the working state. It blinks at a specific interval when the address is incorrect. It blinks once when a received frame is missed or an error occurs during frame receiving.

For details, see the *Goodrive350-19 Series VFD Communication Expansion Card Operation Manual*.

A.5.8 216 communication card (EC-TX513)

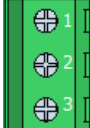

The EC-TX513 communication card uses European-style screw terminals.

3-pin European-style screw terminal	Pin	Function	Description
	1	E+	216 bus high level signal
	2	E-	216 bus low level signal
	3	PE	216 bus shielding

Terminal resistor switch function description

Terminal resistor switch	Position	Function	Description
	Up	OFF	E+ and E- are not connected to a terminal resistor.
	Down	ON	E+ and E- are connected to a terminal resistor of 120Ω.

Indicator definition

Indicator	Definition	Function
LED1	216 communication fault indicator	Used to indicate the communication status between the card and external bus (such as PLC). • Steady on: 216 communication disconnected • Steady off: Normal 216 communication • Blinking: Packet loss in 216 communication
LED2	Internal communication fault indicator	Used to indicate the internal SPI communication status between the communication card and main control board. • Steady on: Internal SPI communication disconnected • Steady off: Normal internal SPI communication • Blinking: Packet loss in internal SPI communication
LED3	Power indicator	On: The control board feeds power to the communication card.

Indicator	Definition	Function
LED4	Status indicator	<ul style="list-style-type: none"> • On: The communication card has established communication with the main control board. • Off: The communication card has not established communication with the main control board.

For details, see the *Goodrive350-19 Series VFD Communication Expansion Card Operation Manual*.

A.5.9 Modbus TCP communication card (EC-TX515)

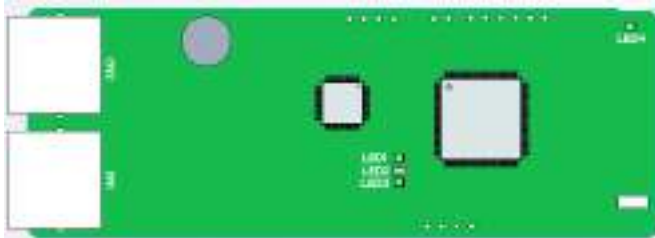

The EC-TX515 communication card adopts standard dual RJ45 interfaces, and the two RJ45 interfaces are not distinguished from each other and can be interchangeably inserted.



Interface functions

Pin	Name	Description
1	TX+	Transmit Data+
2	TX-	Transmit Data-
3	RX+	Receive Data+
4	n/c	Not connected
5	n/c	Not connected
6	RX-	Receive Data-
7	n/c	Not connected
8	n/c	Not connected

Indicator definition

The EC-TX515 communication card provides four LED indicators and four net port indicators to indicate its states.

LED	Color	State	Description
LED1	Green	On	The card is shaking hands with the VFD.
		Blinking (1Hz)	The card and VFD communicate normally.
		Off	The card and VFD communicate improperly.

LED	Color	State	Description
LED2 (Bus status indicator)	Green	On	The communication between the card and PLC is online and data interchange is allowed.
		Blinking (1Hz)	IP address conflict between the card and PLC.
		Off	The communication between the card and PLC is offline.
LED3 (System fault indicator)	Red	On	The card has not received valid data.
		Blinking (1Hz)	Packet function code not used or not defined.
		Blinking (8Hz)	Incorrect packet address.
		Off	No fault.
LED4	Red	On	3.3V power indicator.
Net port indicator	Yellow	On	Link indicator, indicating successful Ethernet connection.
		Off	Link indicator, indicating Ethernet connection not established.
Net port indicator	Green	On	ACK indicator, indicating data interchange being performed.
		Off	ACK indicator, indicating data interchange not be performed.

For details, see the *Goodrive350 Series VFD Communication Expansion Card Operation Manual*.

A.6 PG cards

A.6.1 Sin/Cos PG card (EC-PG502)

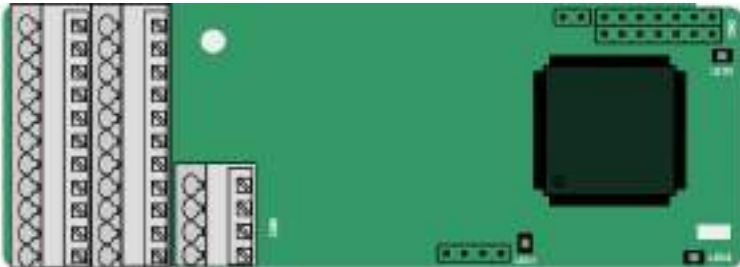

The terminals are arranged as follows:

							C1+	C1-	D1+	D1-
PE	AO+	BO+	ZO+	A1+	B1+	R1+	A2+	B2+	Z2+	PWR
GND	AO-	BO-	ZO-	A1-	B1-	R1-	A2-	B2-	Z2-	GND

Indicator definition:

Indicator	Definition	Function
LED1	Disconnection indicator	This indicator is off when A1 and B1 of the encoder are disconnected; it blinks when C1 and D1 of the encoder are disconnected; and it is on when the encoder signals are normal.
LED2	Power indicator	This indicator is on after the control board feeds power to the PG card.
LED3	Status indicator	This indicator is on when the card is establishing a connection with the control board; it blinks periodically after the expansion card is properly connected to the control board (the period is 1s, on for 0.5s, and off for the other 0.5s);and it is off when the expansion card is disconnected from the control board.

EC-PG502 terminal function description:

Signal	Port	Description
PE	Grounding terminal	Connected to the ground to enhance anti-interference performance.
PWR	Encoder power	Voltage: 5V ± 5% Max. output current: 150mA
GND		
A1+	Encoder interface	1. Supporting sine/cosine encoders (with CD signal or without CD signal) 2. SINA/SINB/SINC/SIND 0.6–1.2Vpp; SINR 0.2–0.85Vpp 3. A/B signal frequency response up to 200kHz, C/D signal frequency response up to 1kHz
A1-		
B1+		
B1-		
R1+		
R1-		
C1+		
C1-		
D1+		
D1-		
A2+	Pulse setting	1. Supporting 5V differential signal 2. Response frequency: 200 kHz
A2-		
B2+		
B2-		
Z2+		
Z2-		
AO+	Frequency-divided output	1. Differential output, compatible with 5V differential output 2. Supporting frequency division of 2 ^N , which can be set through P20.16 or P24.16; Max. output frequency: 200 kHz
AO-		
BO+		
BO-		
ZO+		
ZO-		

The following figure shows the external wiring of the PG card when it is used in combination with an encoder without CD signals.

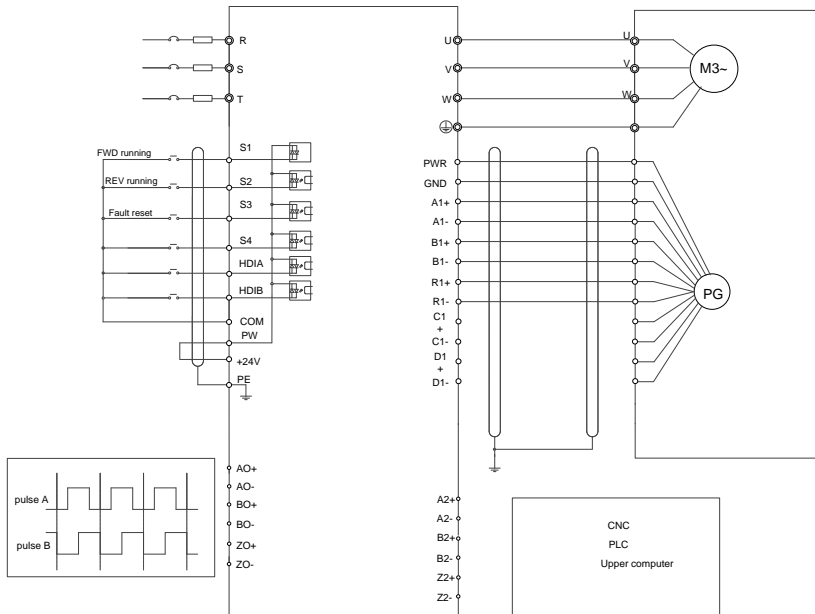

The following figure shows the external wiring of the PG card when it is used in combination with an encoder with CD signals.

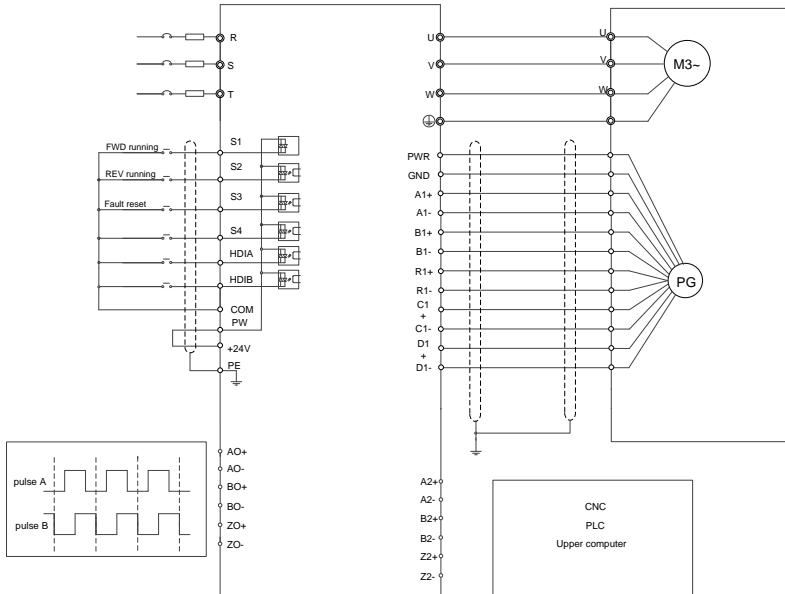

A.6.2 UVW incremental PG card (EC-PG503-05)

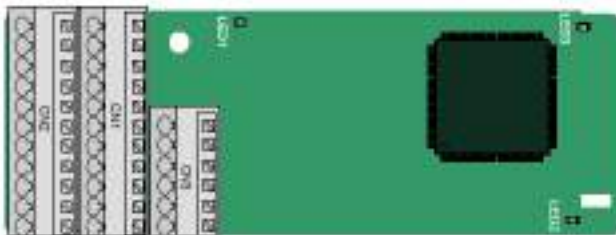

The terminals are arranged as follows:

					A2+	A2-	B2+	B2-	Z2+	Z2-
PE	AO+	BO+	ZO+	A1+	B1+	Z1+	U+	V+	W+	PWR
GND	AO-	BO-	ZO-	A1-	B1-	Z1-	U-	V-	W-	PGND

Indicator definition:

Indicator	Definition	Function
LED1	Disconnection indicator	This indicator is off only when A1 or B1 signal is disconnected during encoder rotating; and it is on in other cases.
LED2	Status indicator	This indicator is on when the card is establishing a connection with the control board; it blinks periodically after the card is properly

Indicator	Definition	Function
		connected to the control board (the period is 1s, on for 0.5s, and off for the other 0.5s); and it is off when the card is disconnected from the control board.
LED3	Power indicator	This indicator is on after the control board feeds power to the card.

EC-PG503-05 supports the input of absolute position signals and integrates the advantages of absolute and incremental encoders. It is user-friendly, adopting spring terminals.

EC-PG503-05 terminals are described as follows:

Signal	Port	Description
PE	Grounding terminal	Connected to the ground to enhance anti-interference performance.
GND	Ground	Ground of the PCB internal power.
PWR	Encoder power	Voltage: 5 V±5% Max. current: 200 mA (PGND is the isolation power ground.)
PGND		
A1+	Encoder interface	1. Differential incremental PG interface of 5V 2. Response frequency: 400kHz
A1-		
B1+		
B1-		
Z1+		
Z1-		
A2+	Pulse setting	1. Differential input of 5V 2. Response frequency: 200kHz
A2-		
B2+		
B2-		
Z2+		
Z2-		
AO+	Frequency-divided output	1. Differential output of 5V 2. Supporting frequency division of 1–255, which can be set through P20.16 or P24.16
AO-		
BO+		
BO-		
ZO+		
ZO-		
U+	UVW encoder interface	1. Absolute position (UVW information) of the hybrid encoder, differential input of 5V 2. Response frequency: 40kHz
U-		
V+		
V-		
W+		
W-		

Signal	Port	Description
W-		

The following figure shows the external wiring when EC-PG503-05 is used.

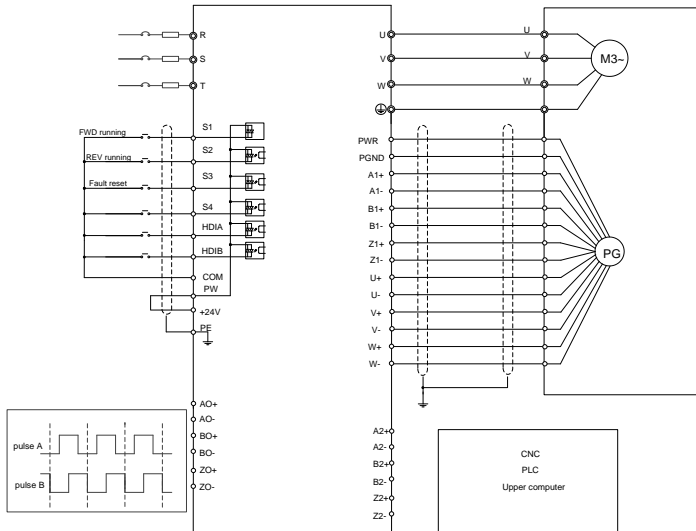

A.6.3 Resolver PG card (EC-PG504-00)



PE	AO+	BO+	ZO+	EX+	SI+	CO+	A2+	B2+	Z2+	PWR
GND	AO-	BO-	ZO-	EX-	SI-	CO-	A2-	B2-	Z2-	GND

Indicator definition:

Indicator	Definition	Function
LED1	Status indicator	This indicator is on when the card is establishing a connection with the control board; it blinks periodically after the card is properly connected to the control board (the period is 1s, on for 0.5s, and off for the other 0.5s); and it is off when the card is disconnected

Indicator	Definition	Function
		from the control board.
LED2	Disconnection indicator	This indicator is off when the encoder is disconnected; it is on when the encoder signals are normal; and it blinks when the encoder signals are not stable.
LED3	Power indicator	This indicator is on after the control board feeds power to the card.

EC-PG504-00 can be used in combination with a resolver of excitation voltage 7 Vrms. It is user-friendly, adopting spring cage terminals.

EC-PG504-00 terminal functions:

Signal	Port	Description
PE	Grounding terminal	Connected to the ground to enhance anti-interference performance.
PWR	Output power	Voltage: 5V±5%
GND		
SI+	Encoder signal input	Recommended resolver transformation ratio: 0.5
SI-		
CO+		
CO-		
EX+	Encoder excitation signal	1. Factory setting of excitation: 10kHz 2. Supporting resolvers with an excitation voltage of 7Vrms
EX-		
A2+	Pulse setting	1. Differential input of 5V 2. Response frequency: 200kHz
A2-		
B2+		
B2-		
Z2+		
Z2-		
AO+	Frequency-divided output	1. Differential output of 5V 2. Frequency-divided output of resolver simulated A1, B1, and Z1, equal to an incremental PG card of 1024 PPR, supporting frequency division of 2N, which can be set through P20.16 or P24.16; Max. output frequency: 200 kHz
AO-		
BO+		
BO-		
ZO+		
ZO-		

The following figure shows the external wiring when EC-PG504-00 is used.

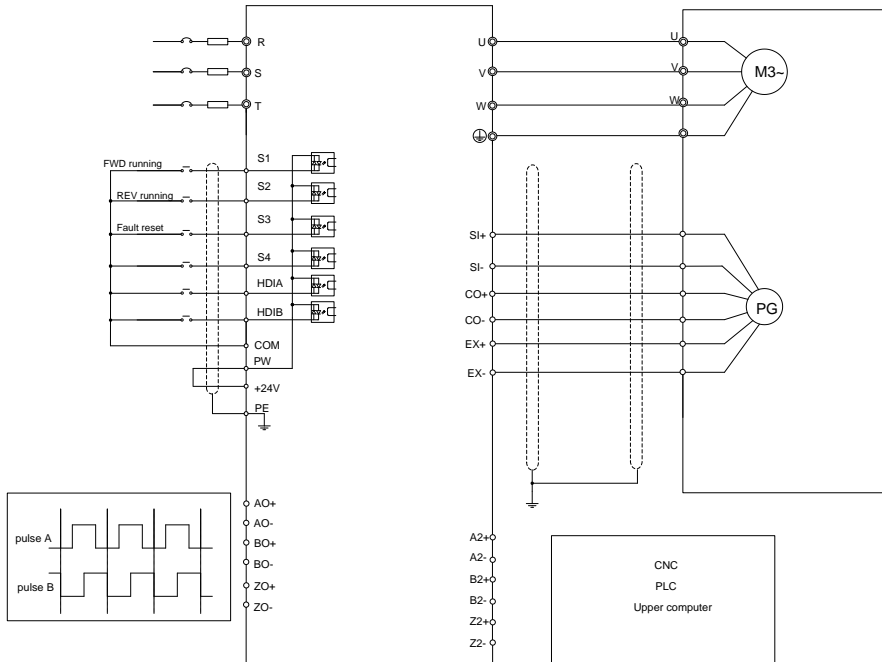

A.6.4 Multi-function incremental PG card (EC-PG505-12)



The terminals are arranged as follows:

The dual in-line package (DIP) switch SW1 is used to set the voltage class (5V or 12V) of the power supply of the encoder. The DIP switch can be operated with an auxiliary tool.

PE	AO+	BO+	ZO+	A1+	B1+	Z1+	A2+	B2+	Z2+	PWR
GND	AO-	BO-	ZO-	A1-	B1-	Z1-	A2-	B2-	Z2-	PGND

Indicator definition:

Indicator	Definition	Function
LED1	Status indicator	This indicator is on when the card is establishing a connection with

Indicator	Definition	Function
		the control board; it blinks periodically after the card is properly connected to the control board (the period is 1s, on for 0.5s, and off for the other 0.5s); and it is off when the card is disconnected from the control board.
LED2	Disconnection indicator	This indicator blinks only when A1 or B1 signal is disconnected during encoder rotating; and it is on in other cases.
LED3	Power indicator	This indicator is on after the control board feeds power to the card.

EC-PG505-12 can be used in combination with multiple types of incremental encoders through different modes of wiring. It is user-friendly, adopting spring terminals.

EC-PG505-12 terminal function description:

Signal	Port	Description
PE	Grounding terminal	Connected to the ground to enhance anti-interference performance.
GND	Ground	Ground of the PCB internal power.
PWR	Encoder power	Voltage: 5V/12V ± 5% Max. output: 150 mA Select the voltage class through SW1 based on the voltage class of the used encoder. (PGND is the isolation power ground.)
PGND		
A1+	Encoder interface	1. Applicable to 5V/12V push-pull encoders 2. Applicable to 5V/12V OC encoders 3. Applicable to 5V differential encoders 4. Response frequency: 200 kHz
A1-		
B1+		
B1-		
Z1+		
Z1-		
A2+	Pulse setting	1. Supportings the same signal types as the encoder signal types 2. Response frequency: 200 kHz
A2-		
B2+		
B2-		
Z2+		
Z2-		
AO+	Frequency-divided output	1. Differential output of 5V 2. Supporting frequency division of 1–255, which can be set through P20.16 or P24.16
AO-		
BO+		
BO-		
ZO+		
ZO-		

The following figure shows the external wiring of the expansion card used in combination with an open collector encoder. A pull-up resistor is configured inside the PG card.

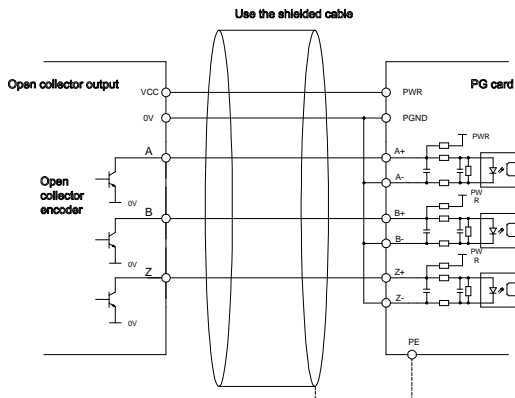
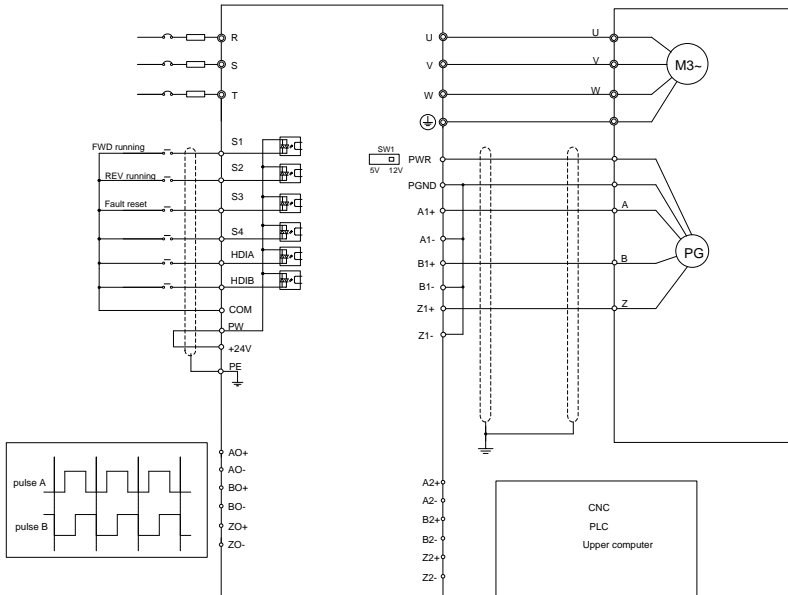

The following figure shows the external wiring when the expansion card is used in combination with a push-pull encoder.

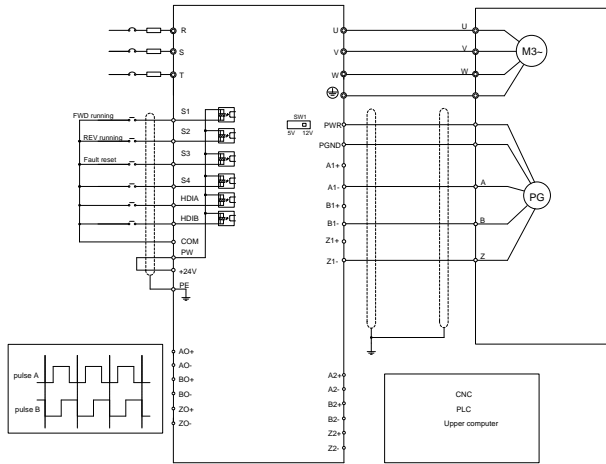

Use the shielded cable

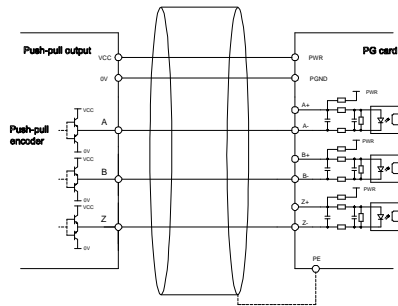

The following figure shows the external wiring when the expansion card is used in combination with a differential encoder.

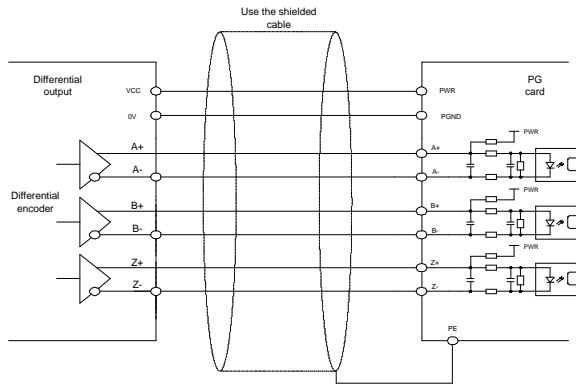
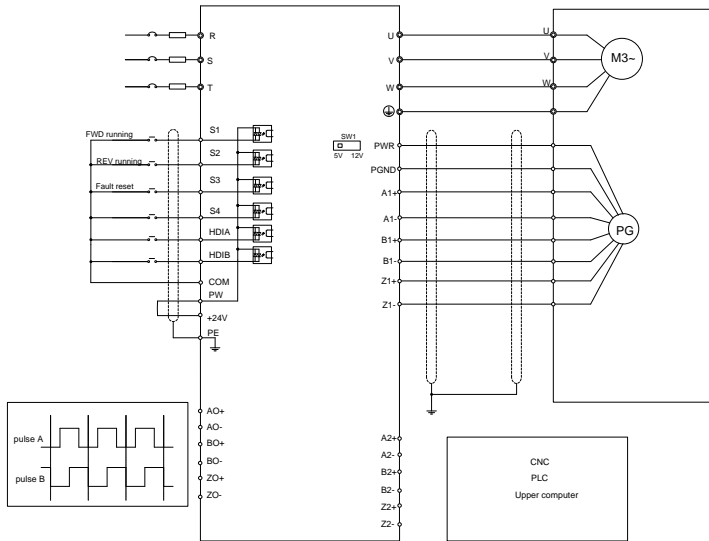

A.6.5 Simplified incremental PG card (EC-PG507-12)



The terminals are arranged as follows:

The dual in-line package (DIP) switch SW1 is used to set the voltage class (5V or 12V) of the power supply of the encoder. The DIP switch can be operated with an auxiliary tool.

PE	A1+	B1+	Z1+	PWR
PGND	A1-	B1-	Z1-	PGND

Indicator definition:

Indicator	Definition	Function
LED1	Status indicator	This indicator is on when the card is establishing a connection with the control board; it blinks periodically after the card is properly connected to the control board (the period is 1s, on for 0.5s, and off for the other 0.5s); and it is off when the card is disconnected from the control board.
LED2	Disconnection indicator	This indicator is off when A1 and B1 of the encoder are disconnected; it is on when the encoder pulses are normal.
LED3	Power indicator	This indicator is on after the control board feeds power to the card.

EC-PG507-12 can work in combination with multiple types of incremental encoders through various external wiring modes, which are similar to the wiring modes of EC-PG505-12.

EC-PG507-12 terminals are described as follows:

Signal	Port	Description
PE	Grounding terminal	Connected to the ground to enhance anti-interference performance.
PWR	Encoder power	Voltage: 5V/12V \pm 5% Max. output: 150 mA Select the voltage class through SW1 based on the voltage class of the used encoder. (PGND is the isolation power ground.)
PGND		
A1+	Encoder interface	<ol style="list-style-type: none"> Supporting push-pull interfaces of 5V/12V Supporting open collector interfaces of 5V/12V Supporting differential interfaces of 5V Response frequency: 400kHz Support the encoder cable length of up to 50m
A1-		
B1+		
B1-		
Z1+		
Z1-		

A.6.6 24V simplified incremental PG card (EC-PG507-24)



The terminals are arranged as follows:

PE	A1+	B1+	Z1+	PWR
PGND	A1-	B1-	Z1-	PGND

Indicator definition:

Indicator	Definition	Function
LED1	Status indicator	This indicator is on when the card is establishing a connection with the control board; it blinks periodically after the card is properly connected to the control board (the period is 1s, on for 0.5s, and off for the other 0.5s); and it is off when the card is disconnected from the control board.
LED2	Disconnection indicator	This indicator is off when A1 and B1 of the encoder are disconnected; it is on when the encoder pulses are normal.
LED3	Power indicator	This indicator is on after the control board feeds power to the card.

EC-PG507-24 can work in combination with multiple types of incremental encoders through various external wiring modes. It uses terminals with the spacing of 5.08mm, easy to use.

EC-PG507-24 terminals are described as follows:

Signal	Port	Description
PE	Grounding terminal	Connected to the ground to enhance anti-interference performance.
PWR	Encoder power	Voltage: 24V ± 5% Max. current: 150 mA (PGND is the isolation power ground.)
PGND		
A1+	Encoder interface	1. Supporting push-pull interfaces of 24V 2. Supporting open collector interfaces of 24V 3. Supporting differential interfaces of 24V 4. Response frequency: 200 kHz 5. Support the encoder cable length of up to 100m
A1-		
B1+		
B1-		
Z1+		
Z1-		

The following figure shows the external wiring of the card when it is used in combination with an open collector encoder. A pull-up resistor is configured in the PG card.

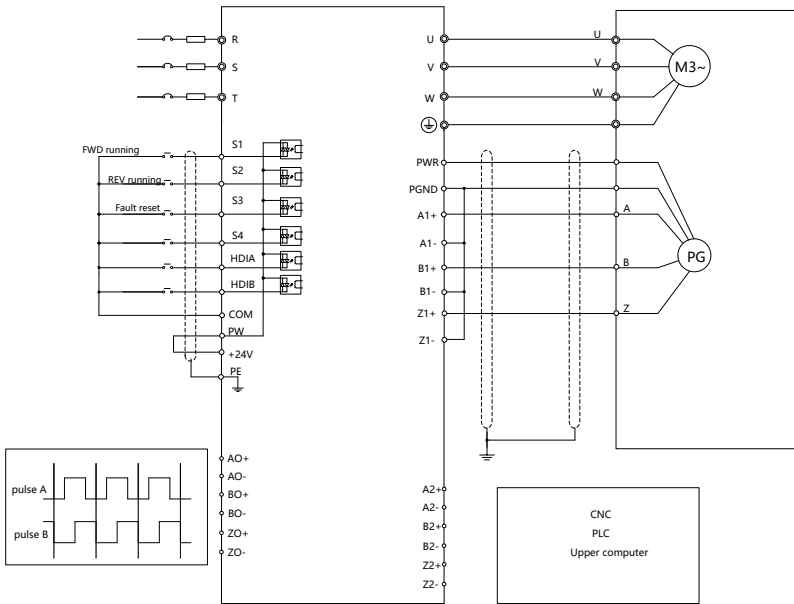

Use shield cable

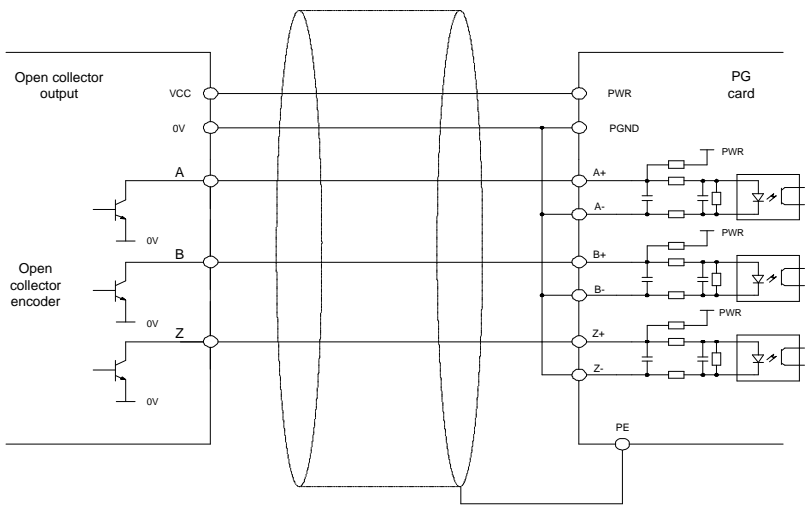

The following figure shows the external wiring when the expansion card is used in combination with a push-pull encoder.

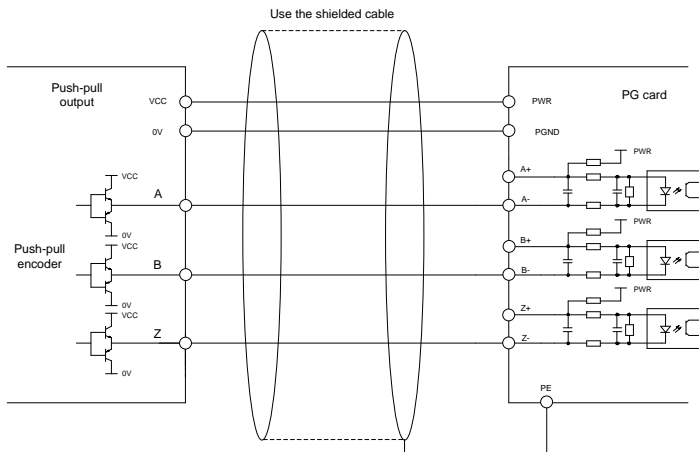
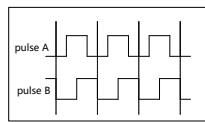
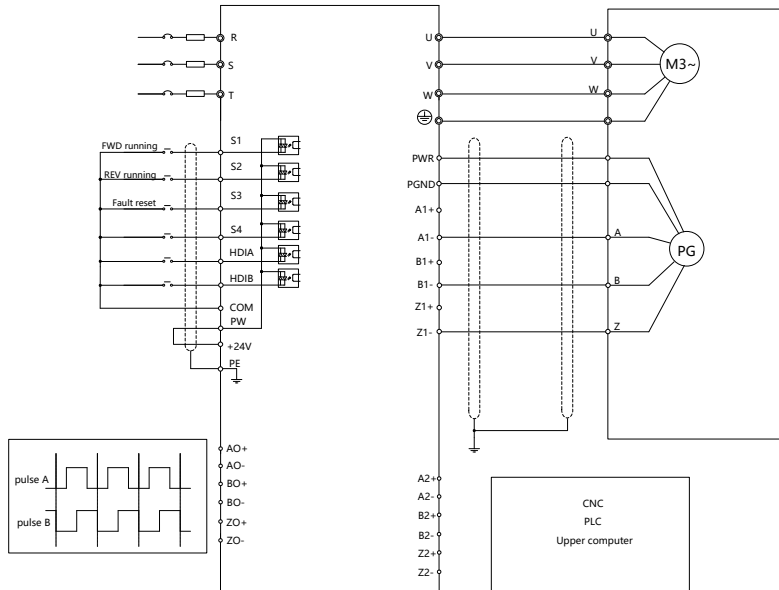

The following figure shows the external wiring when the expansion card is used in combination with a differential encoder.

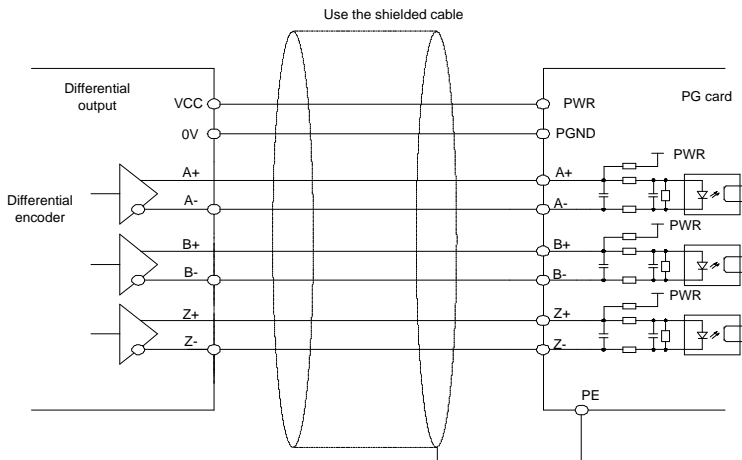
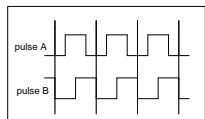
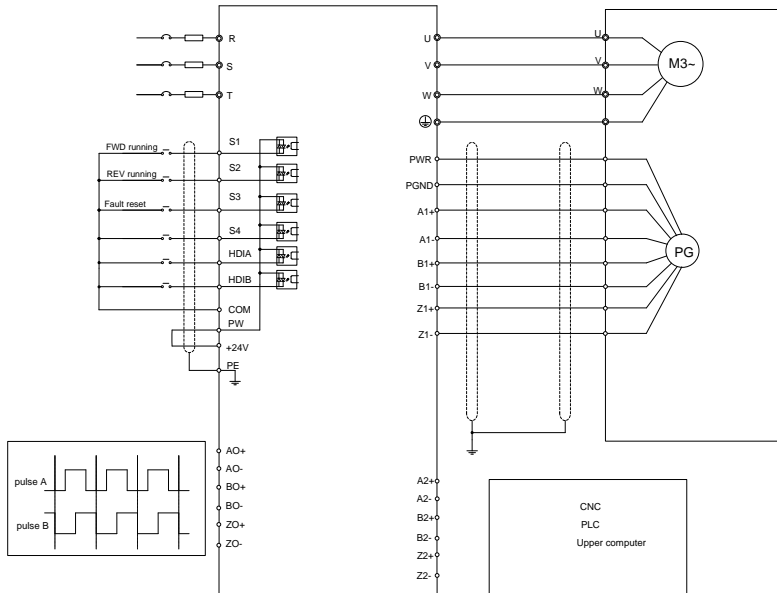

A.7 IoT cards

A.7.1 4G card (EC-IC502-2)



Terminal definition

Terminal	Port	Function
4-pin terminal	485 communication interface	Terminals are 24V, GND, 485+, and 485-.
CN5	Antenna	4G antenna terminal
SIM	SIM card slot	Used to install a SIM card.

Indicator definition

Indicator	Definition	Description
LED1	3.8V power indicator	It is steady on after the card is powered.
LED2	3.8V power indicator	It is steady on after the card is powered.
LED3	4G network indicator	<ul style="list-style-type: none"> Blinking fast (on for 600ms; off for 600ms): No SIM card/SIM PIN/Registering with a network/Failed to register Blinking slowly (on for 75ms; off for 3000ms): Standby Blinking extremely fast (on for 75ms; off for 75ms): Data link established
LED4	Hand shaking indicator	Fast blinking at frequency of 1s: The card connects to the control board properly.
LED5	Run indicator	<ul style="list-style-type: none"> Fast blinking at frequency of 1s: Normal running. Steady on or off: Abnormal running.

A.8 Power supply cards

A.8.1 24V power supply card (EC-PS501-24)



Indicator definition

Indicator	Name	Description
LED1	24V power indicator	Indicator for the external 24V power.
LED2	5V power indicator	Indicator for the 5V power that is provided for the control board after the switch power converts external power.

The 24V power supply card is mainly used to connect to external 24V power to power the control board, avoiding to apply electricity for independent control board commissioning. During wiring, connect to +24V and COM according to the CN2 sign.

Appendix B Technical data

B.1 What this chapter contains

This chapter describes the technical data of the VFD and its compliance to CE and other quality certification systems.

B.2 Derated application

B.2.1 Capacity

Choose a VFD model based on the rated current and power of the motor. To endure the rated power of the motor, the rated output current of the VFD must be larger or equal to the rated current of the motor. The rated power of the VFD must be higher or equal to that of the motor.

Note:

- The maximum allowable shaft power of the motor is limited to 1.5 times the rated power of the motor. If the limit is exceeded, the VFD automatically restricts the torque and current of the motor. This function effectively protects the input shaft against overload.
- The rated capacity is the capacity at the ambient temperature of 40°C.
- You need to check and ensure that the power flowing through the common DC connection in the common DC system does not exceed the rated power of the motor.

B.2.2 Derating

If the ambient temperature on the site where the VFD is installed exceeds 40°C, the altitude exceeds 1000m, or the switching frequency is changed from 4kHz to 8, 12, or 15kHz, the VFD needs to be derated.

B.2.2.1 Derating due to temperature

When the temperature ranges from +40°C to +50°C, the rated output current is derated by 1% for each increased 1°C. For the actual derating, see the following figure.

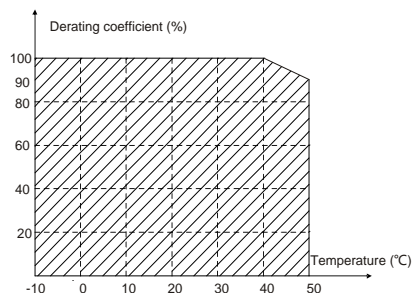

Note: It is not recommended to use the VFD at an environment with the temperature higher than 50°C. If you do, you shall be held accountable for the consequences caused.

B.2.2.2 Derating due to altitude

When the altitude of the site where the VFD is installed is lower than 1000m, the VFD can run at the rated power. When the altitude exceeds 1000m, derate by 1% for every increase of 100m. When the altitude exceeds 3000m, consult the local INVT dealer or local INVT office for details.

B.2.2.3 Derating due to carrier frequency

The power of Goodrive350-19 series VFDs varies according to carrier frequencies. The VFD rated power is defined based on the carrier frequency set in factory. If the carrier frequency exceeds the factory setting, the power of the VFD is derated by 10% for each increased 1 kHz.

B.3 Grid specifications

Grid voltage	AC 3PH 380V(-15%)–440V(+10%) AC 3PH 520V(-15%)–690V(+10%)
Short-circuit capacity	According to the definition in IEC 61439-1, the maximum allowable short-circuit current at the incoming end is 100kA. Therefore, the VFD is applicable to scenarios where the transmitted current in the circuit is no larger than 100 kA when the VFD runs at the maximum rated voltage.
Frequency	50/60 Hz±5%, with a maximum change rate of 20%/s

B.4 Motor connection data

Motor type	Asynchronous induction motor or permanent-magnet synchronous motor
Voltage	0–U ₁ (motor rated voltage), 3PH symmetrical, U _{max} (VFD rated voltage) at the field-weakening point
Short-circuit protection	The motor output short-circuit protection meets the requirements of IEC 61800-5-1.
Frequency	0–400 Hz
Frequency resolution	0.01 Hz
Current	See section 3.6 Product ratings.
Power limit	1.5 times of the rated power of the motor
Field-weakening point	10...400 Hz
Carrier frequency	4, 8, 12, or 15 kHz

B.5 Application standards

The following table describes the standards that VFDs comply with.

EN/ISO 13849-1	Safety of machinery—Safety-related parts of control systems—Part 1: General principles for design
IEC/EN 60204-1	Safety of machinery. Electrical equipment of machines. Part 1: General requirements

IEC/EN 62061	Safety of machinery—Safety-related functional safety of electrical, electronic, and programmable electronic control systems
IEC/EN 61800-3	Adjustable speed electrical power drive systems. Part 3: EMC requirements and specific test methods
IEC/EN 61800-5-1	Adjustable speed electrical power drive systems—Part 5-1: Safety requirements—Electrical, thermal and energy
IEC/EN 61800-5-2	Adjustable speed electrical power drive systems—Part 5-2: Safety requirements—Function
GB/T 30844.1-2014	General-purpose variable-frequency adjustable-speed equipment of 1 kV and lower—Part 1: Technical conditions
GB/T 30844.2-2014	General-purpose variable-frequency adjustable-speed equipment of 1 kV and lower—Part 2: Test methods
GB/T 30844.3-2017	General-purpose variable-frequency adjustable-speed equipment of 1 kV and lower—Part 3: Safety regulations

B.5.1 CE marking

The CE marking on the name plate of a VFD indicates that the VFD is CE-compliant, meeting the regulations of the European low-voltage directive (2014/35/EU) and EMC directive (2014/30/EU).

B.5.2 EMC compliance declaration

European union (EU) stipulates that the electric and electrical devices sold in Europe cannot generate electromagnetic disturbance that exceeds the limits stipulated in related standards, and can work properly in environments with certain electromagnetic interference. The EMC product standard (EN 61800-3) describes the EMC standards and specific test methods for adjustable speed electrical power drive systems. Our products have been compliant with these EMC regulations.

B.6 EMC regulations

The EMC product standard (EN 61800-3) describes the EMC requirements on VFDs.

Application environment categories:

First environment: Civilian environments, including application scenarios where VFDs are directly connected to the civil power supply low-voltage grids without intermediate transformers.

Second environment: All environments except those in Category I.

VFD categories:

C1: Rated voltage lower than 1000 V, applied to environments of Category I.

C2: Rated voltage lower than 1000 V, non-plug, socket, or mobile devices; power drive systems that must be installed and operated by specialized personnel when applied to environments of Category I

Note: The EMC standard IEC/EN 61800-3 no longer restricts the power distribution of VFDs, but it specifies their use, installation, and commissioning. Specialized personnel or organizations must have the necessary skills (including the EMC-related knowledge) for

installing and/or performing commissioning on the electrical drive systems.

C3: Rated voltage lower than 1000 V, applied to environments of Category II. They cannot be applied to environments of Category I.

C4: Rated voltage higher than 1000 V, or rated current higher or equal to 400 A, applied to complex systems in environments of Category II.

B.6.1 VFD category of C2

The induction disturbance limit meets the following stipulations:

1. Select an optional EMC filter according to Appendix D Optional peripheral accessories and install it following the description in the EMC filter manual.
2. Select the motor and control cables according to the description in the manual.
3. Install the VFD according to the description in the manual.



◇ Currently in environments in China, the VFD may generate radio interference, you need to take measures to reduce the interference.

B.6.2 VFD category of C3

The anti-interference performance of the VFD meets the requirements of the second environment in the IEC/EN 61800-3 standard.

The induction disturbance limit meets the following stipulations:

1. Select an optional EMC filter according to Appendix D Optional peripheral accessories and install it following the description in the EMC filter manual.
2. Select the motor and control cables according to the description in the manual.
3. Install the VFD according to the description in the manual.



◇ VFDs of C3 category cannot be applied to civilian low-voltage common grids. When applied to such grids, the VFDs may generate radio frequency electromagnetic interference.

Appendix C Dimension drawings

C.1 What this chapter contains

This chapter describes the dimension drawings of VFD, which use millimeter (mm) as the unit.

C.2 LED keypad

C.2.1 Structure diagram

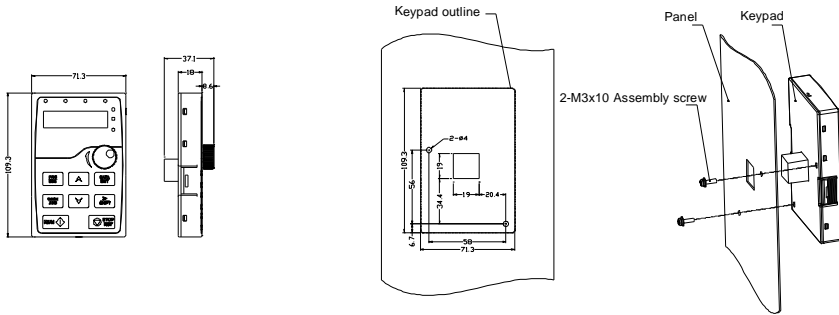

Opening sizes for installing the keypad without a bracket

C.2.2 Keypad mounting bracket

Note: You can directly use M3 threaded screws or an installation bracket to externally connect the keypad to the VFD. The installation bracket is optional for 380V 1.5–30 kW VFD models and 500V 4–18.5 kW VFD models. The installation bracket is a standard part for 380V 37–500 kW VFD models, 500V 22–500 kW VFD models, and all 660V VFD models.

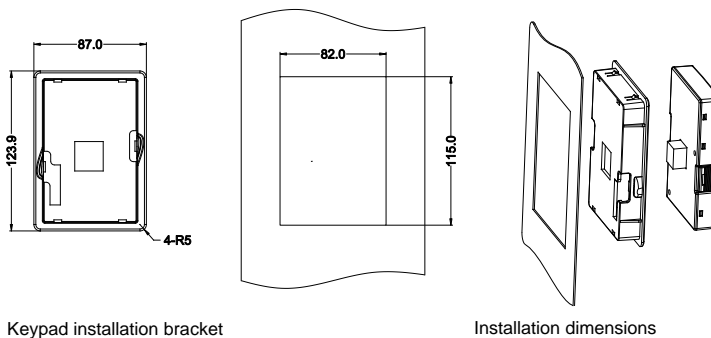
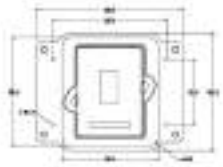
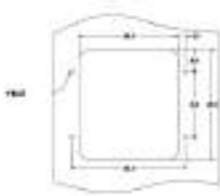

Figure C-1 (Optional) Installation bracket for 380V 1.5–315kW and 660V 22–630kW models



Keypad installation bracket



Installation dimensions



Figure C-2(Standard) Installation bracket for 380V 37–315kW and 660V 22–630kW models

C.3 LCD keypad

C.3.1 Structure diagram

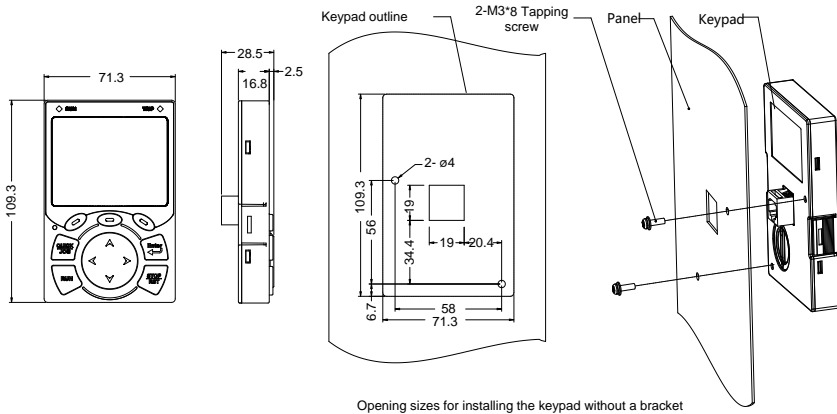

Opening sizes for installing the keypad without a bracket

Figure C-3 Keypad structure

C.3.2 Keypad mounting bracket

Note:

- You can directly use M3 threaded screws or an installation bracket to externally connect the keypad to the VFD.
- For VFDs of 380V 1.5–75 kW, the keypad mounting bracket is an optional part. For those of 380V 90–500 kW and 660V 22–630 kW, you can use optional brackets or use the standard keypad brackets externally.

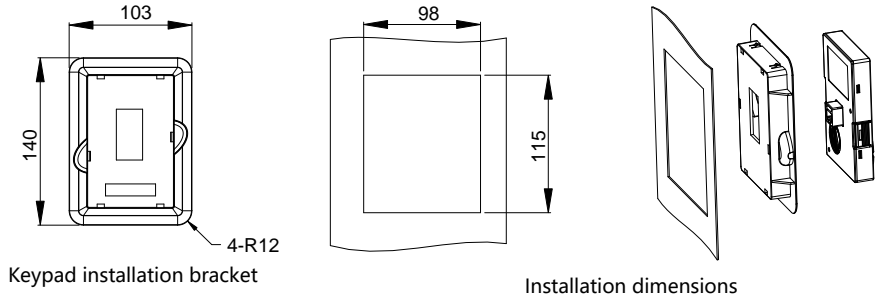

Figure C-4 (Optional) Installation bracket for 380V 1.5–500kW and 660V 22–630kW models

C.4 VFD structure

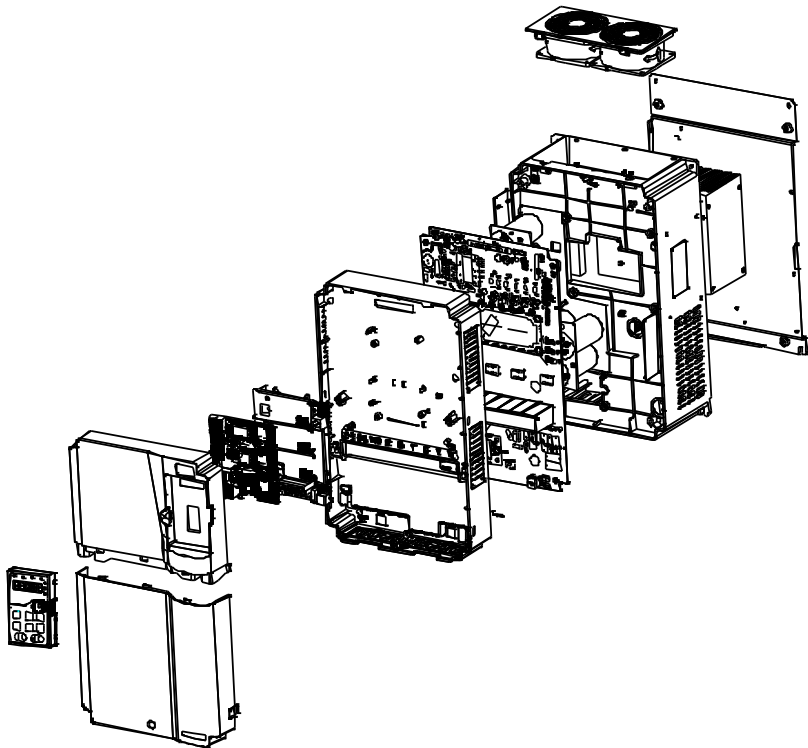

Figure C-5 VFD structure

C.5 Dimensions of AC 3PH 380V (-15%)–440V (+10%)

C.5.1 Wall mounting dimensions

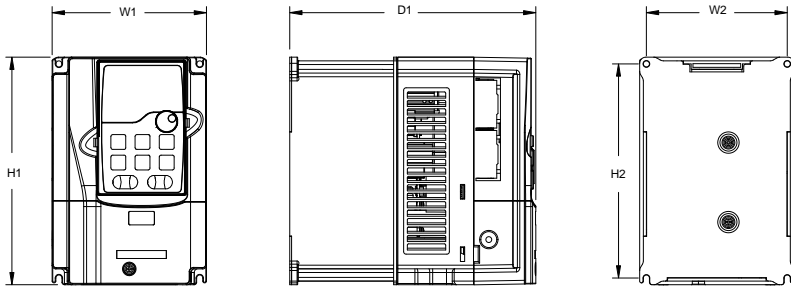

Figure C-6 380V 1.5–37kW VFD wall mounting diagram

VFD model	Outline Dimensions (mm)			Hole distance (mm)		Hole diameter (mm)	Screw	Net weight (kg)	Gross weight (kg)
	W1	H1	D1	W2	H2				
1.5kW–2.2kW	126	186	185	115	175	∅ 5	M4	2	3
4kW–5.5kW	126	186	201	115	175	∅ 5	M4	2.5	3.5
7.5kW	146	256	192	131	243.5	∅ 6	M5	3	4
11kW–15kW	170	320	220	151	303.5	∅ 6	M5	6	7
18.5kW–22kW	200	340.6	208	185	328.6	∅ 6	M5	8.5	10.5
30kW–37kW	250	400	223	230	380	∅ 6	M5	16	17

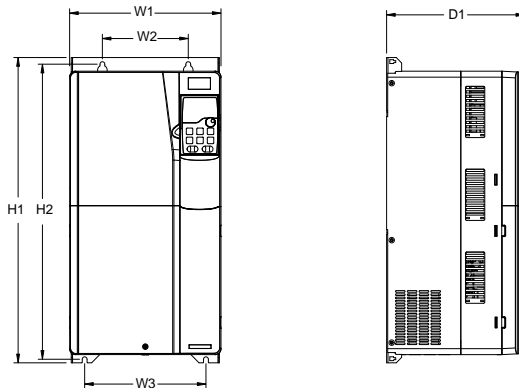

Figure C-7 380V 45–75kW wall mounting diagram

VFD model	Outline Dimensions (mm)			Hole distance (mm)			Hole diameter (mm)	Screw	Net weight (kg)	Gross weight (kg)
	W1	H1	D1	W2	W3	H2				
45kW–75kW	282	560	258	160	226	542	∅ 9	M8	25	29

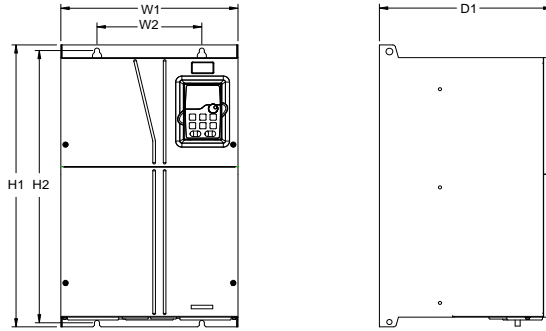

Figure C-8 380V 90-110kW wall mounting diagram

VFD model	Outline Dimensions (mm)			Hole distance (mm)		Hole diameter (mm)	Screw	Net weight (kg)	Gross weight (kg)
	W1	H1	D1	W2	H2				
90kW-110kW	338	554	330	200	535	∅ 10	M8	41	52

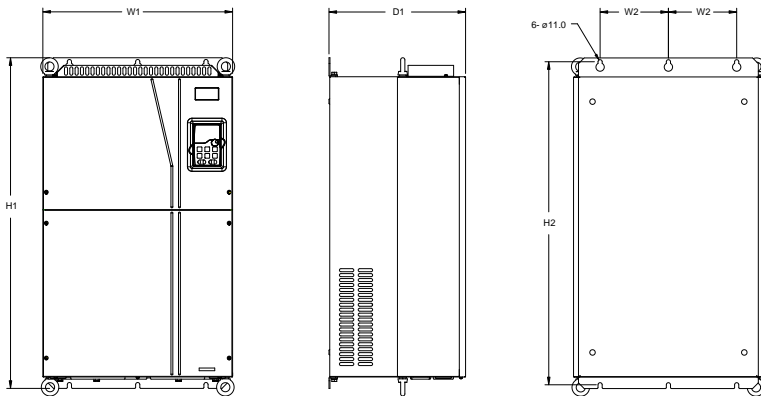

Figure C-9 380V 132-200kW wall mounting diagram

VFD model	Outline Dimensions (mm)			Hole distance (mm)		Hole diameter (mm)	Screw	Net weight (kg)	Gross weight (kg)
	W1	H1	D1	W2	H2				
132kW-200kW	500	870	360	180	850	∅ 11	M10	85	110

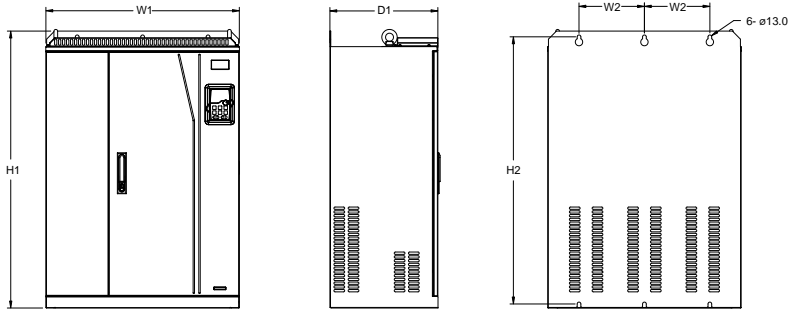

Figure C-10 380V 220-315kW wall mounting diagram

VFD model	Outline Dimensions (mm)			Hole distance (mm)		Hole diameter (mm)	Screw	Net weight (kg)	Gross weight (kg)
	W1	H1	D1	W2	H2				
220kW-315kW	680	960	380	230	926	∅ 13	M12	135	165

C.5.2 Flange installation dimensions

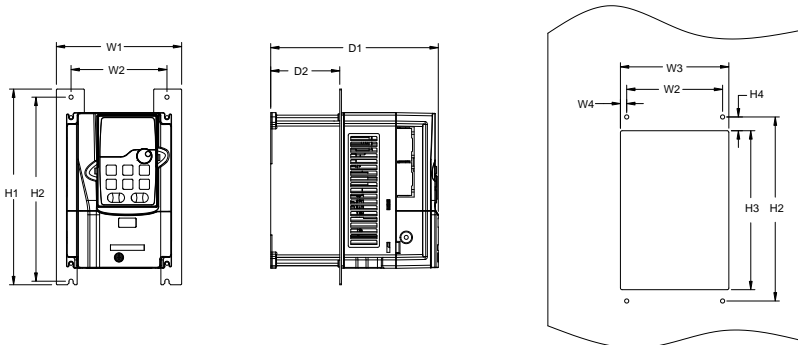

Figure C-11 380V 1.5-75kW flange installation diagram

VFD model	Outline Dimensions (mm)			Mount dimensions (mm)			Hole distance (mm)				Hole diameter (mm)	Screw	Net weight (kg)	Gross weight (kg)
	W1	H1	D1	W2	H2	D2	W3	H3	W4	H4				
1.5-2.2kW	150.2	234	185	115	220	65.5	130	190	7.5	13.5	∅ 5	M4	2	3
4-5.5kW	150.2	234	201	115	220	83	130	190	7.5	13.5	∅ 5	M4	2.5	3.5
7.5kW	170.2	292	192	131	276	84.5	150	260	9.5	6	∅ 6	M5	3	4
11-15kW	191.2	370	220	151	351	113	174	324	11.5	12	∅ 6	M5	6	7
18.5-22kW	266	371	208	250	250	104	224	350.6	13	20.3	∅ 6	M5	8.5	10.5
30-37kW	316	430	223	300	300	118.3	274	410	13	55	∅ 6	M5	16	17
45-75kW	352	580	258	332	400	133.8	306	570	12	80	∅ 9	M8	25	29

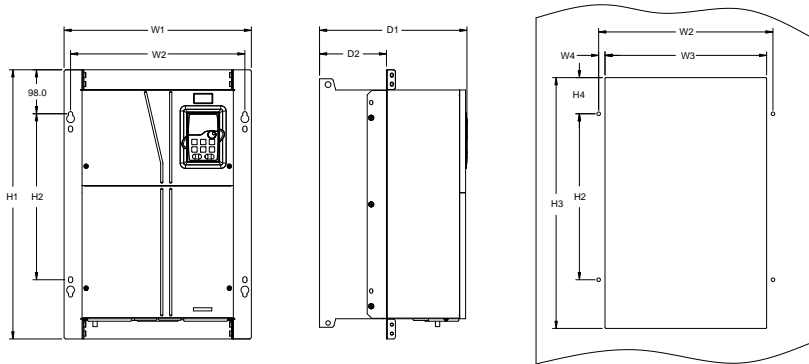

Figure C-12 380V 90-110kW flange installation diagram

VFD model	Outline Dimensions (mm)			Mount dimensions (mm)			Hole distance (mm)			Hole diameter (mm)	Screw	Net weight (kg)	Gross weight (kg)
	W1	H1	D1	W2	H2	D2	H3	W4	H4				
90-110kW	418.5	600	330	389.5	370	149.5	559	14.2	108.5	∅ 10	M8	41	52

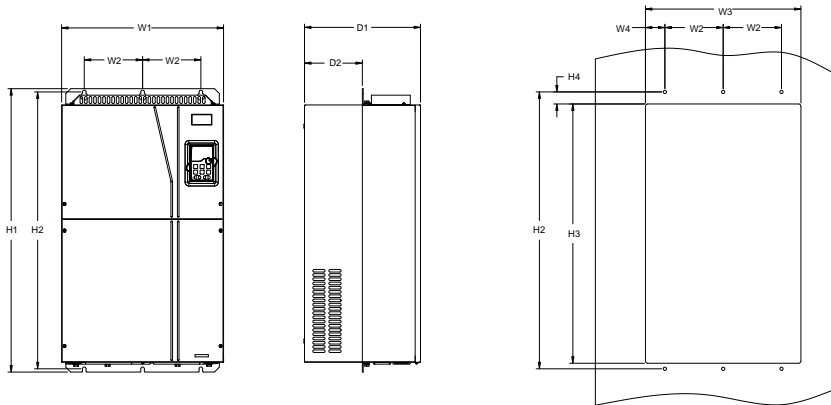

Figure C-13 380V 132-200kW flange installation diagram

VFD model	Outline Dimensions (mm)			Mount dimensions (mm)			Hole distance (mm)				Hole diameter (mm)	Screw	Net weight (kg)	Gross weight (kg)
	W1	H1	D1	W2	H2	D2	W3	H3	W4	H4				
132-200kW	500	870	360	180	850	178.5	480	796	60	37	∅ 11	M10	85	110

C.5.3 Floor installation dimensions

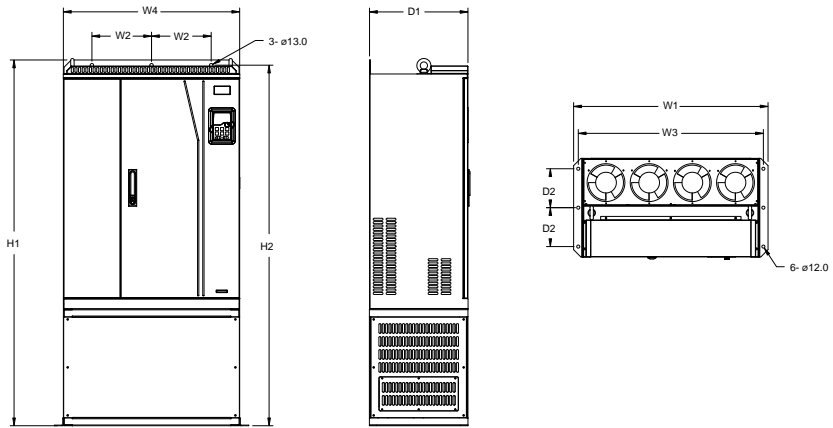

Figure C-14 380V 220–315kW floor installation diagram

VFD model	Outline Dimensions (mm)				Mount dimensions (mm)				Hole diameter (mm)	Screw	Net weight (kg)	Gross weight (kg)
	W1	H1	D1	W4	W2	W3	H2	D2				
220–315kW	750	1410	380	680	230	714	1390	150	ø 13/12	M12/M10	135	165

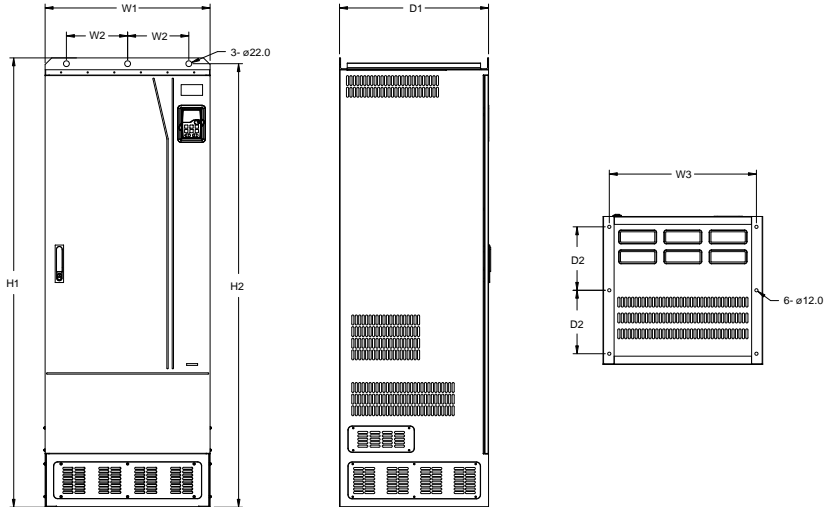

Figure C-15 380V 355–500kW floor installation diagram

VFD model	Outline Dimensions (mm)			Mount dimensions (mm)				Hole diameter (mm)	Screw	Net weight (kg)	Gross weight (kg)
	W1	H1	D1	W2	W3	H2	D2				
355-500kW	620	1700	560	230	572	1678	240	∅ 22/12	M20/M10	350	407

C.6 Dimensions of AC 3PH 520V (-15%)–690V (+10%)

C.6.1 Wall mounting dimensions

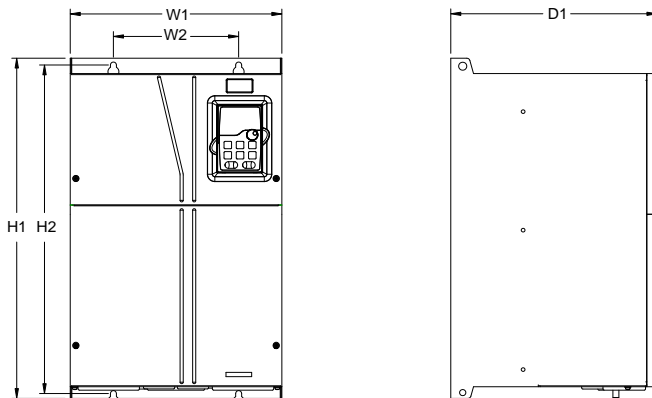

Figure C-16 660V 22-132kW wall mounting diagram

VFD model	Outline Dimensions (mm)			Mount dimensions (mm)		Hole diameter (mm)	Screw	Net weight (kg)	Gross weight (kg)
	W1	H1	D1	W2	H2				
22-45kW	270	555	325	130	540	∅ 7	M6	30	32
55-132kW	325	680	365	200	661	∅ 9.5	M8	47	67

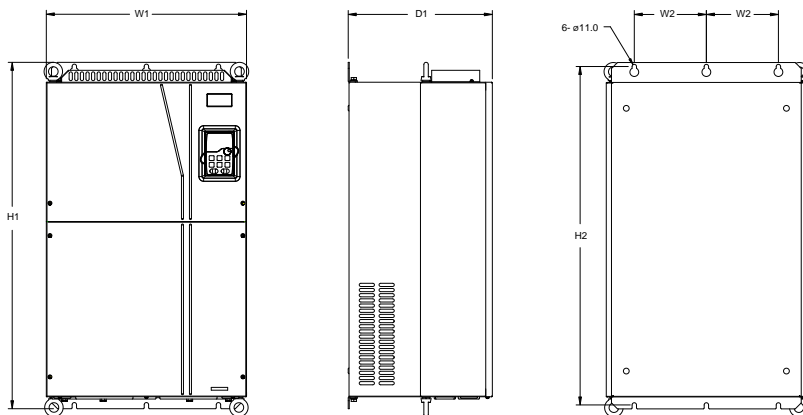

Figure C-17 660V 160-220kW wall mounting diagram

VFD model	Outline Dimensions (mm)			Mount dimensions (mm)		Hole diameter (mm)	Screw	Net weight (kg)	Gross weight (kg)
	W1	H1	D1	W2	H2				
160-220kW	500	870	360	180	850	∅ 11	M10	85	110

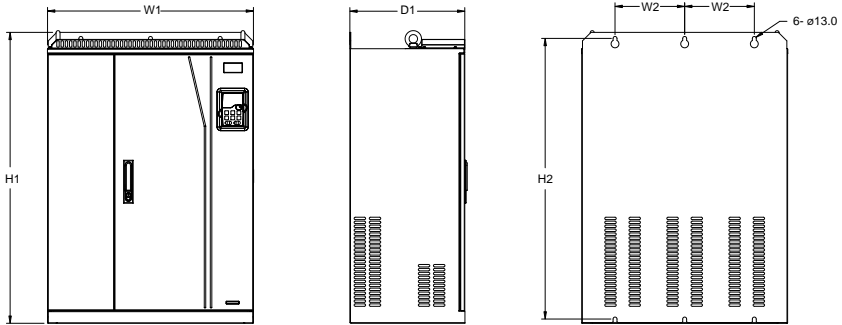

Figure C-18 660V 250-355kW wall mounting diagram

VFD model	Outline Dimensions (mm)			Mount dimensions (mm)		Hole diameter (mm)	Screw	Net weight (kg)	Gross weight (kg)
	W1	H1	D1	W2	H2				
250-355kW	680	960	380	230	926	∅ 13	M12	135	165

C.6.2 Flange installation dimensions

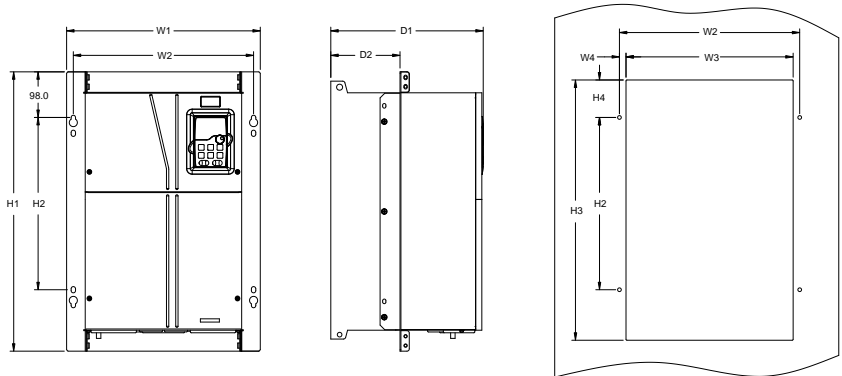

Figure C-19 660V 22-132kW flange installation diagram

VFD model	Outline Dimensions (mm)			Mount dimensions (mm)			Hole distance (mm)				Hole diameter (mm)	Screw	Net weight (kg)	Gross weight (kg)
	W1	H1	D1	W2	H2	D2	W3	H3	W4	H4				
22-45kW	270	555	325	130	540	167	261	516	65.5	17	∅ 7	M6	30	32
55-132kW	325	680	363	200	661	182	317	626	58.5	23	∅ 9.5	M8	47	67

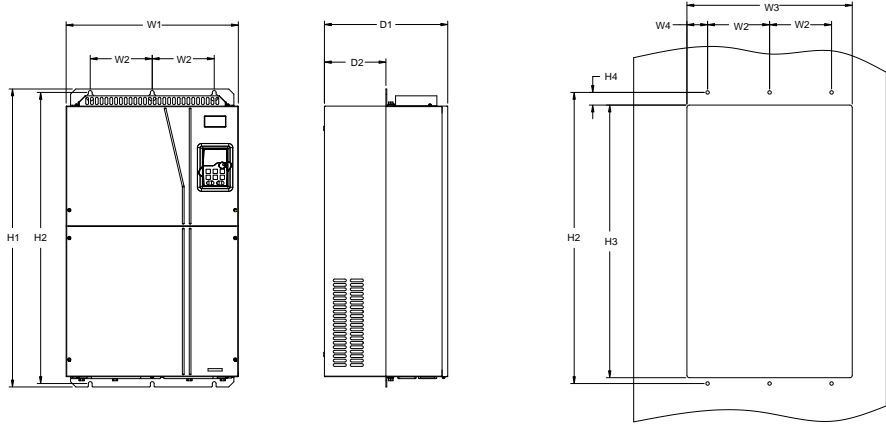

Figure C-20 660V 160-220kW flange installation diagram

VFD model	Outline Dimensions (mm)			Mount dimensions (mm)			Hole distance (mm)				Hole diameter (mm)	Screw	Net weight (kg)	Gross weight (kg)
	W1	H1	D1	W2	H2	D2	W3	H3	W4	H4				
160-220kW	500	870	358	180	850	178.5	480	796	60	37	∅ 11	M10	85	110

C.6.3 Floor installation dimensions

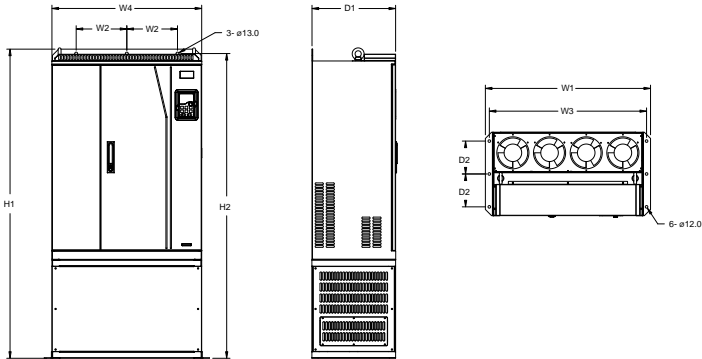

Figure C-21 660V 250-355kW flange installation diagram

VFD model	Outline Dimensions (mm)				Mount dimensions (mm)				Hole diameter (mm)	Screw	Net weight (kg)	Gross weight (kg)
	W1	H1	D1	W4	W2	W3	H2	D2				
250-355kW	750	1410	380	680	230	714	1390	150	∅ 13/12	M12/M10	135	165

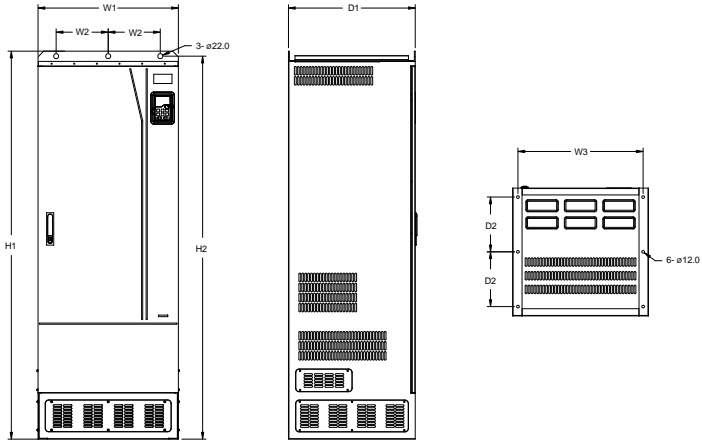

Figure C-22 660V 400-630kW floor installation diagram

VFD model	Outline Dimensions (mm)			Mount dimensions (mm)				Hole diameter (mm)	Screw	Net weight (kg)	Gross weight (kg)
	W1	H1	D1	W2	W3	H2	D2				
400-630kW	620	1700	560	230	572	1678	240	ø 22/12	M20/M10	350	407

Appendix D Optional peripheral accessories

D.1 What this chapter contains

This chapter describes how to select optional accessories of the VFD.





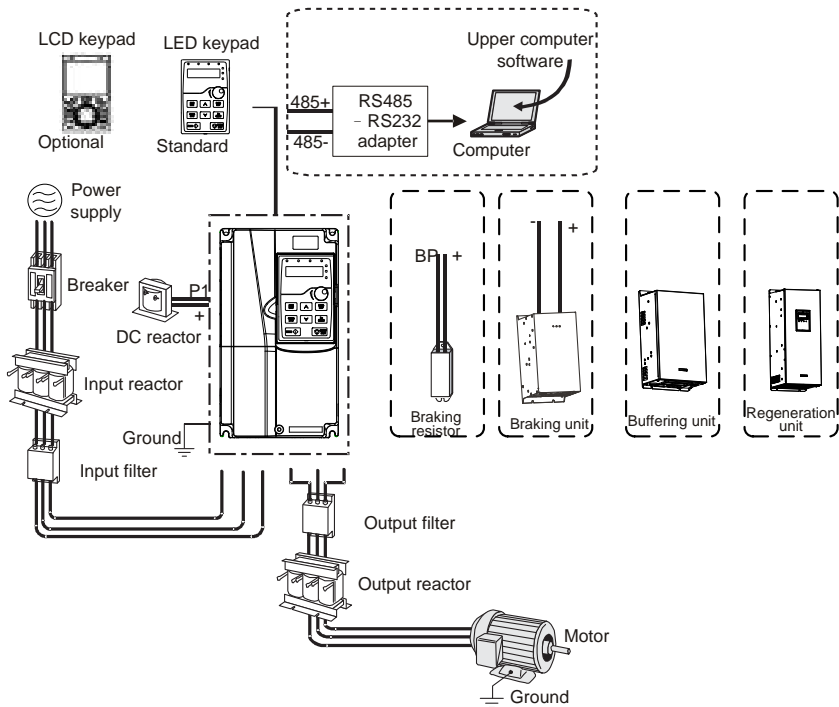

D.2 Wiring of peripheral accessories

The following figure shows the external wiring of the VFD.

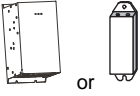

Note:

- The 380V 110kW and lower VFD models are equipped with built-in braking units.
- The 380V 18.5–110kW VFD models are equipped with built-in DC reactors.
- P1 terminals are equipped only for the 380V 132kW and higher models, which enable the VFDs to be directly connected to external DC reactors.
- P1 terminals are equipped for all 660V models, which enable the VFDs to be directly connected to external DC reactors.
- The braking units are INVT DBU series standard braking units. For details, see the DBU operation manual.

Image	Name	Description
	Cable	Accessory for signal transmission.
	Breaker	Device for electric shock prevention and protection against short-to-ground that may cause current leakage and fire. Select residual-current circuit breakers (RCCBs) that are applicable to VFDs and can restrict high-order harmonics, and of which the rated sensitive current for one VFD is larger than 30 mA.
	Input reactor	Accessories used to improve the power factor on the input side of the VFD, and thus restrict high-order harmonic currents.
	DC reactor	Reactors have been built in the 380V 18.5–110kW VFD models as standard configuration. The 380V 132kW and higher VFD models and 660V models can be directly connected to external DC reactors.
	Input filter	Accessory that restricts the electromagnetic interference generated by the VFD and transmitted to the public grid through the power cable. Try to install the input filter near the input terminal side of the VFD.
	Braking unit or braking resistor	Accessories used to consume the regenerative energy of the motor to reduce the DEC time. The 380V 37kW and lower VFD models need only to be configured with braking resistors, the 380V 132kW and higher VFD models and 660V series need to be configured with braking units additionally.
	Output filter	Accessory used to restrict interference generated in the wiring area on the output side of the VFD. Try to install the output filter near the output terminal side of the VFD.
	Output reactor	Accessory used to lengthen the valid transmission distance of the inverter, which effectively restrict the transient high voltage generated during the switch-on and switch-off of the IGBT module of the inverter.

D.3 LCD keypad

You can configure the LCD keypad and LCD keypad installation bracket (which are optional parts) for the VFD.

Name	Description	Order No.
LCD keypad	KEY-LCD01-ZY-350-19	11022-00152
Bracket	GD350 compatible keypad bracket	19005-00149
3m keypad cable	Keypad cable; L=3M(CHV-SE)	37005-00022

D.4 Power supply

See chapter 4 Installation guidelines.

	✧ Ensure that the voltage class of the VFD is consistent with that of the grid.
---	---

D.5 Cable

D.5.1 Power cable

The sizes of the input power cables and motor cables must comply with local regulations.

- ✧ The input power cables and motor cables must be able to carry the corresponding load currents.
- ✧ The maximum temperature margin of the motor cables in continuous operation cannot be lower than 70°C.
- ✧ The conductivity of the PE grounding conductor is the same as that of the phase conductor, that is, the cross-sectional areas are the same. For VFD models of higher than 30kW, the cross sectional area of the PE grounding conductor can be slightly less than the recommended area.
- ✧ For details about the EMC requirements, see Appendix B Technical data.

To meet the EMC requirements stipulated in the CE standards, you must use symmetrical shielded cables as motor cables (as shown in the following figure).

Four-core cables can be used as input cables, but symmetrical shielded cables are recommended. Compared with four-core cables, symmetrical shielded cables can reduce electromagnetic radiation as well as the current and loss of the motor cables.

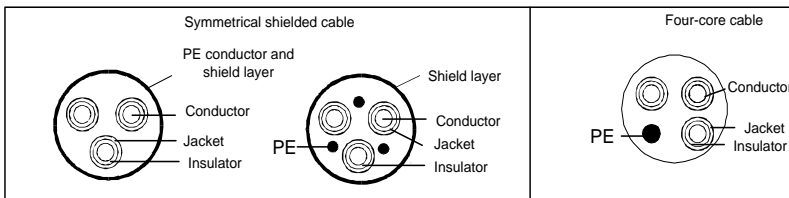

Note: If the conductivity of the shield layer of the motor cables cannot meet the requirements, separate PE conductors must be used.

To protect the conductors, the cross-sectional area of the shielded cables must be the same as that of the phase conductors if the cable and conductor are made of materials of the same type. This reduces grounding resistance, and thus improves impedance continuity.

To effectively restrict the emission and conduction of radio frequency (RF) interference, the conductivity of the shielded cable must at least be 1/10 of the conductivity of the phase conductor. This requirement can be well met by a copper or aluminum shield layer. The following figure shows the minimum requirement on motor cables of a VFD. The cable must consist of a layer of spiral-shaped copper strips. The denser the shield layer is, the more effectively the electromagnetic interference is restricted.

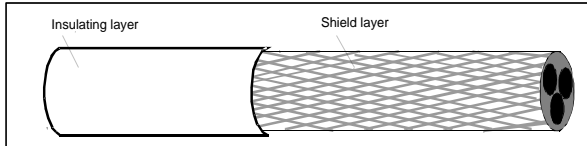

Cross-section of the cable

D.5.2 Control cables

All analog control cables and cables used for frequency input must be shielded cables. Analog signal cables need to be double-shielded twisted-pair cables (as shown in figure a). Use one separate shielded twisted pair for each signal. Do not use the same ground wire for different analog signals.

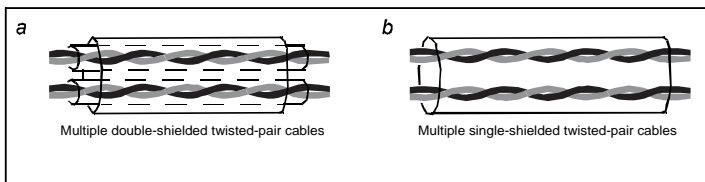

Power cable arrangement

For low-voltage digital signals, double-shielded cables are recommended, but shielded or unshielded twisted pairs (as shown in figure b) also can be used. For frequency signals, however, only shielded cables can be used.

Relay cables need to be those with metal braided shield layers.

Keypads need to be connected by using network cables. In complicated electromagnetic environments, shielded network cables are recommended.

Note: Analog signals and digital signals cannot use the same cables, and their cables must be arranged separately.

Do not perform any voltage endurance or insulation resistance tests, such as high-voltage insulation tests or using a megameter to measure the insulation resistance, on the VFD or its components. Insulation and voltage endurance tests have been performed between the main circuit and chassis of each VFD before delivery. In addition, voltage limiting circuits that can automatically cut off the test voltage are configured inside the VFDs.

Note: Check the insulation conditions of the input power cable of a VFD according to the local

regulations before connecting it.

D.5.3 Recommended cable size

Table D-1 AC 3PH 380V (-15%)–440V(+10%)

VFD model	Recommended cable size (mm ²)		Connectable cable size (mm ²)				Terminal screw	Fastening torque (Nm)
	RST UVW	PE	RST UVW	P1 (+)	PB (+) (-)	PE		
GD350-19-1R5G-4-B	2.5	2.5	2.5-6	2.5-6	2.5-6	2.5-6	M4	1.2-1.5
GD350-19-2R2G-4-B	2.5	2.5	2.5-6	2.5-6	2.5-6	2.5-6	M4	1.2-1.5
GD350-19-004G-4-B	2.5	2.5	2.5-6	2.5-6	2.5-6	2.5-6	M4	1.2-1.5
GD350-19-5R5G-4-B	2.5	2.5	2.5-6	2.5-6	2.5-6	2.5-6	M4	1.2-1.5
GD350-19-7R5G-4-B	4	4	2.5-6	4-6	4-6	2.5-6	M4	1.2-1.5
GD350-19-011G-4-B	6	6	4-10	4-10	4-10	4-10	M5	2.3
GD350-19-015G-4-B	6	6	4-10	4-10	4-10	4-10	M5	2.3
GD350-19-018G-4-B	10	10	10-16	10-16	10-16	10-16	M5	2.3
GD350-19-022G-4-B	16	16	10-16	10-16	10-16	10-16	M5	2.3
GD350-19-030G-4-B	25	16	25-50	25-50	25-50	16-25	M6	2.5
GD350-19-037G-4-B	25	16	25-50	25-50	25-50	16-25	M6	2.5
GD350-19-045G-4-B	35	16	35-70	35-70	35-70	16-35	M8	10
GD350-19-055G-4-B	50	25	35-70	35-70	35-70	16-35	M8	10
GD350-19-075G-4-B	70	35	35-70	35-70	35-70	16-35	M8	10
GD350-19-090G-4-B	95	50	70-120	70-120	70-120	50-70	M12	35
GD350-19-110G-4-B	120	70	70-120	70-120	70-120	50-70	M12	35
GD350-19-132G-4	185	95	95-300	95-300	95-300	95-240	Nuts are used for terminals. You are recommended to use a wrench or sleeve.	
GD350-19-160G-4	240	120	95-300	95-300	95-300	120-240		
GD350-19-185G-4	95*2P	95	95-150	70-150	70-150	35-95		
GD350-19-200G-4	95*2P	120	95*2P -150*2P	95*2P -150*2P	95*2P -150*2P	120-240		
GD350-19-220G-4	150*2P	150	95*2P -150*2P	95*2P -150*2P	95*2P -150*2P	150-240		
GD350-19-250G-4	95*4P	95*2P	95*4P -150*4P	95*4P -150*4P	95*4P -150*4P	95*2P -150*2P		
GD350-19-280G-4	95*4P	95*2P	95*4P -150*4P	95*4P -150*4P	95*4P -150*4P	95*2P -150*2P		
GD350-19-315G-4	95*4P	95*4P	95*4P	95*4P	95*4P	95*2P		

VFD model	Recommended cable size (mm ²)		Connectable cable size (mm ²)				Terminal screw	Fastening torque (Nm)
	RST UVW	PE	RST UVW	P1 (+)	PB (+) (-)	PE		
			-150*4P	-150*4P	-150*4P	-150*2P		
GD350-19-355G-4	95*4P	95*4P	95*4P -150*4P	95*4P -150*4P	95*4P -150*4P	95*2P -150*2P		
GD350-19-400G-4	150*4P	150*2P	95*4P -150*4P	95*4P -150*4P	95*4P -150*4P	95*2P -150*2P		
GD350-19-450G-4	150*4P	150*2P	95*4P -150*4P	95*4P -150*4P	95*4P -150*4P	95*2P -150*2P		
GD350-19-500G-4	150*4P	150*2P	95*4P -150*4P	95*4P -150*4P	95*4P -150*4P	95*2P -150*2P		

Note:

- Cables of the sizes recommended for the main circuit can be used in scenarios where the ambient temperature is lower than 40°C, the wiring distance is shorter than 100m, and the current is the rated current.
- The terminals P1, (+), PB, and (-) are used to connect to DC reactors and braking accessories.

Table D-2 AC 3PH 520V(-15%)–690V(+10%)

VFD model	Recommended cable size (mm ²)		Connectable cable size (mm ²)				Terminal screw	Fastening torque (Nm)
	RST UVW	PE	RST UVW	P1 (+)	PB (+) (-)	PE		
GD350-19-022G-6	10	10	10–16	6–16	6–10	10–16	M8	9–11
GD350-19-030G-6	10	10	10–16	6–16	6–10	10–16	M8	9–11
GD350-19-037G-6	16	16	16–25	16–25	6–10	16–25	M8	9–11
GD350-19-045G-6	16	16	16–25	16–35	16–25	16–25	M8	9–11
GD350-19-055G-6	25	16	16–25	16–35	16–25	16–25	M10	18–23
GD350-19-075G-6	35	16	35–50	25–50	25–50	16–50	M10	18–23
GD350-19-090G-6	35	16	35–50	25–50	25–50	16–50	M10	18–23
GD350-19-110G-6	50	25	50–95	50–95	25–95	25–95	M10	18–23
GD350-19-132G-6	70	35	70–95	70–95	25–95	35–95	M10	18–23
GD350-19-160G-6	95	50	95–150	95–150	25–150	50–150	Nuts are used for terminals. You are recommended to use a	
GD350-19-185G-6	95	50	95–150	95–150	25–150	50–150		
GD350-19-200G-6	120	70	120–300	120–300	35–300	70–240		

VFD model	Recommended cable size (mm ²)		Connectable cable size (mm ²)				Terminal screw	Fastening torque (Nm)
	RST UVW	PE	RST UVW	P1 (+)	PB (+) (-)	PE		
GD350-19-220G-6	185	95	120-300	120-300	35-300	95-240	wrench or sleeve.	
GD350-19-250G-6	185	95	185-300	185-300	35-300	95-240		
GD350-19-280G-6	240	120	240-300	240-300	70-300	120-240		
GD350-19-315G-6	95*2P	120	95*2P -150*2P	95*2P -150*2P	95*2P -150*2P	120-300		
GD350-19-355G-6	95*2P	150	95*2P -150*2P	95*2P -150*2P	95*2P -150*2P	150-300		
GD350-19-400G-6	150*2P	150	150*2P -300*2P	95*2P -150*2P	95*2P -150*2P	150-300		
GD350-19-450G-6	95*4P	95*2P	95*4P -150*4P	95*4P -150*4P	95*4P -150*4P	95*2P -150*2P		
GD350-19-500G-6	95*4P	95*2P	95*4P -150*4P	95*4P -150*4P	95*4P -150*4P	95*2P -150*2P		
GD350-19-560G-6	95*4P	95*4P	95*4P -150*4P	95*4P -150*4P	95*4P -150*4P	95*4P -150*4P		
GD350-19-630G-6	150*4P	150*2P	150*4P -300*4P	150*4P -300*4P	150*4P -300*4P	150*4P -240*4P		

Note:

- Cables of the sizes recommended for the main circuit can be used in scenarios where the ambient temperature is lower than 40°C, the wiring distance is shorter than 100m, and the current is the rated current.
- The terminals P1, (+), PB, and (-) are used to connect to DC reactors and braking accessories.

D.5.4 Cable arrangement

Motor cables must be arranged away from other cables. The motor cables of several inverters can be arranged in parallel. It is recommended that you arrange the motor cables, input power cables, and control cables separately in different trays. The output dU/dt of the inverters may increase electromagnetic interference on other cables. Do not arrange other cables and the motor cables in parallel.

If a control cable and power cable must cross each other, ensure that the angle between them is 90 degrees.

The cable trays must be connected properly and well grounded. Aluminum trays can implement local equipotential. The following figure shows the cable arrangement.

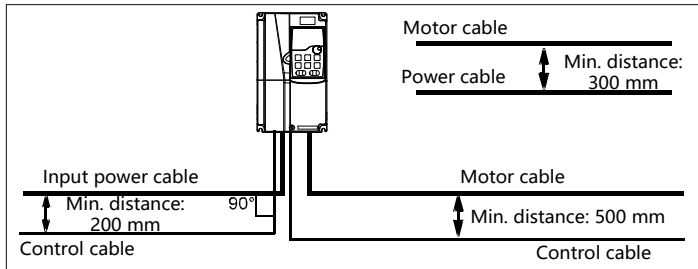

Cable arrangement distances

D.5.5 Insulation inspection

Check the motor and the insulation conditions of the motor cable before running the motor.

1. Ensure that the motor cable is connected to the motor, and then remove the motor cable from the U, V, and W output terminals of the VFD.
2. Use a megameter of 500 V DC to measure the insulation resistance between each phase conductor and the protection grounding conductor. For details about the insulation resistance of the motor, see the description provided by the manufacturer.

Note: The insulation resistance is reduced if it is damp inside the motor. If it may be damp, you need to dry the motor and then measure the insulation resistance again.

D.6 Breaker and electromagnetic contactor

You need to add a fuse to prevent overload. You need to add a fuse to prevent overload.

You need to configure a manually manipulated molded case circuit breaker (MCCB) between the AC power supply and VFD. The breaker must be locked in the open state to facilitate installation and inspection. The capacity of the breaker needs to be 1.5 to 2 times the VFD rated input current.



◇ According to the working principle and structure of breakers, if the manufacturer's regulation is not followed, hot ionized gases may escape from the breaker enclosure when a short-circuit occurs. To ensure safe use, exercise extra caution when installing and placing the breaker. Follow the manufacturer's instructions.

To ensure safety, you can configure an electromagnetic contactor on the input side to control the switch-on and switch-off of the main circuit power, so that the input power supply of the VFD can be effectively cut off when a system fault occurs.

Table D-3 AC 3PH 380V (-15%)–440V(+10%)

VFD model	Fuse (A)	Braker (A)	Contactor rated current (A)
GD350-19-1R5G-4-B	15	16	10
GD350-19-2R2G-4-B	17.4	16	10

VFD model	Fuse (A)	Braker (A)	Contactora rated current (A)
GD350-19-004G-4-B	30	25	16
GD350-19-5R5G-4-B	45	25	16
GD350-19-7R5G-4-B	60	40	25
GD350-19-011G-4-B	78	63	32
GD350-19-015G-4-B	105	63	50
GD350-19-018G-4-B	114	100	63
GD350-19-022G-4-B	138	100	80
GD350-19-030G-4-B	186	125	95
GD350-19-037G-4-B	228	160	120
GD350-19-045G-4-B	270	200	135
GD350-19-055G-4-B	315	200	170
GD350-19-075G-4-B	420	250	230
GD350-19-090G-4-B	480	315	280
GD350-19-110G-4-B	630	400	315
GD350-19-132G-4	720	400	380
GD350-19-160G-4	870	630	450
GD350-19-185G-4	1110	630	580
GD350-19-200G-4	1110	630	580
GD350-19-220G-4	1230	800	630
GD350-19-250G-4	1380	800	700
GD350-19-280G-4	1500	1000	780
GD350-19-315G-4	1740	1200	900
GD350-19-355G-4	1860	1280	960
GD350-19-400G-4	2010	1380	1035
GD350-19-450G-4	2445	1630	1222
GD350-19-500G-4	2505	1720	1290

Note: The accessory specifications described in the preceding table are ideal values. You can select accessories based on the actual market conditions, but try not to use those with lower values.

Table D-4 AC 3PH 520V(-15%)–690V(+10%)

VFD model	Fuse (A)	Braker (A)	Contactora rated current (A)
GD350-19-022G-6	105	63	50
GD350-19-030G-6	105	63	50
GD350-19-037G-6	114	100	63
GD350-19-045G-6	138	100	80
GD350-19-055G-6	186	125	95

VFD model	Fuse (A)	Braker (A)	Contactora rated current (A)
GD350-19-075G-6	270	200	135
GD350-19-090G-6	270	200	135
GD350-19-110G-6	315	200	170
GD350-19-132G-6	420	250	230
GD350-19-160G-6	480	315	280
GD350-19-185G-6	480	315	280
GD350-19-200G-6	630	400	315
GD350-19-220G-6	720	400	380
GD350-19-250G-6	720	400	380
GD350-19-280G-6	870	630	450
GD350-19-315G-6	1110	630	580
GD350-19-355G-6	1110	630	580
GD350-19-400G-6	1230	800	630
GD350-19-450G-6	1470	960	735
GD350-19-500G-6	1500	1000	780
GD350-19-560G-6	1740	1200	900
GD350-19-630G-6	2010	1380	1035

Note: The accessory specifications described in the preceding table are ideal values. You can select accessories based on the actual market conditions, but try not to use those with lower values.

D.7 Reactor

When the voltage of the grid is high, the transient large current that flows into the input power circuit may damage rectifier components. You need to configure an AC reactor on the input side, which can also improve the current adjustment coefficient on the input side.

When the distance between the VFD and motor is longer than 50 m, the parasitic capacitance between the long cable and ground may cause large leakage current, and overcurrent protection of the VFD may be frequently triggered. To prevent this from happening and avoid damage to the motor insulator, compensation must be made by adding an output reactor. When a VFD is used to drive multiple motors, take the total length of the motor cables (that is, sum of the lengths of the motor cables) into account. When the total length is longer than 50 m, an output reactor must be added on the output side of the VFD. If the distance between the VFD and motor is 50 m to 100 m, select the reactor according to the following table. If the distance is longer than 100 m, contact INVT's technical support technicians.

DC reactors can be directly connected to 380V 132kW and higher models and all 660V models. DC

reactors can improve the power factor, avoid damage to bridge rectifiers caused due to large input current of the VFD when large-capacity transformers are connected, and also avoid damage to the rectification circuit caused due to harmonics generated by grid voltage transients or phase-control loads.

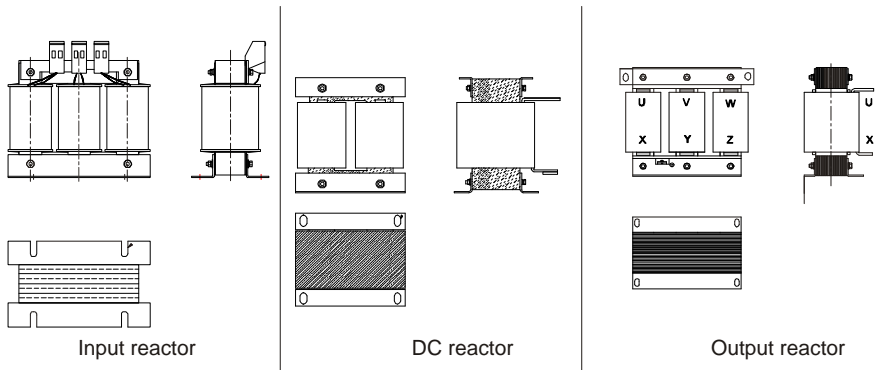

Table D-5 Reactor model selection for AC 3PH 380V(-15%)–440V(+10%)

VFD model	Input reactor	DC reactor	Output reactor
GD350-19-1R5G-4-B	ACL2-1R5-4	/	OCL2-1R5-4
GD350-19-2R2G-4-B	ACL2-2R2-4	/	OCL2-2R2-4
GD350-19-004G-4-B	ACL2-004-4	/	OCL2-004-4
GD350-19-5R5G-4-B	ACL2-5R5-4	/	OCL2-5R5-4
GD350-19-7R5G-4-B	ACL2-7R5-4	/	OCL2-7R5-4
GD350-19-011G-4-B	ACL2-011-4	/	OCL2-011-4
GD350-19-015G-4-B	ACL2-015-4	/	OCL2-015-4
GD350-19-018G-4-B	ACL2-018-4	Built in	OCL2-018-4
GD350-19-022G-4-B	ACL2-022-4	Built in	OCL2-022-4
GD350-19-030G-4-B	ACL2-037-4	Built in	OCL2-037-4
GD350-19-037G-4-B	ACL2-037-4	Built in	OCL2-037-4
GD350-19-045G-4-B	ACL2-045-4	Built in	OCL2-045-4
GD350-19-055G-4-B	ACL2-055-4	Built in	OCL2-055-4
GD350-19-075G-4-B	ACL2-075-4	Built in	OCL2-075-4
GD350-19-090G-4-B	ACL2-110-4	Built in	OCL2-110-4
GD350-19-110G-4-B	ACL2-110-4	Built in	OCL2-110-4
GD350-19-132G-4	ACL2-160-4	DCL2-132-4	OCL2-200-4
GD350-19-160G-4	ACL2-160-4	DCL2-160-4	OCL2-200-4
GD350-19-185G-4	ACL2-200-4	DCL2-200-4	OCL2-200-4
GD350-19-200G-4	ACL2-200-4	DCL2-220-4	OCL2-200-4

VFD model	Input reactor	DC reactor	Output reactor
GD350-19-220G-4	ACL2-280-4	DCL2-280-4	OCL2-280-4
GD350-19-250G-4	ACL2-280-4	DCL2-280-4	OCL2-280-4
GD350-19-280G-4	ACL2-280-4	DCL2-280-4	OCL2-280-4
GD350-19-315G-4	ACL2-350-4	DCL2-315-4	OCL2-350-4
GD350-19-355G-4	Standard	DCL2-400-4	OCL2-350-4
GD350-19-400G-4	Standard	DCL2-400-4	OCL2-400-4
GD350-19-450G-4	Standard	DCL2-500-4	OCL2-500-4
GD350-19-500G-4	Standard	DCL2-500-4	OCL2-500-4

Note:

- The rated input voltage drop of input reactors is 2%±15%.
- The current adjustment coefficient on the input side of the VFD is higher than 90% after a DC reactor is configured.
- The rated output voltage drop of output reactors is 1%±15%.
- The preceding table describes external accessories. You need to specify the ones you choose when purchasing accessories.

Table D-6 Reactor model selection for AC 3PH 520V(-15%)–690V(+10%)

VFD model	Input reactor	DC reactor	Output reactor
GD350-19-022G-6	ACL2-030-6	DCL2-030-6	OCL2-030-6
GD350-19-030G-6	ACL2-030-6	DCL2-030-6	OCL2-030-6
GD350-19-037G-6	ACL2-055-6	DCL2-055-6	OCL2-055-6
GD350-19-045G-6	ACL2-055-6	DCL2-055-6	OCL2-055-6
GD350-19-055G-6	ACL2-055-6	DCL2-055-6	OCL2-055-6
GD350-19-075G-6	ACL2-110-6	DCL2-110-6	OCL2-110-6
GD350-19-090G-6	ACL2-110-6	DCL2-110-6	OCL2-110-6
GD350-19-110G-6	ACL2-110-6	DCL2-110-6	OCL2-110-6
GD350-19-132G-6	ACL2-185-6	DCL2-185-6	OCL2-185-6
GD350-19-160G-6	ACL2-185-6	DCL2-185-6	OCL2-185-6
GD350-19-185G-6	ACL2-185-6	DCL2-185-6	OCL2-185-6
GD350-19-200G-6	ACL2-250-6	DCL2-250-6	OCL2-250-6
GD350-19-220G-6	ACL2-250-6	DCL2-250-6	OCL2-250-6
GD350-19-250G-6	ACL2-250-6	DCL2-250-6	OCL2-250-6
GD350-19-280G-6	ACL2-350-6	DCL2-350-6	OCL2-350-6
GD350-19-315G-6	ACL2-350-6	DCL2-350-6	OCL2-350-6
GD350-19-355G-6	ACL2-350-6	DCL2-350-6	OCL2-350-6
GD350-19-400G-6	Standard	DCL2-400-6	OCL2-400-6
GD350-19-450G-6	Standard	DCL2-560-6	OCL2-560-6

VFD model	Input reactor	DC reactor	Output reactor
GD350-19-500G-6	Standard	DCL2-560-6	OCL2-560-6
GD350-19-560G-6	Standard	DCL2-560-6	OCL2-560-6
GD350-19-630G-6	Standard	DCL2-630-6	OCL2-630-6

Note:

- The rated input voltage drop of input reactors is 2%±15%.
- The current adjustment coefficient on the input side of the VFD is higher than 90% after a DC reactor is configured.
- The rated output voltage drop of output reactors is 1%±15%.
- The preceding table describes external accessories. You need to specify the ones you choose when purchasing accessories.

D.8 Filters

J10 is not connected in factory for the 380V 110kW and lower VFD models. Connect the J10 packaged with the manual if the requirements of level C3 need to be met.

J10 is connected in factory for the 380V 132kW and higher VFD models, all of which meet the requirements of level C3.

Disconnect J10 in the following situations:

- The EMC filter is applicable to the neutral-grounded grid system. If it is used for the IT grid system (that is, the grid system with the neutral point not grounded), disconnect J10.
- If leakage protection occurs during configuration of a residual-current circuit breaker, disconnect J10.

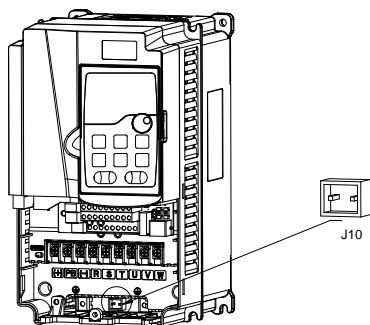

Note: Do not connect C3 filters in IT power systems.

Interference filters on the input side can reduce the VFD interference on the surrounding devices.

Noise filters on the output side can decrease the radio noise caused by the cables between VFDs and

motors and the leakage current of conducting wires.

INVT provides some of the filters for you to choose.

D.8.1 Filter model description

FLT - P 04 045 L - B
A B C D E F

Field	Description
A	FLT: VFD filter series
B	Filter type P: Power input filter L: Output filter
C	Voltage class 04: AC 3PH 380V (-15%)–440V (+10%) 06: AC 3PH 520V (-15%)–690V (+10%)
D	3-digit code indicating the rated current. For example, 015 indicates 15 A.
E	Filter performance L: General H: High-performance
F	Filter application environment A: Environment Category I (IEC61800-3), C1 (EN 61800-3) B: Environment Category I (IEC61800-3), C2 (EN 61800-3) C: Environment Category II (IEC61800-3), C3 (EN 61800-3)

D.8.2 Filter model selection

Table D-7 AC 3PH 380V (-15%)–440V(+10%)

VFD model	Input filter	Output filter
GD350-19-1R5G-4-B	FLT-P04006L-B	FLT-L04006L-B
GD350-19-2R2G-4-B		
GD350-19-004G-4-B	FLT-P04016L-B	FLT-L04016L-B
GD350-19-5R5G-4-B		
GD350-19-7R5G-4-B	FLT-P04032L-B	FLT-L04032L-B
GD350-19-011G-4-B		
GD350-19-015G-4-B	FLT-P04045L-B	FLT-L04045L-B
GD350-19-018G-4-B		
GD350-19-022G-4-B	FLT-P04065L-B	FLT-L04065L-B
GD350-19-030G-4-B		
GD350-19-037G-4-B	FLT-P04100L-B	FLT-L04100L-B
GD350-19-045G-4-B		
GD350-19-055G-4-B	FLT-P04150L-B	FLT-L04150L-B

VFD model	Input filter	Output filter
GD350-19-075G-4-B		
GD350-19-090G-4-B	FLT-P04240L-B	FLT-L04240L-B
GD350-19-110G-4-B		
GD350-19-132G-4		
GD350-19-160G-4	FLT-P04400L-B	FLT-L04400L-B
GD350-19-185G-4		
GD350-19-200G-4		
GD350-19-220G-4	FLT-P04600L-B	FLT-L04600L-B
GD350-19-250G-4		
GD350-19-280G-4		
GD350-19-315G-4	FLT-P04800L-B	FLT-L04800L-B
GD350-19-355G-4		
GD350-19-400G-4		
GD350-19-450G-4	FLT-P041000L-B	FLT-L041000L-B
GD350-19-500G-4		

Note:

- The input EMI meets the C2 requirements after an input filter is configured.
- The preceding table describes external accessories. You need to specify the ones you choose when purchasing accessories.

Table D-8 AC 3PH 520V(-15%)–690V(+10%)

VFD model	Input filter	Output filter
GD350-19-022G-6	FLT-P06050H-B	FLT-L06050H-B
GD350-19-030G-6		
GD350-19-037G-6		
GD350-19-045G-6	FLT-P06100H-B	FLT-L06100H-B
GD350-19-055G-6		
GD350-19-075G-6		
GD350-19-090G-6		
GD350-19-110G-6	FLT-P06200H-B	FLT-L06200H-B
GD350-19-132G-6		
GD350-19-160G-6		
GD350-19-185G-6		
GD350-19-200G-6	FLT-P06300H-B	FLT-L06300H-B
GD350-19-220G-6		

VFD model	Input filter	Output filter
GD350-19-250G-6		
GD350-19-280G-6		
GD350-19-315G-6	FLT-P06400H-B	FLT-L06400H-B
GD350-19-355G-6		
GD350-19-400G-6	FLT-P061000H-B	FLT-L061000H-B
GD350-19-450G-6		
GD350-19-500G-6		
GD350-19-560G-6		
GD350-19-630G-6		
GD350-19-630G-6		



Note:

- The input EMI meets the C2 requirements after an input filter is configured.
- The preceding table describes external accessories. You need to specify the ones you choose when purchasing accessories.

D.9 Braking system

D.9.1 Braking component selection

When the VFD driving a high-inertia load decelerates or needs to decelerate abruptly, the motor runs in the power generation state and transmits the load-carrying energy to the DC circuit of the VFD, causing the bus voltage of the VFD to rise. If the bus voltage exceeds a specific value, the VFD reports an overvoltage fault. To prevent this from happening, you need to configure braking components.

	<ul style="list-style-type: none"> ◇ The design, installation, commissioning, and operation of the device must be performed by trained and qualified professionals. ◇ Follow all the "Warning" instructions during the operation. Otherwise, major physical injuries or property loss may be caused. ◇ Only qualified electricians are allowed to perform the wiring. Otherwise, damage to the VFD or braking components may be caused. ◇ Read the braking resistor or unit instructions carefully before connecting them to the VFD. ◇ Connect braking resistors only to the terminals PB and (+), and braking units only to the terminals (+) and (-). Do not connect them to other terminals. Otherwise, damage to the braking circuit and VFD and fire may be caused.
	<ul style="list-style-type: none"> ◇ Connect the braking components to the VFD according to the wiring diagram. If the wiring is not properly performed, damage to the VFD or other devices may be caused.

The 380V 110kW and lower VFD models are equipped with built-in braking units, and the 380V 132kW and higher VFD models need to be configured with external braking units. Select braking resistors according to the actual situation.

Table D-9 Braking unit models for AC 3PH 380V(-15%)–440V(+10%)

VFD model	Braking unit			Braking resistor			
	BU model	Rated continuous braking current (A)	Max. peak braking current (A)	Resistance applicable to 100% braking torque (Ω)	Min. power for lifting (kW)	Min. power for horizontal moving (kW)	Min. resistance (Ω)
GD350-19-1R5G-4-B	Built-in braking unit	4	4.8	326	≥0.75	≥0.4	170
GD350-19-2R2G-4-B		5.4	6.5	222	≥1.1	≥0.5	130
GD350-19-004G-4-B		8.8	10.5	122	≥2	≥1	80
GD350-19-5R5G-4-B		11.6	14	89	≥2.8	≥1.4	60
GD350-19-7R5G-4-B		14.9	17.8	65	≥3.8	≥1.9	47
GD350-19-011G-4-B		22.6	27	44	≥5.5	≥2.8	31
GD350-19-015G-4-B		30.4	36.5	32	≥7.5	≥3.8	23
GD350-19-018G-4-B		36.8	44.2	27	≥9	≥4.5	19
GD350-19-022G-4-B		41	49.4	22	≥11	≥5.5	17
GD350-19-030G-4-B		54	65	17	≥15	≥7.5	13
GD350-19-037G-4-B		63.6	76.4	13	≥18.5	≥9	11
GD350-19-045G-4-B		80	96	10	≥22.5	≥11	6.4
GD350-19-055G-4-B		100	120	8	≥27.5	≥13	6.4
GD350-19-075G-4-B		110	132	6.5	≥37	≥18	6.4
GD350-19-090G-4-B		160	190	5.4	≥45	≥22	4.4
GD350-19-110G-4-B		220	260	4.5	≥55	≥27	3.2
GD350-19-132G-4		DBU100H-220-4			3.7	≥66	≥33
GD350-19-160G-4	DBU100H-320-4			3.1	≥80	≥40	2.2
GD350-19-185G-4				2.8	≥92	≥46	
GD350-19-200G-4				2.5	≥100	≥50	
GD350-19-220G-4	DBU100H-400-4			2.2	≥110	≥55	1.8
GD350-19-250G-4				2	≥125	≥62	
GD350-19-280G-4	Two DBU100H-320-4			3.6*2	≥70*2	≥35*2	2.2*2
GD350-19-315G-4				3.2*2	≥80*2	≥40*2	
GD350-19-355G-4				2.8*2	≥90*2	≥45*2	
GD350-19-400G-4				2.4*2	≥100*2	≥50*2	
GD350-19-450G-4	Two DBU100H-400-4			2.0*2	≥125*2	≥62*2	1.8*2
GD350-19-500G-4							

Note:

- Select braking resistors according to the resistance and power data provided by our company, but the resistance cannot be less than the min. allowable resistance in the table. Otherwise, braking units may be damaged. In addition to the motor electricity generation power, braking resistors are related to inertia, DEC time, and potential energy, that is, greater inertia, shorter DEC time, and more frequent braking require braking resistors with higher power and smaller resistance.
- When grid voltages are different, you can adjust energy consumption braking threshold voltage. For example, if the threshold voltage needs to be increased, you need to increase the braking resistance.
- The recommended min. power of a braking resistor indicates the rated power of the resistor that can run in a long period of time in nature cooling condition. If air cooling fans are used, the braking resistance can be decreased slightly.
- When using an external braking unit, set the brake voltage class of the braking unit properly by referring to the manual of the dynamic braking unit. If the voltage class is set incorrectly, the VFD may not run properly.
- In hoisting applications, the resistor resistance needs to be less than the braking resistance applicable to 100% torque but greater than the min. resistance.

	✧ Do not use braking resistors whose resistance is lower than the specified minimum resistance. The VFD does not provide protection against overcurrent caused by resistors with low resistance.
---	--

The 660V VFD models need to be configured with external braking units. Select braking resistors according to the specific requirements (such as the braking torque and braking usage) on site.

Table D-10 Braking unit models for AC 3PH 520V(-15%)–690V(+10%)

VFD model	Braking unit model	Resistance applicable to 100% braking torque (Ω)	Min. power for lifting (kW)	Min. power for horizontal moving (kW)	Min. resistance (Ω)
GD350-19-022G-6	DBU100H-110-6	55	11	5.5	10
GD350-19-030G-6		40.3	15	7.5	
GD350-19-037G-6		32.7	18.5	9	
GD350-19-045G-6		26.9	23	11.5	
GD350-19-055G-6		22	27.5	13.5	
GD350-19-075G-6		16.1	37.5	19	
GD350-19-090G-6		13.4	45	22	
GD350-19-110G-6		11	55	27.5	
GD350-19-132G-6	DBU100H-160-6	9.2	66	33	6.9

VFD model	Braking unit model	Resistance applicable to 100% braking torque (Ω)	Min. power for lifting (kW)	Min. power for horizontal moving (kW)	Min. resistance (Ω)	
GD350-19-160G-6		7.6	80	40		
GD350-19-185G-6	DBU100H-220-6	6.5	93	46	5	
GD350-19-200G-6		6.1	100	50		
GD350-19-220G-6		5.5	110	55		
GD350-19-250G-6	DBU100H-320-6	4.8	125	62	3.4	
GD350-19-280G-6		4.3	140	70		
GD350-19-315G-6		3.8	158	78		
GD350-19-355G-6	DBU100H-400-6	3.5	178	89	2.8	
GD350-19-400G-6		3	200	100		
GD350-19-450G-6	Two DBU100H-320-6	4.8*2	125*2	63*2	3.4*2	
GD350-19-500G-6						
GD350-19-560G-6			4.3*2	140*2		70*2
GD350-19-630G-6			3.8*2	315*2		158*2

Note:

- Select braking resistors according to the resistance and power data provided by our company, but the resistance cannot be less than the min. allowable resistance in the table. Otherwise, braking units may be damaged. In addition to the motor electricity generation power, braking resistors are related to inertia, DEC time, and potential energy, that is, greater inertia, shorter DEC time, and more frequent braking require braking resistors with higher power and smaller resistance.
- When grid voltages are different, you can adjust energy consumption braking threshold voltage. For example, if the threshold voltage needs to be increased, increase the braking resistance.
- The recommended min. power of a braking resistor indicates the rated power of the resistor that can run in a long period of time in nature cooling condition. If air cooling fans are used, the braking resistance can be decreased slightly.
- When using an external braking unit, set the brake voltage class of the braking unit properly by referring to the manual of the dynamic braking unit. If the voltage class is set incorrectly, the VFD may not run properly.
- In hoisting applications, the resistor resistance needs to be less than the braking resistance applicable to 100% torque but greater than the min. resistance.

	◇ Do not use braking resistors whose resistance is lower than the specified minimum resistance. The VFD does not provide protection against overcurrent caused by resistors with low resistance.
---	--

D.9.2 Braking resistor cable selection

Braking resistor cables should be shielded cables.

D.9.3 Braking resistor installation

All resistors need to be installed in places with good cooling conditions.

	<ul style="list-style-type: none"> ✧ The materials near the braking resistor or braking unit must be flame resistant, since the surface temperature of the resistor is high and air flowing from the resistor is of hundreds of degrees Celsius. Prevent any materials from coming into contact with the resistor.
---	---

Braking resistor installation

	<ul style="list-style-type: none"> ✧ The 380V 110kW and lower VFD models need only external braking resistors. ✧ PB and (+) are the terminals for connecting braking resistors.
---	---

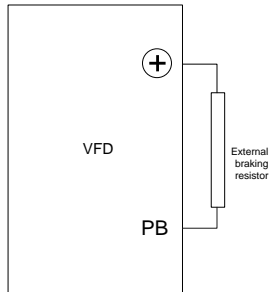

Braking unit installation

	<ul style="list-style-type: none"> ✧ All 660V VFD models need external braking units. ✧ (+) and (-) are the terminals for connecting braking units. ✧ The connection cables between the (+) and (-) terminals of a VFD and those of a braking unit must be shorter than 5m, and the connection cables between the BR1 and BR2 terminals of a braking unit and the two ends of a braking resistor must be shorter than 10m.
--	---

The following figure shows the connection of one VFD to a dynamic braking unit.

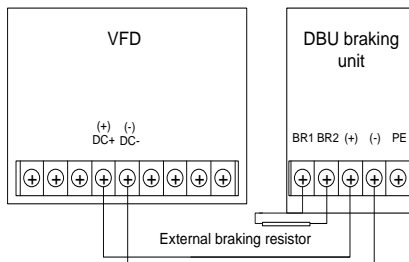

D.10 Regenerative feedback unit

D.10.1 Installation wiring for regenerative feedback unit

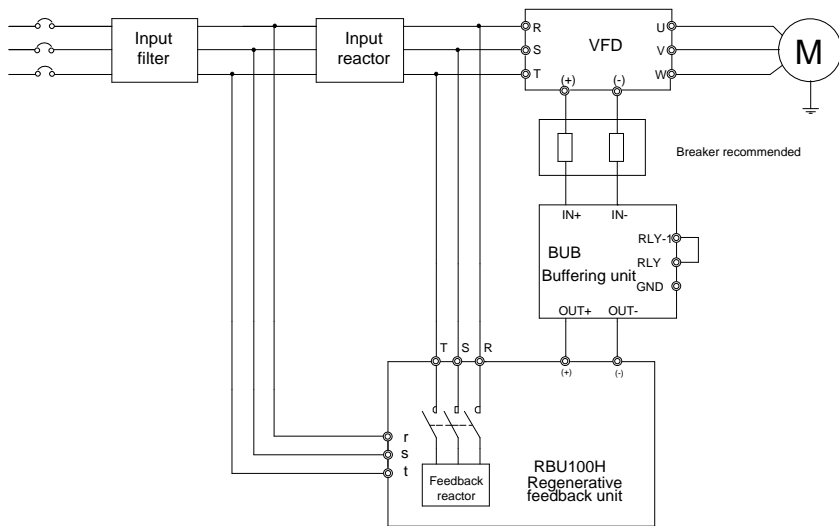

Note: For how to select input filter, input reactor, and feedback reactor models, see the RBU100H regenerative feedback unit operation manual.

D.10.2 Regenerative feedback unit model selection

The following lists the mapping between the 380V VFD models, buffering unit models, and regenerative feedback unit models.

VFD model	Buffering unit	Regenerative feedback unit
GD350-19-022G-4-B	BUB-110-4	RBU100H-022-4
GD350-19-030G-4-B		RBU100H-030-4
GD350-19-037G-4-B		RBU100H-045-4
GD350-19-045G-4-B		RBU100H-045-4
GD350-19-055G-4-B		RBU100H-055-4
GD350-19-075G-4-B		RBU100H-090-4
GD350-19-090G-4-B		RBU100H-090-4
GD350-19-110G-4-B	BUB-250-4	RBU100H-110-4
GD350-19-132G-4		RBU100H-132-4
GD350-19-160G-4		RBU100H-160-4
GD350-19-185G-4		RBU100H-200-4
GD350-19-200G-4	Two	RBU100H-200-4
GD350-19-220G-4	BUB-250-4	RBU100H-250-4

VFD model	Buffering unit	Regenerative feedback unit
GD350-19-250G-4		RBU100H-250-4
GD350-19-280G-4		Two RBU100H-160-4
GD350-19-315G-4		Two RBU100H-160-4
GD350-19-355G-4		Two RBU100H-200-4
GD350-19-400G-4	Three BUB-250-4	Two RBU100H-200-4
GD350-19-450G-4		Two RBU100H-250-4
GD350-19-500G-4		Two RBU100H-250-4

The following lists the mapping between the 660V VFD models, buffering unit models, and regenerative feedback unit models.

VFD model	Buffering unit	Regenerative feedback unit
GD350-19-022G-6	BUB-160-6	RBU100H-055-6
GD350-19-030G-6		RBU100H-055-6
GD350-19-037G-6		RBU100H-055-6
GD350-19-045G-6		RBU100H-055-6
GD350-19-055G-6		RBU100H-055-6
GD350-19-075G-6		RBU100H-090-6
GD350-19-090G-6		RBU100H-090-6
GD350-19-110G-6		RBU100H-160-6
GD350-19-132G-6		RBU100H-160-6
GD350-19-160G-6		RBU100H-160-6
GD350-19-185G-6	BUB-400-6	RBU100H-200-6
GD350-19-200G-6		RBU100H-200-6
GD350-19-220G-6		RBU100H-315-6
GD350-19-250G-6		RBU100H-315-6
GD350-19-280G-6		RBU100H-315-6
GD350-19-315G-6		RBU100H-315-6
GD350-19-355G-6		RBU100H-400-6
GD350-19-400G-6	Two BUB-400-6	RBU100H-400-6
GD350-19-450G-6		Two RBU100H-315-6
GD350-19-500G-6		Two RBU100H-315-6
GD350-19-560G-6		Two RBU100H-315-6
GD350-19-630G-6		Two RBU100H-315-6

Note: For details about how to use buffering units and regenerative feedback units, see the **BUB series buffering unit operation manual** and **RBU100H regenerative feedback unit operation manual**.

Appendix E STO function description

Reference standards: IEC 61508-1, IEC 61508-2, IEC 61508-3, IEC 61508-4, IEC 62061, ISO 13849-1, and IEC 61800-5-2.

You can enable the safe torque off (STO) function to prevent unexpected startups when the main power supply of the drive is not switched off. The STO function switches off the drive output by turning off the drive signals to prevent unexpected startups of the motor (see the following figure). After the STO function is enabled, you can perform some-time operations (such as non-electrical cleaning in the lathe industry) and maintain the non-electrical components of the device without switching off the drive.

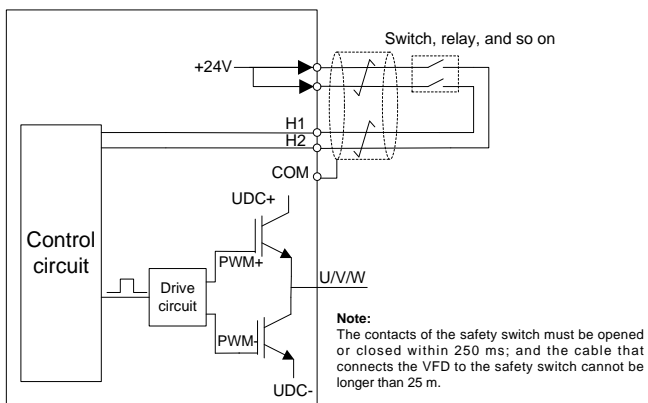

E.1 STO function logic table

The following table describes the input states and corresponding faults of the STO function.

STO input state	Corresponding fault
H1 and H2 opened simultaneously	The STO function is triggered, and the drive stops running. Fault code: 40: Safe torque off (STO)
H1 and H2 closed simultaneously	The STOP function is not triggered, and the drive runs properly.
One of H1 and H2 opened, and the other closed	The STL1, STL2, or STL3 fault occurs. Fault code: 41: Channel H1 exception (STL1) 42: Channel H2 exception (STL2) 43: Channel H1 and H2 exceptions (STL3)

E.2 STO channel delay description

The following table describes the trigger and indication delay of the STO channels.

STO mode	STO trigger delay ¹ and indication delay ²
STO fault: STL1	Trigger delay < 10ms Indication delay < 280ms
STO fault: STL2	Trigger delay < 10ms Indication delay < 280ms
STO fault: STL3	Trigger delay < 10ms Indication delay < 280ms
STO fault: STO	Trigger delay < 10ms Indication delay < 100ms

1. STO trigger delay: Time interval between trigger the STO function and switching off the drive output
2. STO indication delay: Time interval between trigger the STO function and STO output state indication

E.3 STO function installation checklist

Before installing the STO, check the items described in the following table to ensure that the STO function can be properly used.

	Item
<input type="checkbox"/>	Ensure that the drive can be run or stopped randomly during commissioning.
<input type="checkbox"/>	Stop the drive (if it is running), disconnect the input power supply, and isolate the drive from the power cable through the switch.
<input type="checkbox"/>	Check the STO circuit connection according to the circuit diagram.
<input type="checkbox"/>	Check whether the shielding layer of the STO input cable is connected to the +24 V reference ground COM.
<input type="checkbox"/>	Connect the power supply.
<input type="checkbox"/>	Test the STO function as follows after the motor stops running: <ul style="list-style-type: none"> ✧ If the drive is running, send a stop command to it and wait until the shaft of the motor stops rotating. ✧ Activate the STO circuit and send a start command to the drive. Ensure that the motor does not start. ✧ Deactivate the STO circuit.
<input type="checkbox"/>	Restart the drive, and check whether the motor is running properly.
<input type="checkbox"/>	Test the STO function as follows when the motor is running: <ul style="list-style-type: none"> ✧ Start the drive. Ensure that the motor is running properly. ✧ Activate the STO circuit. ✧ The drive reports an STO fault. Ensure that the motor coasts to stop rotating. ✧ Deactivate the STO circuit.
<input type="checkbox"/>	Restart the drive, and check whether the motor is running properly.

Appendix F Further information

F.1 Product and service queries

If you have any queries about the product, contact the local INVT office. Please provide the model and serial number of the product you query about. You can visit www.invt.com to find a list of INVT offices.

F.2 Feedback on INVT VFD manuals

Your comments on our manuals are welcome. Visit www.invt.com, directly contact online service personnel or choose **Contact Us** to obtain contact information.

F.3 Documents on the Internet

You can find manuals and other product documents in the PDF format on the Internet. Visit www.invt.com and choose **Support > Download**.



Service line: 86-755-23535967 E-mail: overseas@invt.com.cn Website: www.invt.com

The products are owned by **Shenzhen INVT Electric Co.,Ltd.**

Two companies are commissioned to manufacture: (For product code, refer to the 2nd/3rd place of S/N on the name plate.)

Shenzhen INVT Electric Co., Ltd. (origin code: 01)
Address: INVT Guangming Technology Building, Songbai Road,
Matian, Guangming District, Shenzhen, China

INVT Power Electronics (Suzhou) Co., Ltd. (origin code: 06)
Address: 1# Kunlun Mountain Road, Science&Technology Town,
Gaixin District, Suzhou, Jiangsu, China

- Industrial Automation:** ■ HMI ■ PLC ■ VFD ■ Servo System
 ■ Elevator Intelligent Control System ■ Rail Transit Traction System
- Energy & Power:** ■ UPS ■ DCIM ■ Solar Inverter ■ SVG
 ■ New Energy Vehicle Powertrain System ■ New Energy Vehicle Charging System
 ■ New Energy Vehicle Motor



6 6 0 0 1 - 0 0 6 6 3

Copyright© INVT.

Manual information may be subject to change without prior notice.

202203 (V1.2)